

5V, Dual Trip Point Temperature Sensors

Features:

- User Programmable Hysteresis and Temperature Set Point
- Easily Programs with 2 External Resistors
- Wide Temperature Detection Range:
 - 0°C to 70°C: (TC620/TC621CCX)
 - 40°C to +125°C: (TC620/TC621CVX)
 - 40°C to +85°C: (TC620/TC621CEX)
 - 55°C to +125°C: (TC620/TC621CMX)
- Onboard Temperature Sensing Applications (TC620X)
- External NTC Thermistor for Remote Sensing Applications (TC621X)
- Available in 8-Pin PDIP and SOIC Packages

Applications:

- Power Supply Over Temperature Detection
- Consumer Equipment
- Temperature Regulators
- CPU Thermal Protection

Device Selection Table

Part Number	Package	Temperature Range
TC620X*COA	8-Pin SOIC	0°C to +70°C
TC620X*CPA	8-Pin PDIP	0°C to +70°C
TC620X*EOA	8-Pin SOIC	-40°C to +85°C
TC620X*EPA	8-Pin PDIP	-40°C to +85°C
TC620C*VOA	8-Pin SOIC	-40°C to +125°C
TC621X*COA	8-Pin SOIC	0°C to +70°C
TC621X*CPA	8-Pin PDIP	0°C to +70°C
TC621X*EOA	8-Pin SOIC	-40°C to +85°C
TC621X*EPA	8-Pin PDIP	-40°C to +85°C

Note: *The part code will be C or H (see Functional Block Diagrams).

Package Type

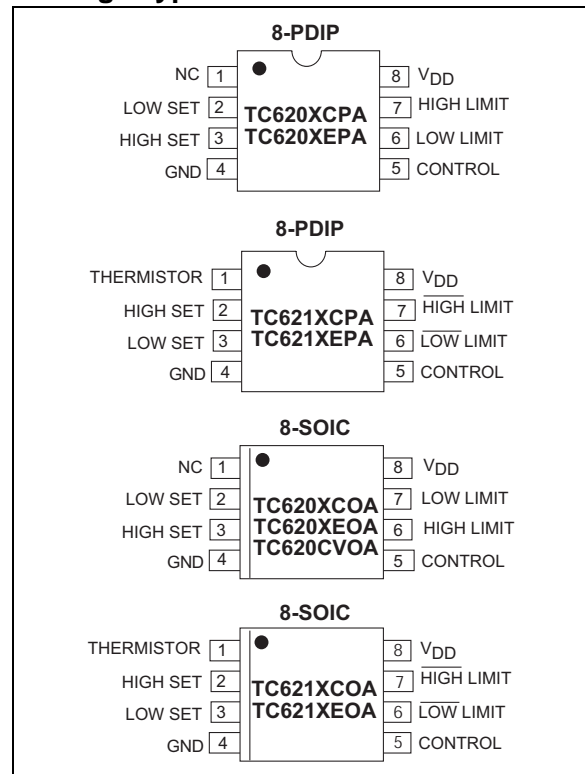

General Description:

The TC620 and TC621 are programmable logic output temperature detectors designed for use in thermal management applications. The TC620 features an onboard temperature sensor, while the TC621 connects to an external NTC thermistor for remote sensing applications.

Both devices feature dual thermal interrupt outputs (HIGH LIMIT and LOW LIMIT), each of which is programmed with a single external resistor. On the TC620, these outputs are driven active (high) when measured temperature equals the user programmed limits. The CONTROL (hysteresis) output is driven high when temperature equals the high limit setting and returns low when temperature falls below the low limit setting. This output can be used to provide ON/OFF control to a cooling fan or heater. The TC621 provides the same output functions except that the logical states are inverted.

The TC620/TC621 are usable over operating temperature ranges of 0°C to 70°C, -40°C to +125°C and -55°C to 125°C.

TC620/TC621

Functional Block Diagrams

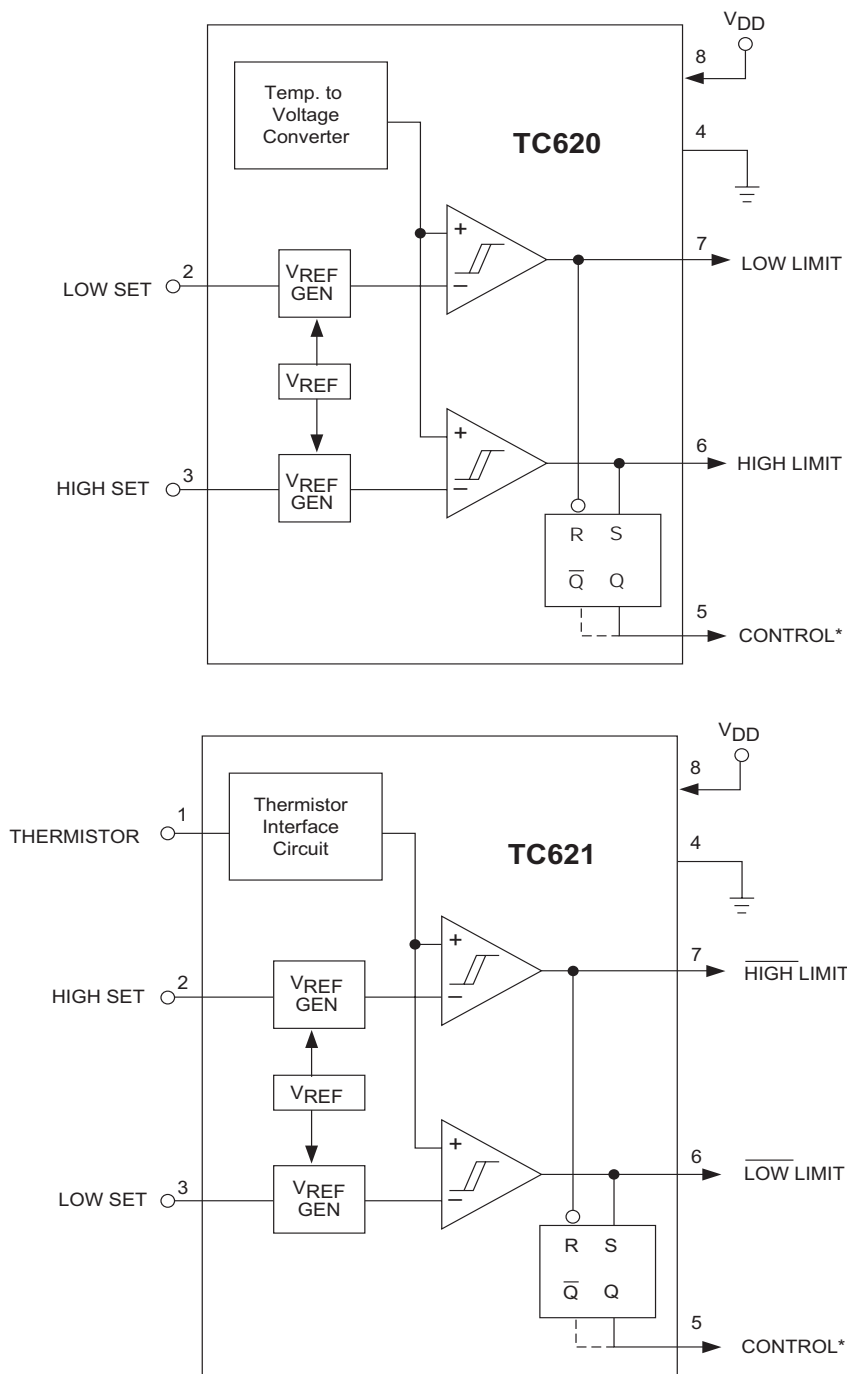

*Suffix code "C" denotes cooling option (High true CONTROL output).
 Suffix code "H" denotes heating option (Low true CONTROL output).

1.0 ELECTRICAL CHARACTERISTICS

Absolute Maximum Ratings*

Supply Voltage	20V
Input Voltage Any Input.. (GND – 0.3V) to (V _{DD} +0.3V)	
Package Power Dissipation (T _A ≤ 70°C)	
PDIP	730 mW
SOIC	470 mW
Derating Factors:	
Plastic	8 mW/°C
Operating Temperature:	
M Version	-55°C to +125°C
V Version	-40°C to +125°C
E Version	-40°C to +85°C
C Version	0°C to +70°C
Storage Temperature	-65°C to +150°C

*Stresses above those listed under “Absolute Maximum Ratings” may cause permanent damage to the device. These are stress ratings only and functional operation of the device at these or any other conditions above those indicated in the operation sections of the specifications is not implied. Exposure to Absolute Maximum Rating conditions for extended periods may affect device reliability.

TC620/TC621 ELECTRICAL SPECIFICATIONS

Electrical Characteristics: T _A = 25°C, unless otherwise specified.						
Symbol	Parameter	Min	Typ	Max	Unit	Test Conditions
V _{DD}	Supply Voltage Range	4.5	—	18	V	
I _{DD}	Supply Current	—	270	400	μA	5V ≤ V _{DD} ≤ 18V
R _{OUT}	Output Resistance	—	400	1000	Ω	Output High or Low, 5V ≤ V _{DD} ≤ 18V
I _{OUT}	Output Current	—	—	1	mA	Temp. Sensed Source/Sink
I _{OUT}	Output Current	—	—	1	mA	Cool/Heat Source/Sink
T _{ERR}	Absolute Accuracy	T - 3	T	T + 3	°C	T = Programmed Temperature

TC620/TC621

2.0 PIN DESCRIPTIONS

The descriptions of the pins are listed in Table 2-1.

TABLE 2-1: PIN FUNCTION TABLE

Pin No. (8-Pin PDIP) (8-Pin SOIC) 0°C to +70°C -40°C to +85°C -40°C to +125°C	Symbol	Description
1	NC	No Internal Connection.
2	LOW SET	Low temperature set point. Connect an external 1% resistor from LOW SET to V_{DD} to set trip point.
3	HIGH SET	High temperature set point. Connect an external 1% resistor from HIGH SET to V_{DD} to set trip point.
4	GND	Ground Terminal.
5	CONTROL	Control output.
6	HIGH LIMIT	High temperature push/pull output.
7	LOW LIMIT	Low temperature push/pull output.
8	V_{DD}	Power supply input.

Pin No. (8-Pin PDIP) (8-Pin SOIC) 0°C to +70°C -40°C to +85°C	Symbol	Description
1	THERMISTOR	Thermistor input.
2	HIGH SET	High temperature set point. Connect an external 1% resistor from HIGH SET to V_{DD} to set trip point.
3	LOW SET	Low temperature set point. Connect an external 1% resistor from LOW SET to V_{DD} to set trip point.
4	GND	Ground Terminal.
5	CONTROL	Control output.
6	$\overline{\text{LOW}} \text{ LIMIT}$	Low temperature push/pull output.
7	$\overline{\text{HIGH}} \text{ LIMIT}$	High temperature push/pull output.
8	V_{DD}	Power supply input.

3.0 DETAILED DESCRIPTION

The TC620 has a positive temperature coefficient temperature sensor and a dual threshold detector. Temperature set point programming is accomplished with external resistors from the HIGH SET and LOW SET inputs to V_{DD} . The HIGH LIMIT and LOW LIMIT outputs remain low as long as measured temperature is below set point values. As measured temperature increases, the LOW LIMIT output is driven high when temperature equals the LOW SET set point ($\pm 3^\circ\text{C}$ max). If temperature continues to climb, the HIGH LIMIT output is driven high when temperature equals the HIGH SET set point (Figure 3-1). The CONTROL (hysteresis) output is latched in its active state at the temperature specified by the HIGH SET resistor. CONTROL is maintained active until temperature falls to the value specified by the LOW SET resistor.

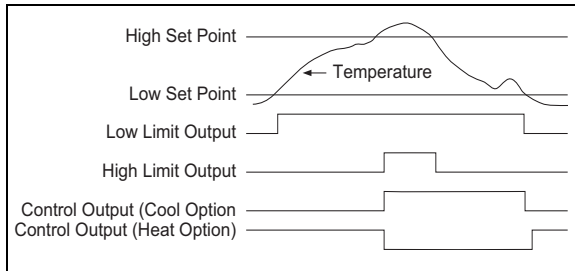

FIGURE 3-1: TC620/TC621 Input vs. Output Logic

3.1 Programming the TC620

The resistor values to achieve the desired trip point temperatures on HIGH SET and LOW SET are calculated using Equation 3-1:

EQUATION 3-1:

$$R_{TRIP} = 0.5997 \times T^{2.1312}$$

Where:

R_{TRIP} = Programming resistor in Ohms
 T = The desired trip point temperature in degrees Kelvin.

For example, a 50°C setting on either the HIGH SET or LOW SET input is calculated using Equation 3-2 as follows:

EQUATION 3-2:

$$R_{SET} = 0.5997 \times ((50 + 273.15)^{2.1312}) = 133.6 \text{ k}\Omega$$

Care must be taken to ensure the LOW SET programming resistor is a smaller value than the HIGH SET programming resistor. Failure to do this will result in erroneous operation of the CONTROL output.

Care must also be taken to ensure the LOW SET temperature setting is at least 5°C lower than the HIGH SET temperature setting.

Figure 3-2 can help the user obtain an estimate of the external resistor values required for the desired LOW SET and HIGH SET trip points.

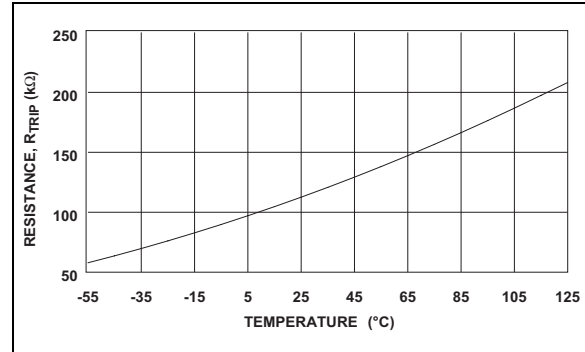

FIGURE 3-2: TC620 Sense Resistors vs. Trip Temperature

3.2 Built-in Hysteresis

To prevent output “chattering” when measured temperature is at (or near) the programmed trip point values, the LOW SET and HIGH SET inputs each have built-in hysteresis of -2°C below the programmed settings (Figure 3-3).

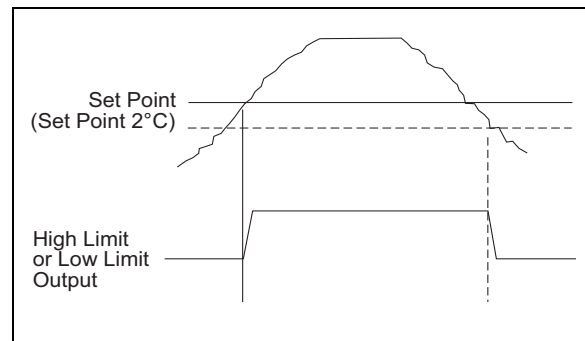

FIGURE 3-3: Built-In Hysteresis on Low Limit and High Limit Outputs

As shown, the outputs remain in their active state (hysteresis) until temperature falls an additional 2°C below the user’s setting.

TC620/TC621

3.3 Using the TC621

The TC621 operation is similar to that of the TC620, but requires an external NTC thermistor. Use the resistance versus temperature curve of the thermistor to determine the values of the programming resistors. Note that the pin numbers for the HIGH SET and LOW SET programming resistors for the TC621 are reversed versus that of the TC620 (i.e., the resistor value on HIGH SET [Pin 2] should always be lower than the one connected to LOW SET [Pin 3]). Also note that the outputs of the TC621 are LOW TRUE when used with an NTC thermistor.

3.4 TC621 Thermistor Selection

The TC621 uses an external thermistor to monitor the controlling temperature. A thermistor with a resistance value of approximately 100 k Ω at 25°C is recommended.

A temperature set point is selected by picking a resistor whose value is equal to the resistance of the thermistor at the desired temperature. For example, using the data shown in Figure 3-4, a 30 k Ω resistor between HIGH TEMP (Pin 2) and V_{DD} (Pin 8) sets the high temperature trip point at +51°C and a 49 k Ω resistor on LOW TEMP (Pin 3) sets the low temperature trip point to +41°C.

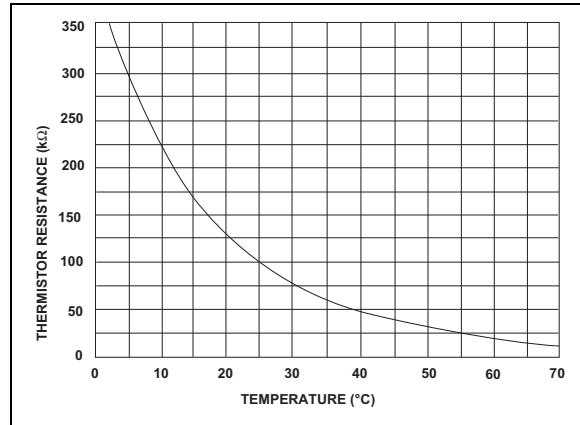

FIGURE 3-4: Typical NTC Thermistor

3.5 TC620/TC621 Outputs

Both devices have complimentary output stages. They are rated at a source or sink current of 1 mA maximum.

4.0 TYPICAL APPLICATIONS

4.1 Dual Speed Temperature Control

In Figure 4-1, the Dual Speed Temperature Control uses a TC620 and a TC4469 quad driver. Two of the drivers of the TC4469 are configured in a simple oscillator. When the temperature is below the LOW TEMP set point, the output of the driver is OFF. When the temperature exceeds the LOW TEMP set point, the TC4469 gates the oscillator signal to the outputs of the driver. This square wave signal modulates the remaining outputs and drives the motor at a low speed. If this speed cannot keep the temperature below the HIGH TEMP set point, then the driver turns on continuously which increases the fan speed to high. The TC620 will monitor the temperature and only allow the fan to operate when needed and at the required speed to maintain the desired temperature. A higher power option can be designed by adding a resistor and a power MOSFET.

4.2 Temperature Controlled Fan

In the application in Figure 4-2, a high and a low temperature is selected by two R_L and R_H . The TC620 monitors the ambient temperature and turns the FET switch on when the temperature exceeds the HIGH TEMP set point. The fan remains on until the temperature decreases to the LOW TEMP set point. This provides the hysteresis. In this application, the fan turns on only when required.

The TC621 uses an external thermistor to monitor the ambient temperature. This adds one part, but allows more flexibility with the location of the temperature sensor.

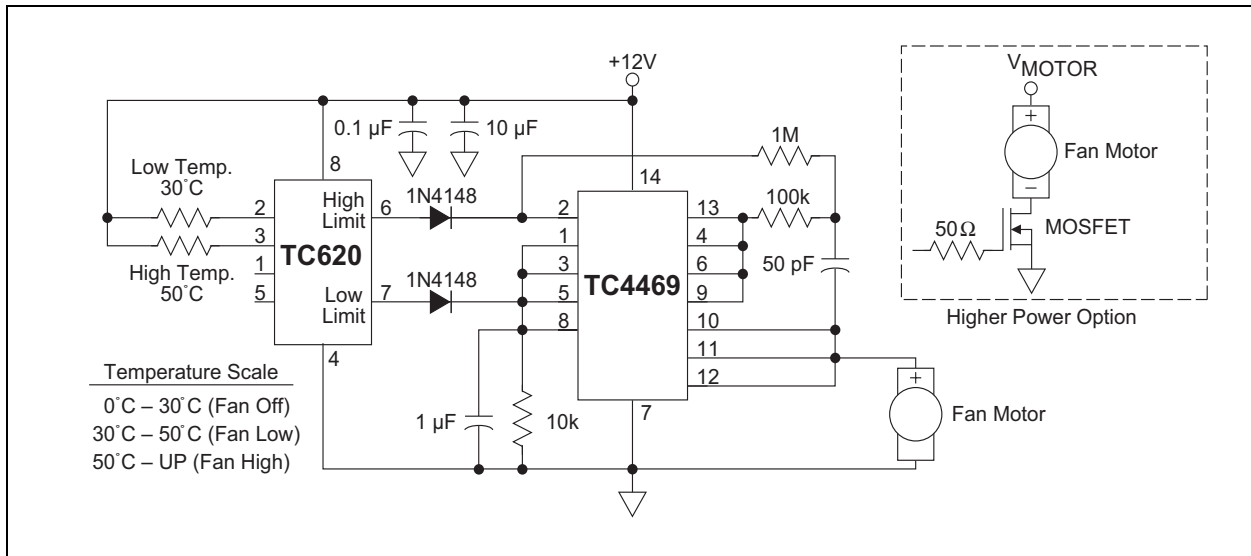

FIGURE 4-1: Dual Speed Temperature Control

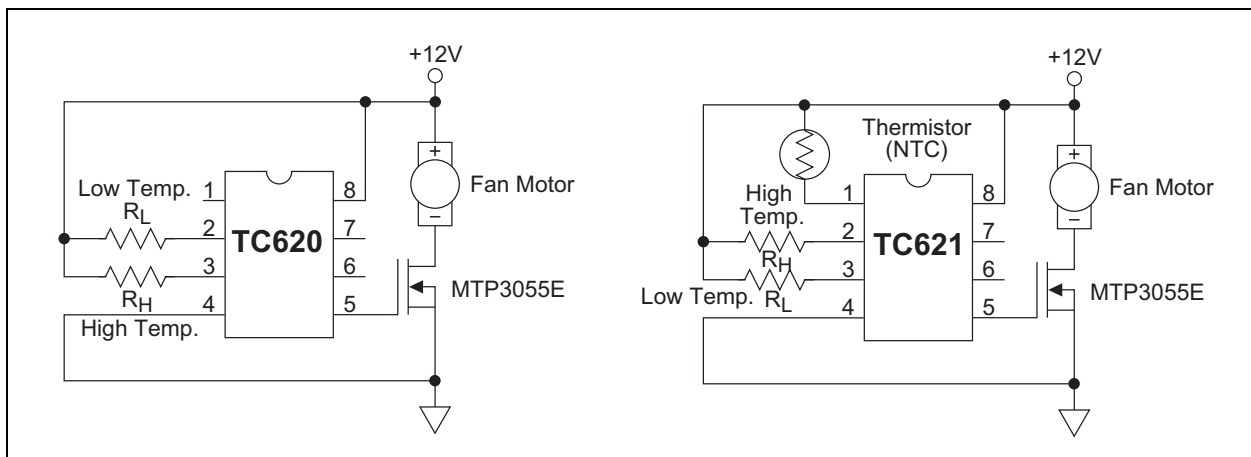

FIGURE 4-2: Temperature Controlled Fan

TC620/TC621

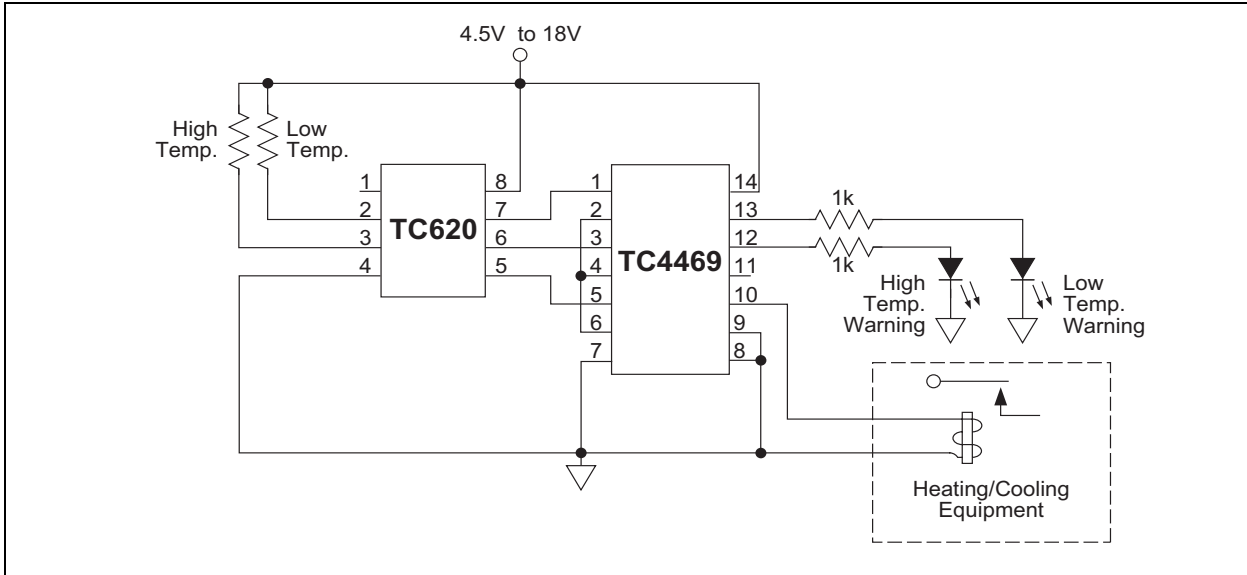

FIGURE 4-3: Heating and Cooling Application

5.0 PACKAGING INFORMATION

5.1 Package Marking Information

Package marking data not available at this time.

5.2 Taping Form

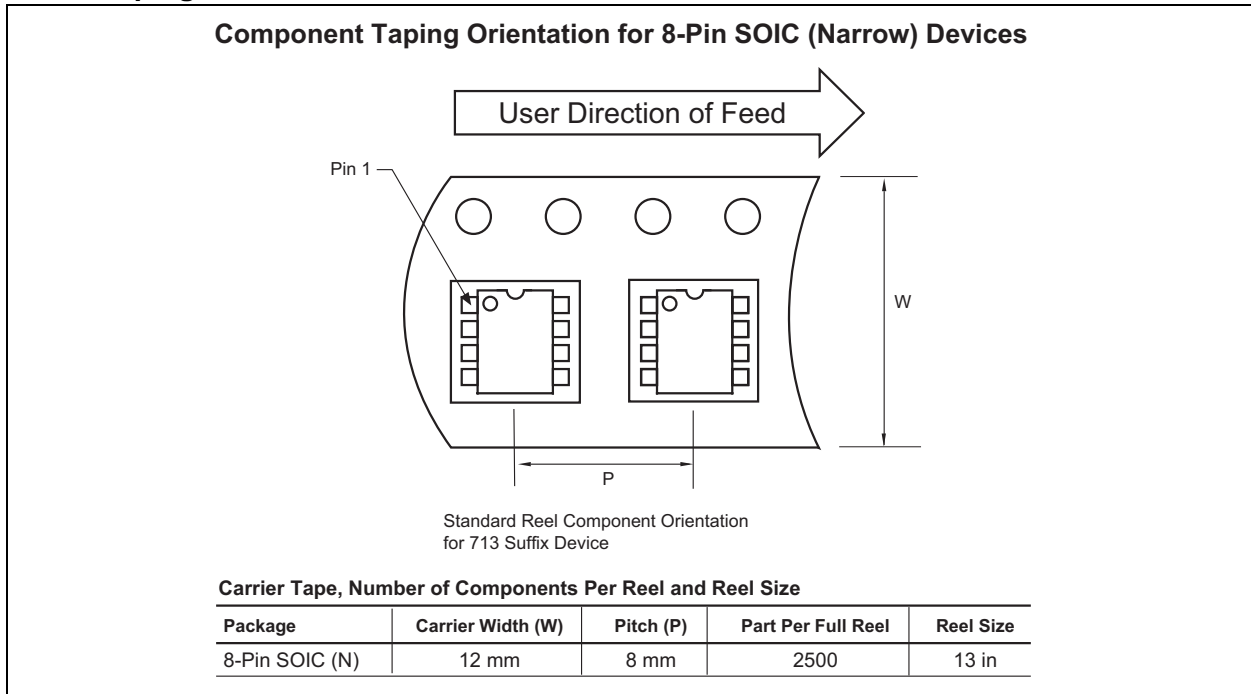

5.3 Package Dimensions

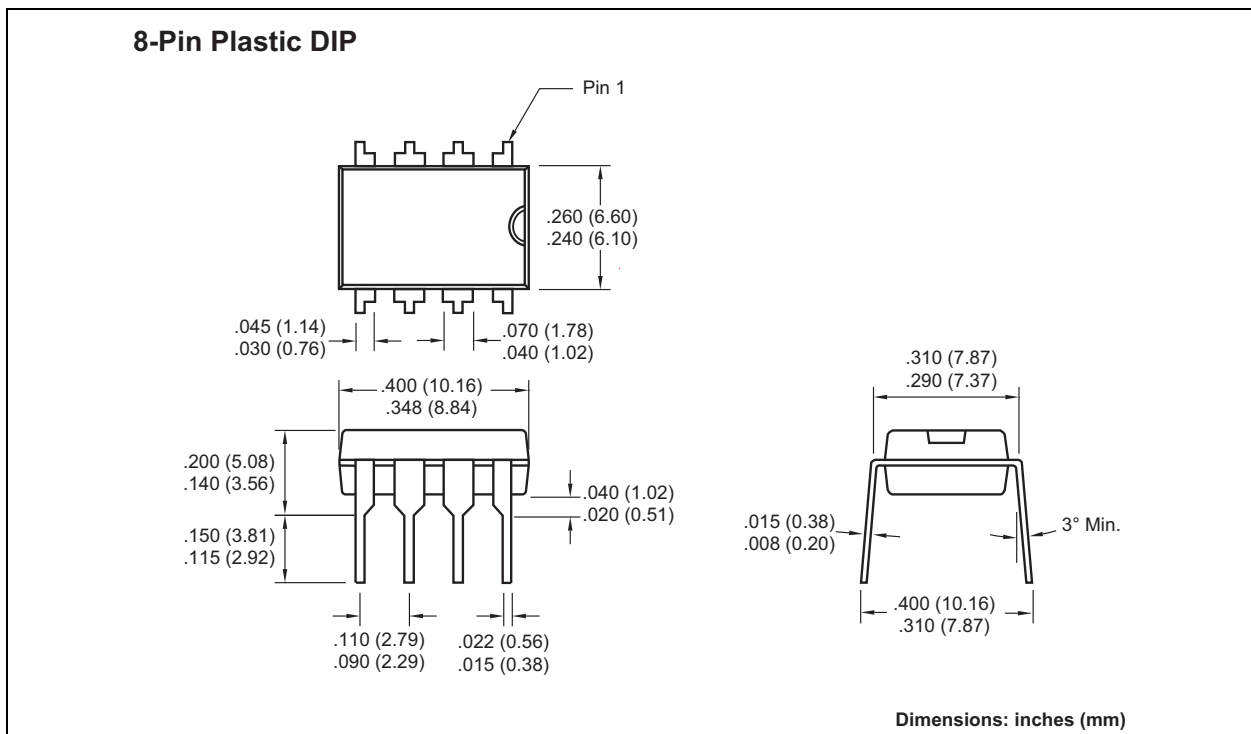

TC620/TC621

Package Dimensions (Continued)

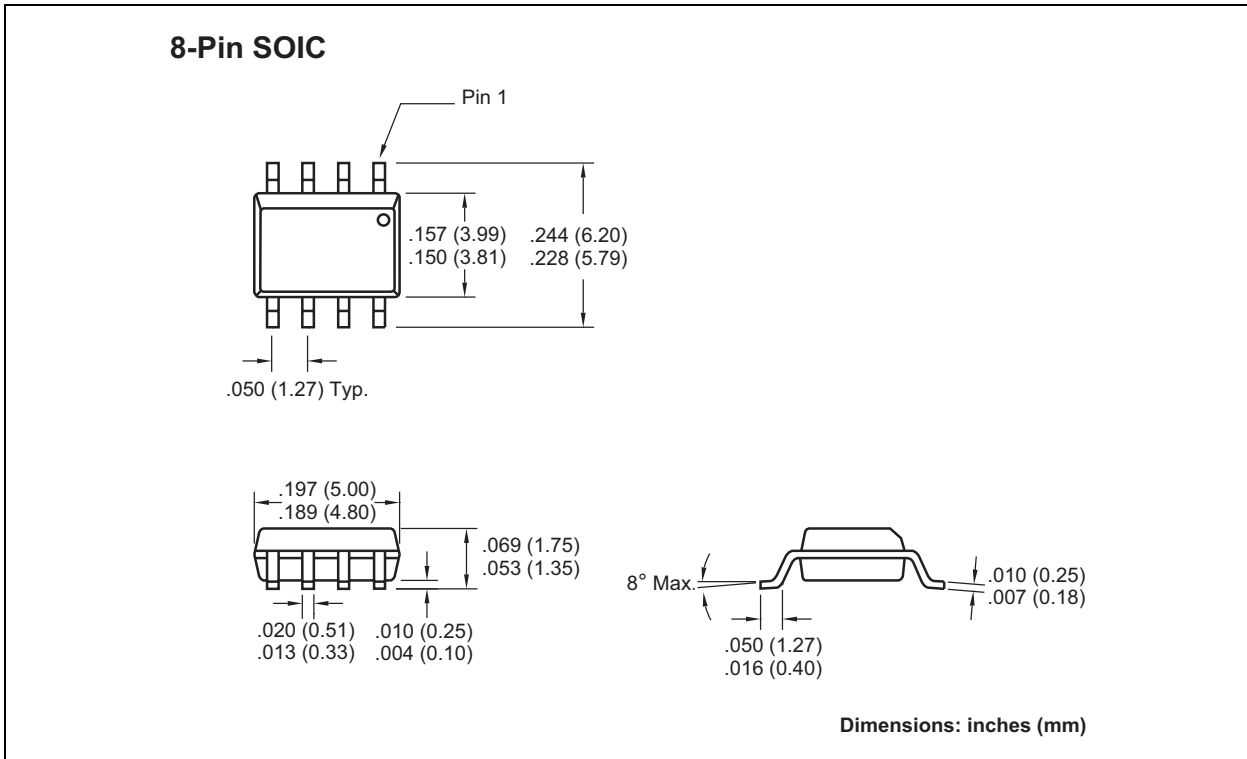

SALES AND SUPPORT

Data Sheets

Products supported by a preliminary Data Sheet may have an errata sheet describing minor operational differences and recommended workarounds. To determine if an errata sheet exists for a particular device, please contact one of the following:

1. Your local Microchip sales office
2. The Microchip Corporate Literature Center U.S. FAX: (480) 792-7277
3. The Microchip Worldwide Site (www.microchip.com)

Please specify which device, revision of silicon and Data Sheet (include Literature #) you are using.

New Customer Notification System

Register on our web site (www.microchip.com/cn) to receive the most current information on our products.

TC620/TC621

NOTES:

Note the following details of the code protection feature on Microchip devices:

- Microchip products meet the specification contained in their particular Microchip Data Sheet.
- Microchip believes that its family of products is one of the most secure families of its kind on the market today, when used in the intended manner and under normal conditions.
- There are dishonest and possibly illegal methods used to breach the code protection feature. All of these methods, to our knowledge, require using the Microchip products in a manner outside the operating specifications contained in Microchip's Data Sheets. Most likely, the person doing so is engaged in theft of intellectual property.
- Microchip is willing to work with the customer who is concerned about the integrity of their code.
- Neither Microchip nor any other semiconductor manufacturer can guarantee the security of their code. Code protection does not mean that we are guaranteeing the product as “unbreakable.”

Code protection is constantly evolving. We at Microchip are committed to continuously improving the code protection features of our products. Attempts to break Microchip's code protection feature may be a violation of the Digital Millennium Copyright Act. If such acts allow unauthorized access to your software or other copyrighted work, you may have a right to sue for relief under that Act.

Information contained in this publication regarding device applications and the like is provided only for your convenience and may be superseded by updates. It is your responsibility to ensure that your application meets with your specifications. MICROCHIP MAKES NO REPRESENTATIONS OR WARRANTIES OF ANY KIND WHETHER EXPRESS OR IMPLIED, WRITTEN OR ORAL, STATUTORY OR OTHERWISE, RELATED TO THE INFORMATION, INCLUDING BUT NOT LIMITED TO ITS CONDITION, QUALITY, PERFORMANCE, MERCHANTABILITY OR FITNESS FOR PURPOSE. Microchip disclaims all liability arising from this information and its use. Use of Microchip's products as critical components in life support systems is not authorized except with express written approval by Microchip. No licenses are conveyed, implicitly or otherwise, under any Microchip intellectual property rights.

Trademarks

The Microchip name and logo, the Microchip logo, Accuron, dsPIC, KEELOQ, microID, MPLAB, PIC, PICmicro, PICSTART, PRO MATE, PowerSmart, rPIC, and SmartShunt are registered trademarks of Microchip Technology Incorporated in the U.S.A. and other countries.

AmpLab, FilterLab, Migratable Memory, MXDEV, MXLAB, SEEVAL, SmartSensor and The Embedded Control Solutions Company are registered trademarks of Microchip Technology Incorporated in the U.S.A.

Analog-for-the-Digital Age, Application Maestro, dsPICDEM, dsPICDEM.net, dsPICworks, ECAN, ECONOMONITOR, FanSense, FlexROM, fuzzyLAB, In-Circuit Serial Programming, ICSP, ICEPIC, Linear Active Thermistor, MPASM, MPLIB, MPLINK, MPSIM, PICkit, PICDEM, PICDEM.net, PICLAB, PICtail, PowerCal, PowerInfo, PowerMate, PowerTool, Real ICE, rLAB, rPICDEM, Select Mode, Smart Serial, SmartTel, Total Endurance, UNI/O, WiperLock and Zena are trademarks of Microchip Technology Incorporated in the U.S.A. and other countries.

SQTP is a service mark of Microchip Technology Incorporated in the U.S.A.

All other trademarks mentioned herein are property of their respective companies.

© 2006, Microchip Technology Incorporated, Printed in the U.S.A., All Rights Reserved.

 Printed on recycled paper.

**QUALITY MANAGEMENT SYSTEM
CERTIFIED BY DNV
== ISO/TS 16949:2002 ==**

Microchip received ISO/TS-16949:2002 quality system certification for its worldwide headquarters, design and wafer fabrication facilities in Chandler and Tempe, Arizona and Mountain View, California in October 2003. The Company's quality system processes and procedures are for its PICmicro® 8-bit MCUs, KEELOQ® code hopping devices, Serial EEPROMs, microperipherals, nonvolatile memory and analog products. In addition, Microchip's quality system for the design and manufacture of development systems is ISO 9001:2000 certified.



WORLDWIDE SALES AND SERVICE

AMERICAS

Corporate Office
2355 West Chandler Blvd.
Chandler, AZ 85224-6199
Tel: 480-792-7200
Fax: 480-792-7277
Technical Support:
<http://support.microchip.com>
Web Address:
www.microchip.com

Atlanta
Alpharetta, GA
Tel: 770-640-0034
Fax: 770-640-0307

Boston
Westborough, MA
Tel: 774-760-0087
Fax: 774-760-0088

Chicago
Itasca, IL
Tel: 630-285-0071
Fax: 630-285-0075

Dallas
Addison, TX
Tel: 972-818-7423
Fax: 972-818-2924

Detroit
Farmington Hills, MI
Tel: 248-538-2250
Fax: 248-538-2260

Kokomo
Kokomo, IN
Tel: 765-864-8360
Fax: 765-864-8387

Los Angeles
Mission Viejo, CA
Tel: 949-462-9523
Fax: 949-462-9608

San Jose
Mountain View, CA
Tel: 650-215-1444
Fax: 650-961-0286

Toronto
Mississauga, Ontario,
Canada
Tel: 905-673-0699
Fax: 905-673-6509

ASIA/PACIFIC

Australia - Sydney
Tel: 61-2-9868-6733
Fax: 61-2-9868-6755

China - Beijing
Tel: 86-10-8528-2100
Fax: 86-10-8528-2104

China - Chengdu
Tel: 86-28-8676-6200
Fax: 86-28-8676-6599

China - Fuzhou
Tel: 86-591-8750-3506
Fax: 86-591-8750-3521

China - Hong Kong SAR
Tel: 852-2401-1200
Fax: 852-2401-3431

China - Qingdao
Tel: 86-532-8502-7355
Fax: 86-532-8502-7205

China - Shanghai
Tel: 86-21-5407-5533
Fax: 86-21-5407-5066

China - Shenyang
Tel: 86-24-2334-2829
Fax: 86-24-2334-2393

China - Shenzhen
Tel: 86-755-8203-2660
Fax: 86-755-8203-1760

China - Shunde
Tel: 86-757-2839-5507
Fax: 86-757-2839-5571

China - Wuhan
Tel: 86-27-5980-5300
Fax: 86-27-5980-5118

China - Xian
Tel: 86-29-8833-7250
Fax: 86-29-8833-7256

ASIA/PACIFIC

India - Bangalore
Tel: 91-80-2229-0061
Fax: 91-80-2229-0062

India - New Delhi
Tel: 91-11-5160-8631
Fax: 91-11-5160-8632

India - Pune
Tel: 91-20-2566-1512
Fax: 91-20-2566-1513

Japan - Yokohama
Tel: 81-45-471- 6166
Fax: 81-45-471-6122

Korea - Gumi
Tel: 82-54-473-4301
Fax: 82-54-473-4302

Korea - Seoul
Tel: 82-2-554-7200
Fax: 82-2-558-5932 or
82-2-558-5934

Malaysia - Penang
Tel: 60-4-646-8870
Fax: 60-4-646-5086

Philippines - Manila
Tel: 63-2-634-9065
Fax: 63-2-634-9069

Singapore
Tel: 65-6334-8870
Fax: 65-6334-8850

Taiwan - Hsin Chu
Tel: 886-3-572-9526
Fax: 886-3-572-6459

Taiwan - Kaohsiung
Tel: 886-7-536-4818
Fax: 886-7-536-4803

Taiwan - Taipei
Tel: 886-2-2500-6610
Fax: 886-2-2508-0102

Thailand - Bangkok
Tel: 66-2-694-1351
Fax: 66-2-694-1350

EUROPE

Austria - Wels
Tel: 43-7242-2244-399
Fax: 43-7242-2244-393

Denmark - Copenhagen
Tel: 45-4450-2828
Fax: 45-4485-2829

France - Paris
Tel: 33-1-69-53-63-20
Fax: 33-1-69-30-90-79

Germany - Munich
Tel: 49-89-627-144-0
Fax: 49-89-627-144-44

Italy - Milan
Tel: 39-0331-742611
Fax: 39-0331-466781

Netherlands - Drunen
Tel: 31-416-690399
Fax: 31-416-690340

Spain - Madrid
Tel: 34-91-708-08-90
Fax: 34-91-708-08-91

UK - Wokingham
Tel: 44-118-921-5869
Fax: 44-118-921-5820

10/31/05