



Lead Free Thin Film Chip Fuse

Document No	TCFS-12OS051D
Issued date	2007/7/25
Page	1/15

1. Scope

This specification applies for the Lead-Free fuse series of thin film chip fuse made by TA-I.

2. Construction

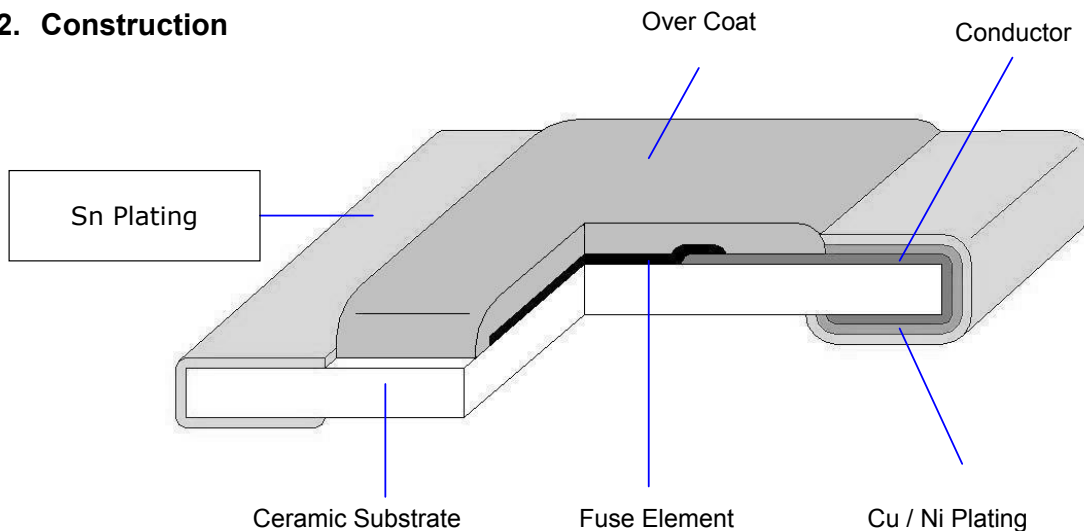

3. Type Designation

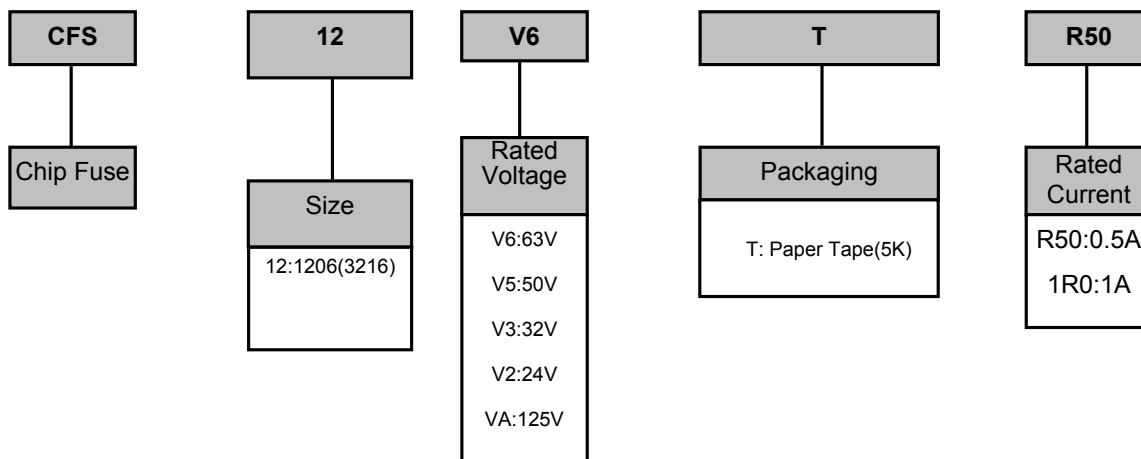



Lead Free Thin Film Chip Fuse

Document No	TCFS-12OS051D
Issued date	2007/7/25
Page	2/15

4. Dimensions

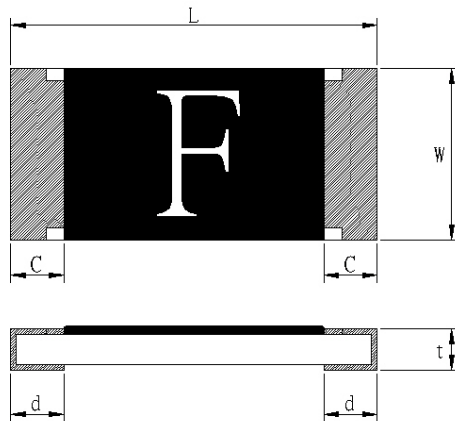

Unit: mm

Type (Inch Size code)	Dimensions (mm)				
	L	W	C	d	t
CFS12V (1206)	3.1±0.1	1.55±0.1	0.5±0.3	0.5±0.2	0.6±0.1

5. Applications and ratings

Part Designation	Marking	Rated Current	Fusing Time	Resistance (mΩ) Typ.*	Rated Voltage	Breaking Capacity	Body Temperature rising
CFS12V6TR50	F	0.50A	Open within 5sec.at250% rated current	385	DC 63V	DC63V 50A	<75°C at 100% rated current
CFS12V6TR80	K	0.80A		165			
CFS12V6T1R0	L	1.00A		108			
CFS12V6T1R25	M	1.25A		76			
CFS12V6T1R50	P	1.50A		51			
CFS12V6T2R0	S	2.00A		32			
CFS12V3T2R50	T	2.50A		26	DC 32V	DC32V 50A	
CFS12V3T3R00	3	3.00A		20			
CFS12V2T4R0	W	4.00A		14			
CFS12V2T5R0	Y	5.00A		10	DC 24V	DC24V 50A	
CFS12V2T7R0	Z	7.00A		6.5			

*Resistance value was measured with less than 10% of rated current



Lead Free Thin Film Chip Fuse

Document No	TCFS-12OS051D
Issued date	2007/7/25
Page	3/15

6. Temperature Derating Curve

6.1 Normal Ambient Temperature: 25°C

6.2 Operating Temperature: -20°C~105°C, with proper Derating factor as below:

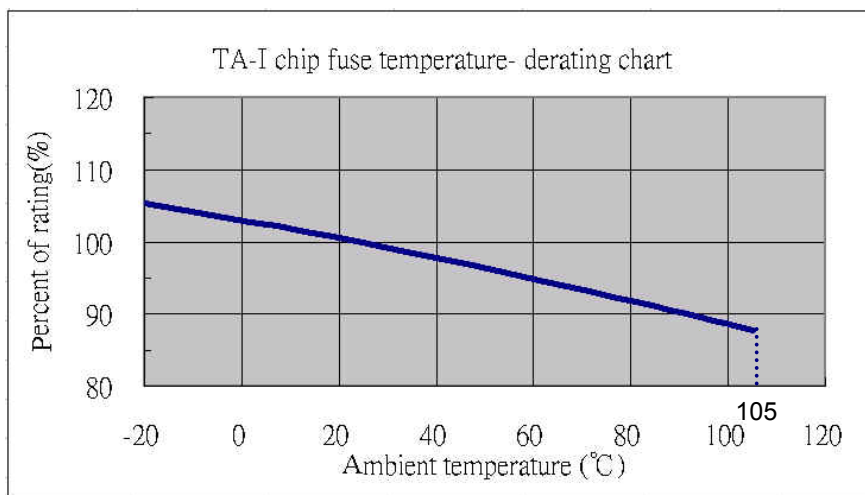

7. Reliability Tests

Parameter	Requirement	Test Method
Carrying capacity	No fusing	Rated current ,4hr
Fusing Time	Within 5sec	250% of its rated current
Interrupting Ability	No mechanical damages	After the fuse is interrupted ,rated voltage applied for 30sec again
Bending Test	No mechanical damages	Distance between holding points: 90mm, Bending:3mm,1time ,30sec
Resistance to solder Heat	±20%	260°C±5°C,10seconds ±1second
Solder ability	95% coverage minimum	235°C±5°C, 2±0.5second 245°C±5°C, 2±0.5second (Lead Free)
Temperature Rise	<75°C	100% of its rated current, Measure of surface temperature
Resistance to Dry Heat	±20%	105°C±5°C,1000 hrs
Resistance to Solvent	No evident damages on protective coating and marking	23°C±5°C of Isopropyl alcohol 90second
Residual Resistance	10kΩ and more	Measure DC resistance after fusing
Thermal Shock	ΔR< 10 %	-20°C/ +25°C/+125°C/+25°C , 10 cycles



Lead Free Thin Film Chip Fuse

Document No	TCFS-12OS051D
Issued date	2007/7/25
Page	4/15

8. Marking

Symbol for Rating Current

Symbol	F	I	K	L	<u>M</u>	P	N	S	T	3	U	W	Y	Z
Rating Current(A)	0.5	0.63	0.8	1	1.25	1.5	1.6	2	2.5	3	3.15	4	5	7

9. Taping & Reel

9.1 Taping Dimensions

4mm pitch paper

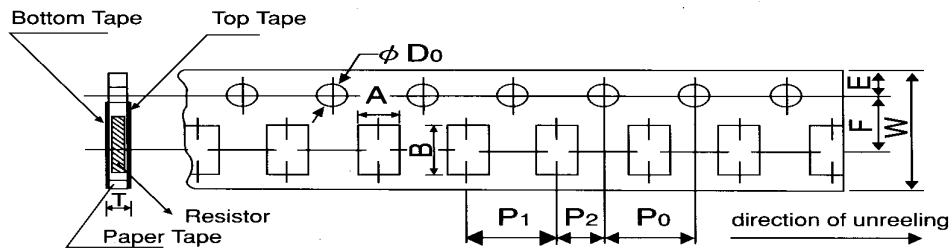

Packing	Type	A	B	W	F	E	P ₁	P ₂	P ₀	D ₀	T
Paper Tape	CFS12V	2.0±0.15	3.6±0.2	8.0±0.2	3.5±0.05	1.75±0.1	4.0±0.1	2.0±0.05	4.0±0.1	ϕ 1.5 ^{+0.1} ₋₀	0.84±0.1

Unit: mm

Type series		Paper Tape
		4 mm pitch
		180mm/R
CFS	12V	5000



Lead Free Thin Film Chip Fuse

Document No	TCFS-12OS051D
Issued date	2007/7/25
Page	5/15

9.2 Reel Specifications

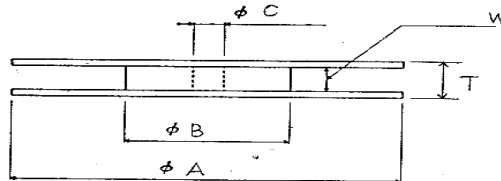
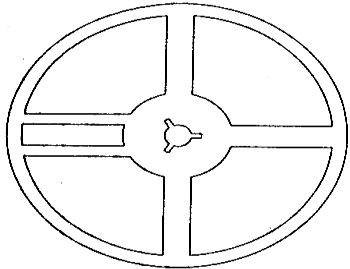

Unit: mm

Series	ϕA	ϕB	ϕC	W	T
CFS12V	180 ⁺⁰ ₋₃	60 min	13.0±1.0	9.0±1.0	11.4±2.0

9.3 Peel –off force :

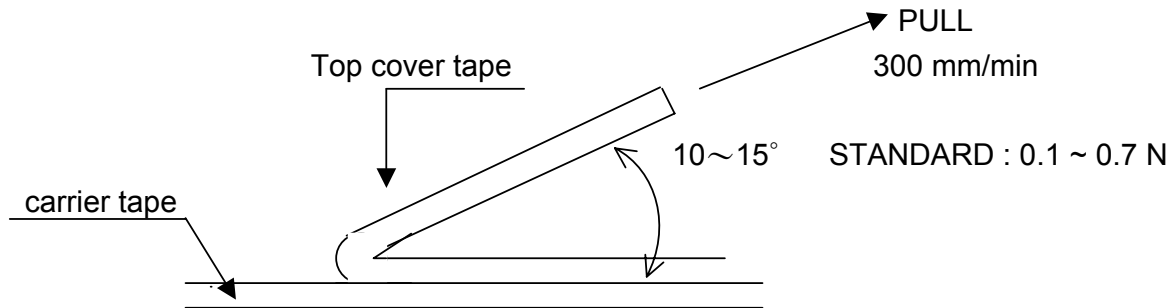

10. Storage Conditions:

Temperature: 5°C~35°C, Humidity:40%~75%

11. Shelf Life:

2 years from manufacturing date



Lead Free Thin Film Chip Fuse

Document No	TCFS-12OS051D
Issued date	2007/7/25
Page	6/15

12. Label

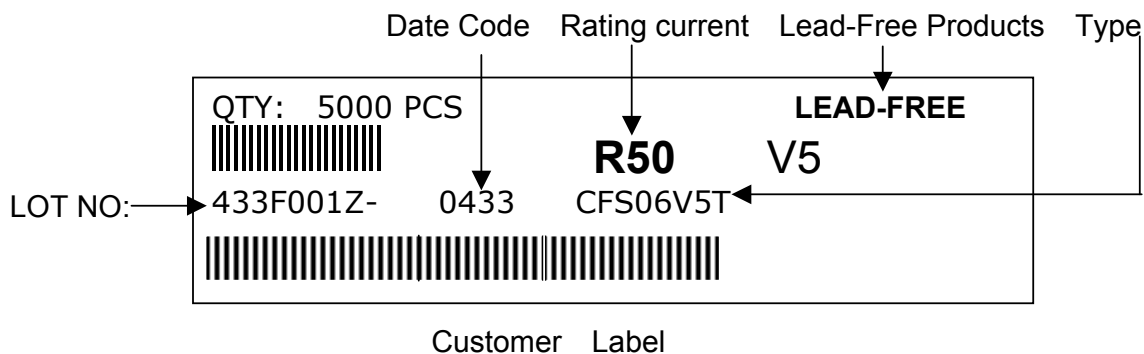

13. Recommended land patterns

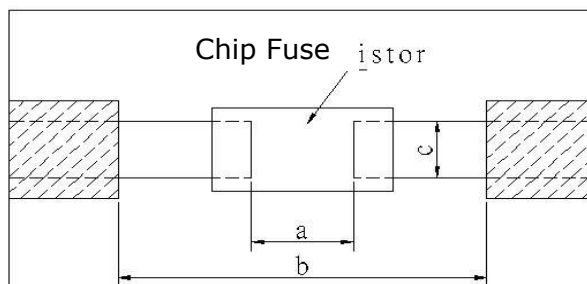

Type	Land pattern Size	Dimension		
		a	b	c
CFS	12 (1206)	2.0~2.4	4.4~5.0	1.2~1.8



Document No	TCFS-12OS051D
Issued date	2007/7/25
Page	7/15

14. Recommend IR – Reflow profile : (solder : Sn96.5 / Ag3 / Cu0.5)

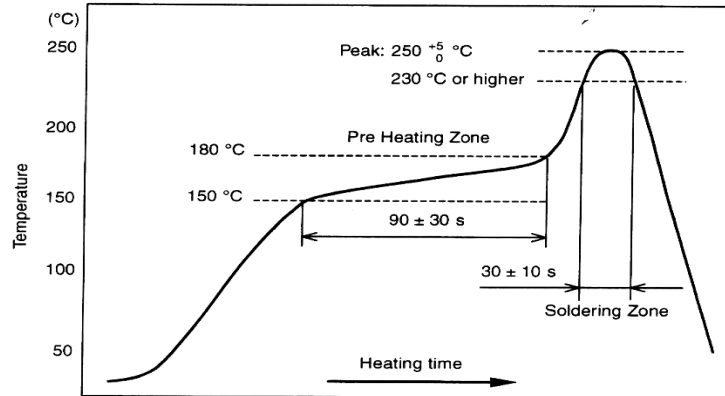

Peak : $250 \begin{matrix} +5 \\ -0 \end{matrix} ^\circ\text{C}$, 5 sec

Pre – heat Zone : 150 to 180 °C, 90±30 sec

Soldering Zone : 230°C or higher , 30±10 sec

15. Approval by UL248-14

The fuses have been approved by UL.

File No. of UL Recognition is E241710

16. ECN

Engineering Change Notice: The customer will be informed with ECN if there is significant modification on the characteristics and materials described in Approval Sheet.

17. Manufacturing Country & City :

TA-I TECHNOLOGY CO., LTD. (Taiwan – Tao Yuan)

Tel: 886-3-3246169 Fax : 886-3-3246167

Associated companies :

(1) FORTUNE TASK RESISTOR FACTORY (China – Dong Guan)

Tel : 86-769-83394790 Fax : 86-769-83394794

(2) TA-I TECHNOLOGY (SU ZHOU) CO., LTD. (China – Su Zhou)

Tel :86- 512-63457879 Fax : 86-512-63457869

(3) TAI OHM ELECTRONICS (M) SDN. BHD. (Malaysia – Pulaupinang)

Tel :604- 3900480 Fax : 604-3901481

(4) P.T.TAI ELECTRONICS Indonesia (Indonesia – Jakarta)

Tel :002-62-21-44820254 Fax : 002-62-21-44820256



Document No	TCFS-12OS051D
Issued date	2007/7/25
Page	8/15

★ Selection Guideline of Fuse:

■ Checklist of selection factors

- ⊙ Normal operating current
- ⊙ Normal operating voltage (AC or DC)
- ⊙ Ambient Temperature
- ⊙ Overload current and length of time in which the fuse must open .
- ⊙ Type of fuse (SMD or Tube) and physical size limitation (0603 or 1206)
- ⊙ Agency Approval required (e.g., UL248-14)

■ Normal operating current

e.g., Rectangular Wave , If $I_p = 1.5 A$, Normal operating current = 1.5 A

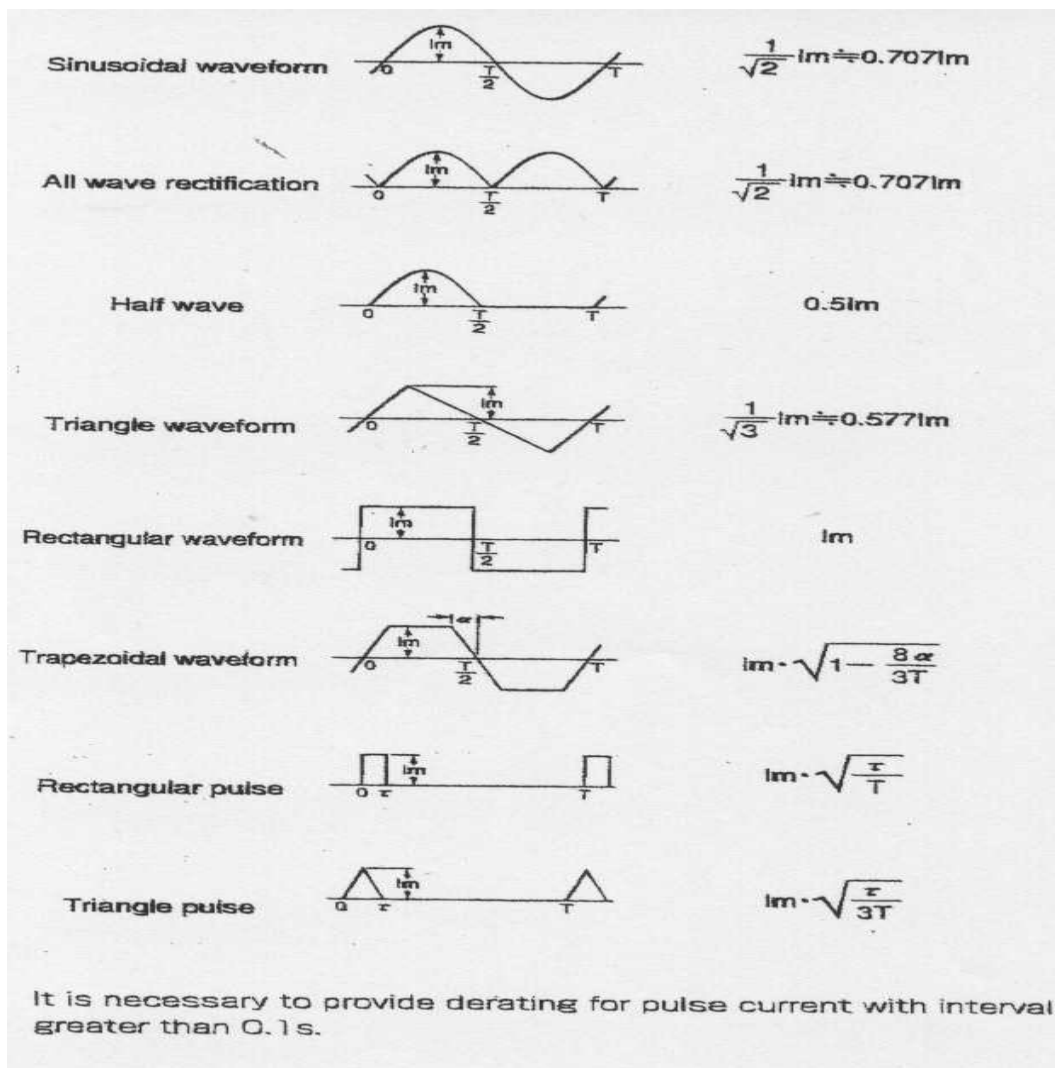



Lead Free Thin Film Chip Fuse

Document No	TCFS-12OS051D
Issued date	2007/7/25
Page	9/15

Derating ratio for different ambient Temperature

- Referring to bottom figure and select the appropriate derating ratio :
e.g., Ambient temperature is 60 degree C
the derating ratio \approx 0.95

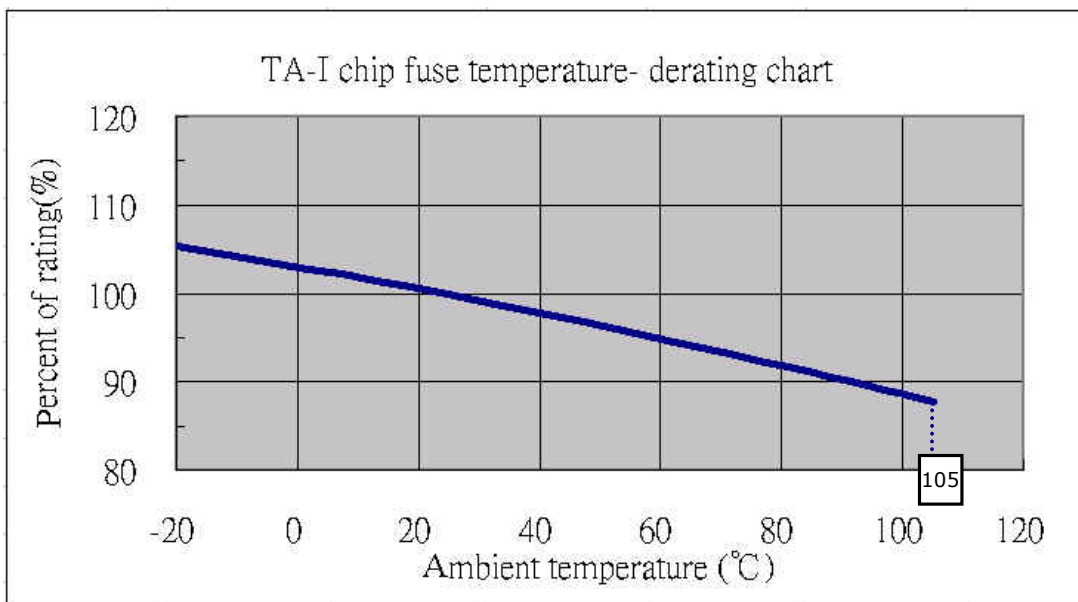

Calculating the required rating of fuse needed .

- Safety coefficient : 70 % is safety coefficient from practical experience

$$\frac{\text{Normal Operating Current}}{0.7 \times \text{derating ratio}} < \text{rating current of fuse}$$

↳ Safety coefficient ↳ Ambient temperature

e.g.,

Condition : Normal operating current =1.5 A
 Ambient temperature 40 °C : Derating ratio \approx 0.95

$$\frac{1.5}{0.7 \times 0.95} < \text{rating current of fuse}$$

2.255 < rating current of fuse



Lead Free Thin Film Chip Fuse

Document No	TCFS-12OS051D
Issued date	2007/7/25
Page	10/15

■ Determination of the type of fuse

e.g.,

Condition :

- ◆ Calculating value = 2.255 A , 2.255A < rating current of fuse
- ◆ Normal operating voltage : DC 12 V
- ◆ Following bottom index-table :

Suggesting use CFS06V3T2R50 .

Part Designation	Marking	Rated Current	Rated Voltage
CFS12V6TR50	F	0.50A	63V
CFS12V6TR80	K	0.80A	63V
CFS12V6T1R0	L	1.00A	63V
CFS12V6T1R25	<u>M</u>	1.25A	63V
CFS12V61R50	P	1.50A	63V
CFS12V6T2R0	S	2.00A	63V
CFS12V3T2R50	T	2.50A	32V
CFS12V3T3R00	3	3.00A	32V
CFS12V2T4R0	W	4.00A	24V
CFS12V2T5R0	Y	5.00A	24V
CFS12V2T7R0	Z	7.00A	24V

■ Inrush current :

- ◆ Considering inrush waveform & calculate I^2t (A²s) value
- ◆ Choosing fuse's I^2t (A²s) value > calculate I^2t (A²s) value
- ◆ Considering Ratio of I^2t repeat numbers to blowing .
- ◆ Confrim with us

e.g., choosing 0603 Fuse

Condition :

1. Rectangular Wave , $I_p = 4$ A , $t = 1$ (ms) ,
Calculate $I_p^2t = 4^2 \times 1 \times 10^{-3}$ (A) = 0.016 (A²s)
2. Choosing CFS06V3T2R5 ($I^2t = 0.200$ (A²s)) \implies Page 12 index-table
3. Inrush shock : 100,000 times (≈ 0.35) \implies Inrush derating ratio

Calculating :

\curvearrowright Inrush 100,000 times

1. Choosing fuse's I^2t (A²s) value X Derating ratio > calculate I^2t (A²s) value
2. $0.200 \times 0.35 = 0.070$ (A²s)
4. $0.070 > 0.016$

TA-I TECHNOLOGY CO., LTD



Lead Free Thin Film Chip Fuse

Document No	TCFS-12OS051D
Issued date	2007/7/25
Page	11/15

The fuse is able to meet circuit 's application

TA-I FUSE I ² t (A ² s)	
Part Number	Typical I ² t (A ² s)
CFS12V6TR50	0.030
CFS12V6TR80	0.068
CFS12V6T1R0	0.098
CFS12V6T1R25	0.155
CFS12V6T1R50	0.236
CFS12V6T2R0	0.339
CFS12V3T2R50	0.605
CFS12V3T3R00	0.933
CFS12V2T4R0	1.537
CFS012V2T5R0	2.533
CFS12V2T7R0	5.684

Note*: Typical I²t value is measured at 10x-rated current, Application with surge over 10x-rated current.
Please confirm with us.

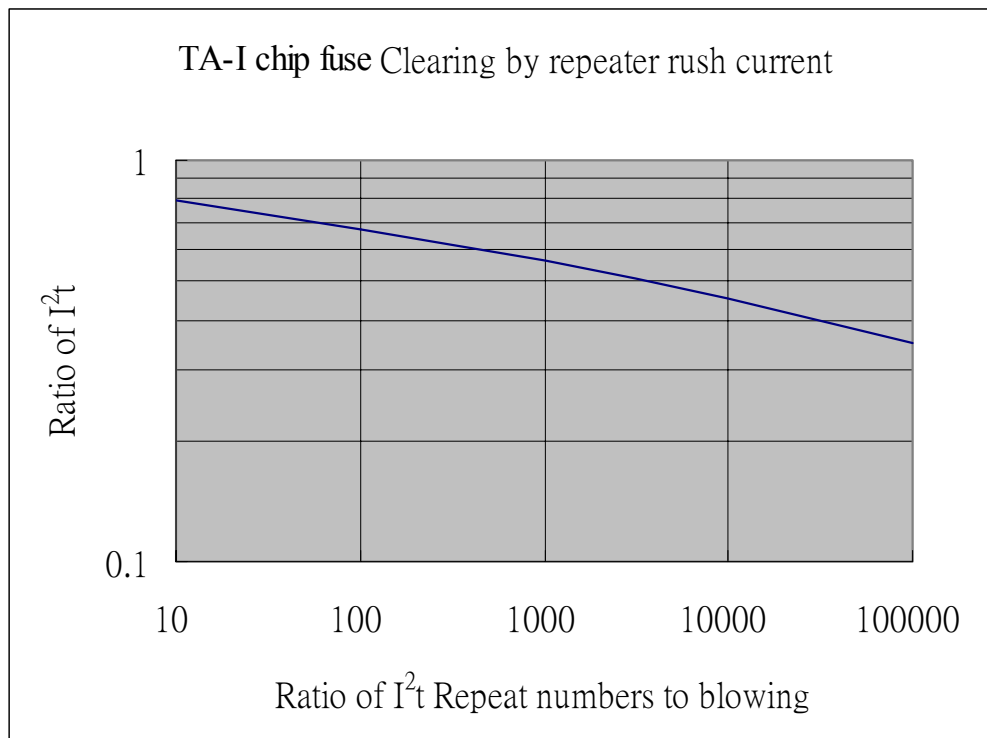



Inrush Waveform

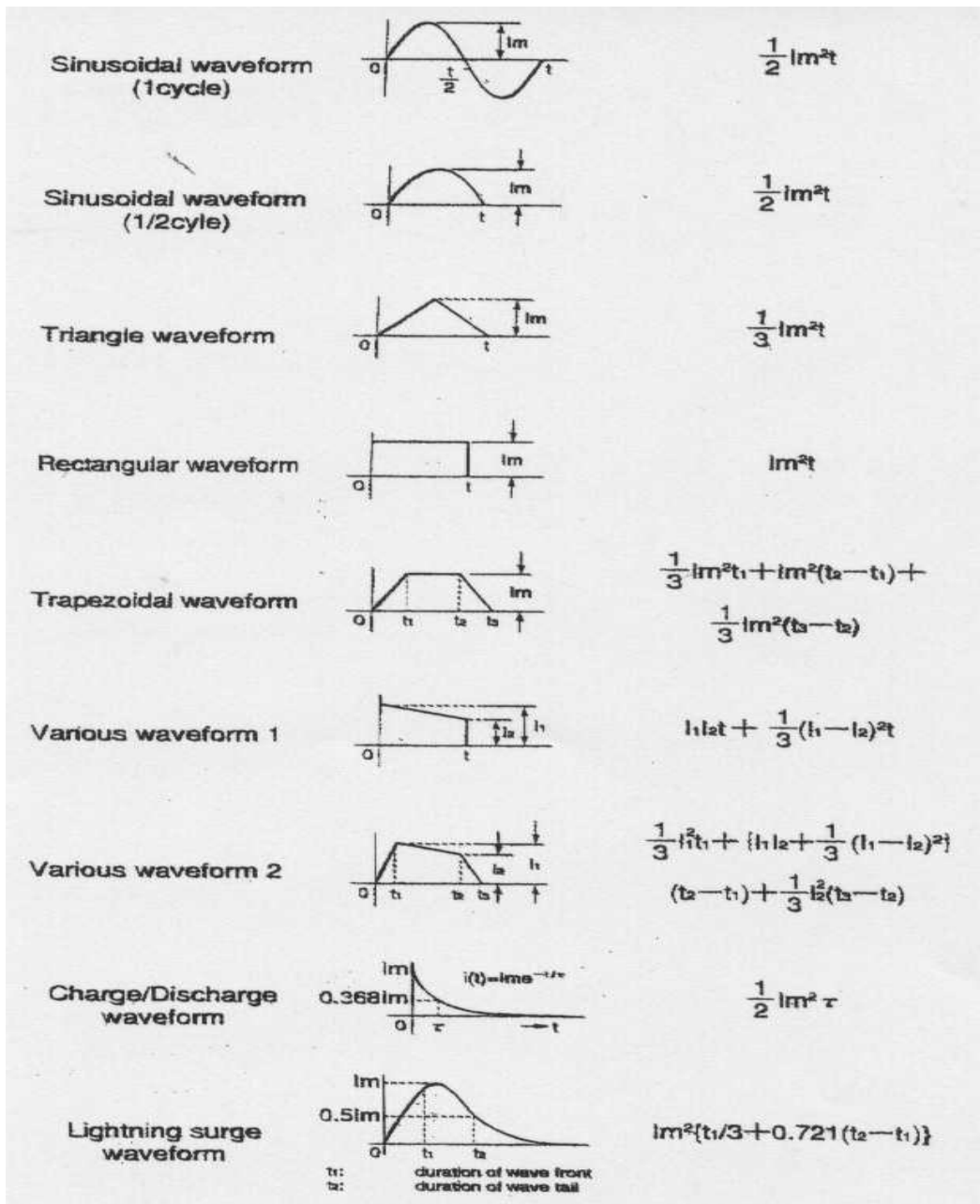



Lead Free Thin Film Chip Fuse

Document No	TCFS-12OS051D
Issued date	2007/7/25
Page	13/15

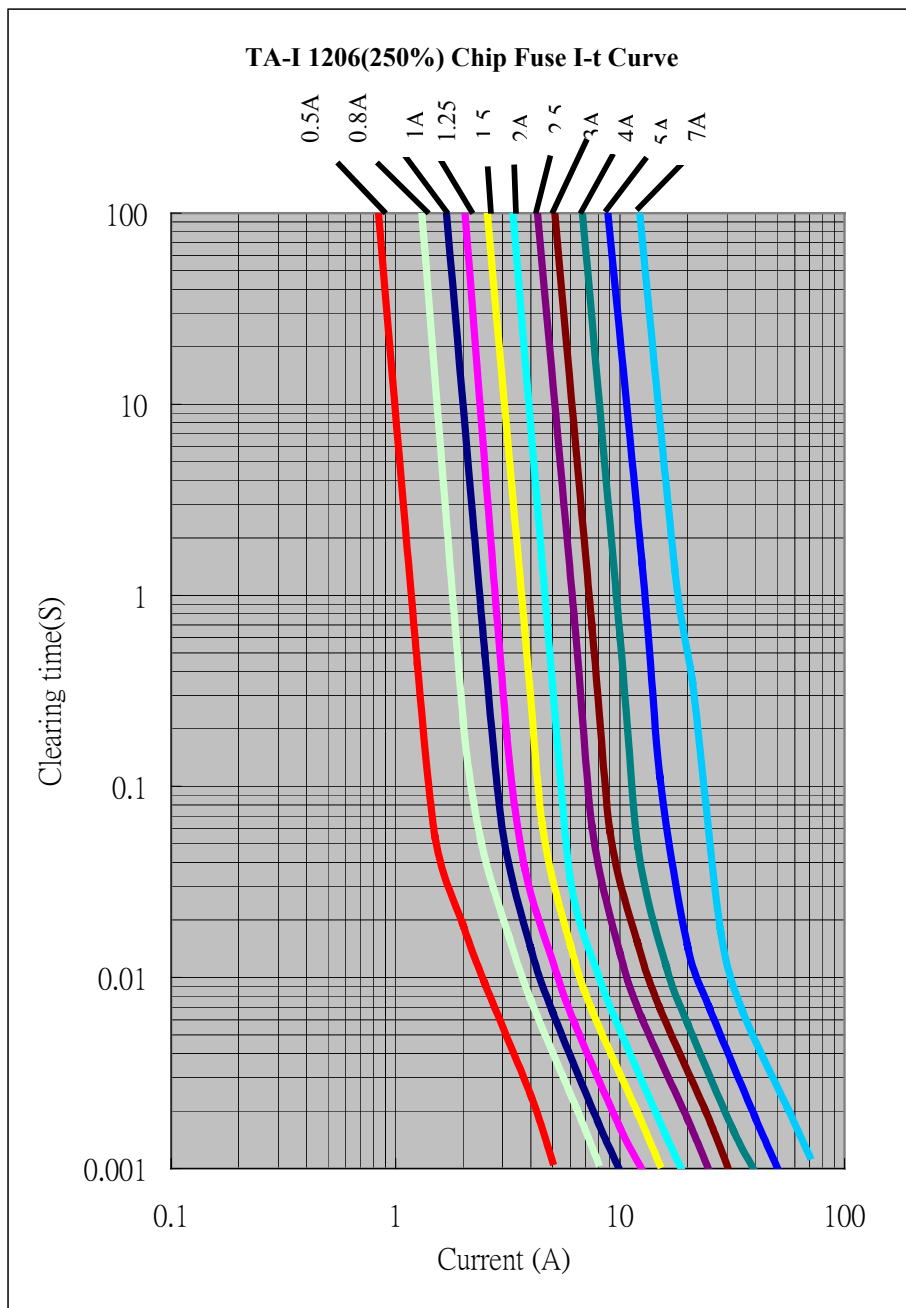



Lead Free Thin Film Chip Fuse

Document No	TCFS-12OS051D
Issued date	2007/7/25
Page	14/15

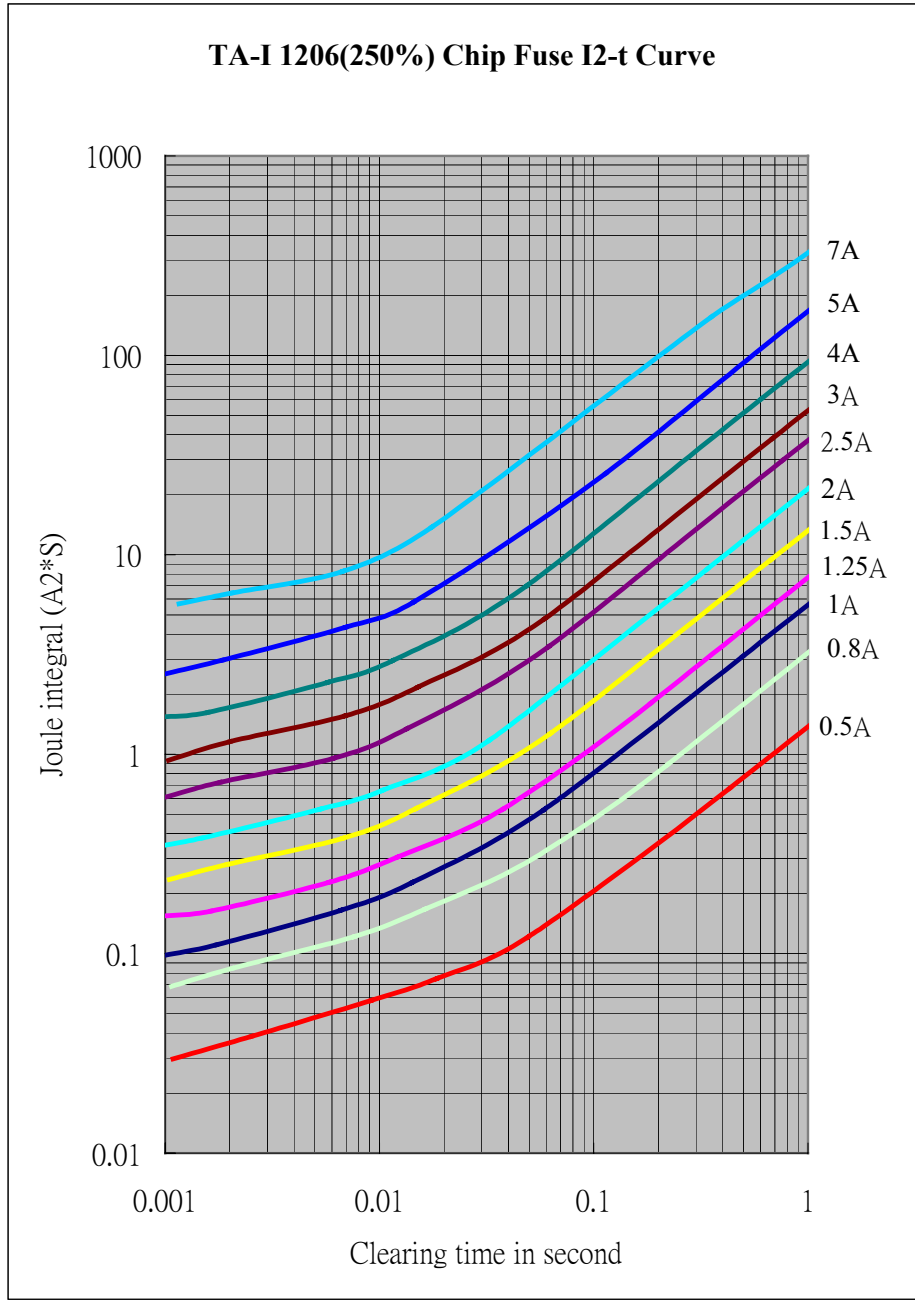

Downloaded from Elcodis.com electronic components distributor



Lead Free Thin Film Chip Fuse

Document No	TCFS-12OS051D
Issued date	2007/7/25
Page	15/15

Tset Circuit Borad

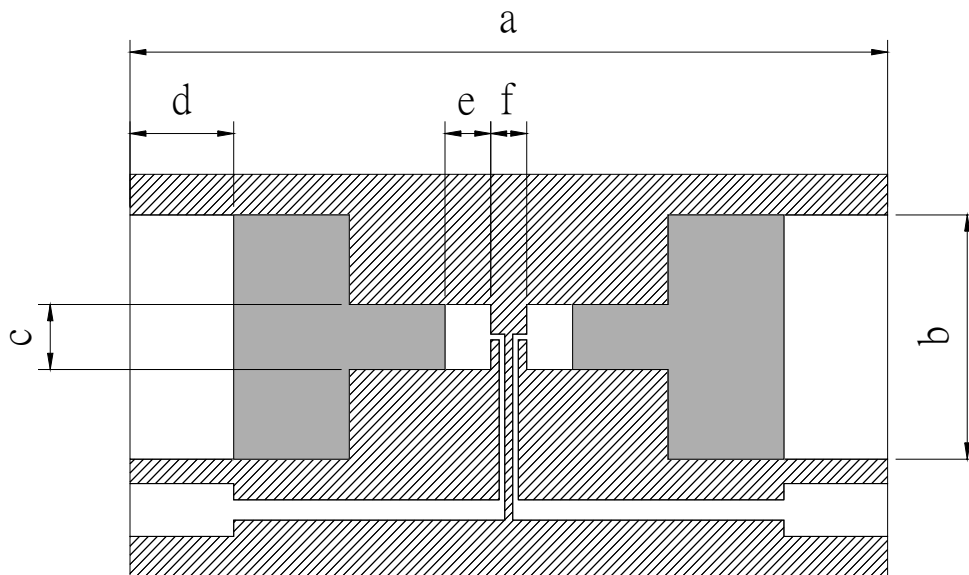

Type	a	b	c	d	e	f
CFS1206	19	6	2.4	2.6	1.9	1

Unit:mm