

---

## Features

- Digital Self-supervising Watchdog with Hysteresis
- One 150-mA Output Driver for Relay
- One High-side Driver for N-channel Power FET
- Positive and Negative Enable Output
- Positive and Negative Reset Output
- Over/Under-voltage Detection
- Relay and Power FET Outputs Protected Against Standard Transients and 55-V Load Dump



## 1. Description

The function of microcontrollers in safety-critical applications (e.g., anti-lock systems) needs to be monitored permanently. Usually, this task is accomplished by an independent watchdog timer. The monolithic IC U6813B, designed in bipolar technology and qualified according to the needs of the automotive industry, includes such a watchdog timer and provides additional features for added value. With the help of integrated driver stages, it is easy to control safety-related functions of a relay and of an N-channel power MOSFET in high-side applications. In case of a microcontroller malfunction or supply-voltage anomalies, the U6813B provides positive and negative reset and enable output signals. This flexibility guarantees a broad range of applications. The U6813B is based on of Atmel's fail-safe ICs U6808B and U6809B.



---

## Fail-safe IC with High-side and Relay Driver

---

## U6813B

Rev. 4543B-AUTO-10/05



Figure 1-1. Block Diagram

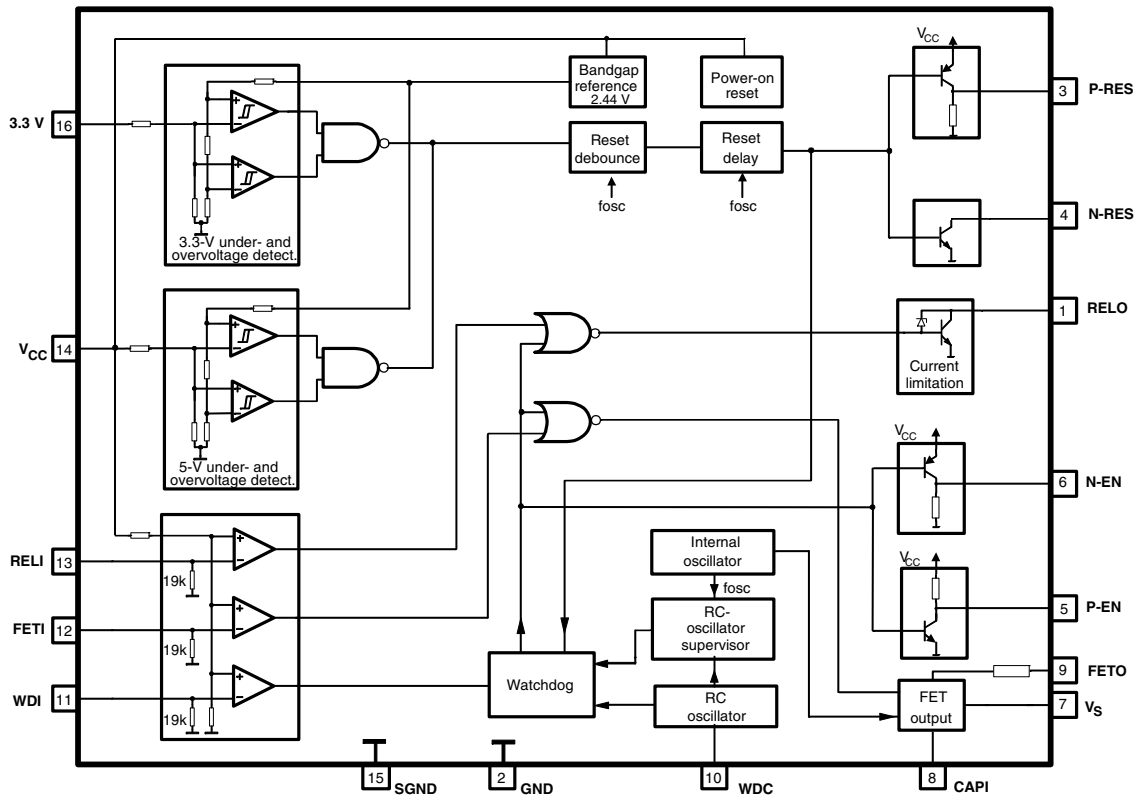

## 2. Pin Configuration

Figure 2-1. Pinning SO16

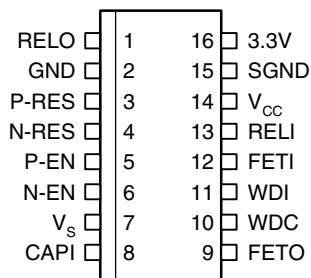

Table 2-1. Pin Description

Pin	Symbol	Description	Function	Type
1	RELO	Open-collector output driver	Fail-safe relay driver	Driver on: L
2	GND	Supply	General ground	
3	P-RES	Digital output	Positive reset signal	Reset: H
4	N-RES	Digital output	Negative reset signal	Reset: L
5	P-EN	Digital output	Positive enable signal	Enable: H
6	N-EN	Digital output	Negative enable signal	Enable: L
7	V <sub>S</sub>	Battery supply	Voltage for charge pump	
8	CAPI	Analog input	Input bootstrap capacitor	
9	FETO	Power FET output	High voltage for N-channel FET	
10	WDC	Analog input	External RC for watchdog timer	
11	WDI	Digital input	Watchdog trigger signal	Pulse sequence
12	FETI	Digital input	Activation of power FET	FET on: H
13	RELI	Digital input	Activation of relay driver	Driver on: H
14	V <sub>CC</sub>	Supply	5-V supply	
15	SGND	Supply	Sense ground, reference for V <sub>CC</sub> and 3.3 V	
16	3.3V	Analog input	3.3-V supply	

### 3. Fail-safe Functions

A fail-safe IC has to maintain its monitoring function even if there is a fault condition at one of the pins (e.g., short circuit), ensuring that a microcontroller system does not reach a “critical status”. A critical status means, for example, if the system is not able to switch off the relay or disable the power MOSFET, or if the system is not able to provide a signal to the microcontroller via ENABLE- and RESET-outputs in the case of a fault condition. The U6813B is designed to handle those fault conditions according to [Table 3-1](#) for a maximum of system safety.

**Table 3-1.** Truth Table

VCC	3.3V	WDI	RELI	FETI	RELO	FETO	N-RES	P-RES	P-EN <sup>(2)</sup>	N-EN <sup>(3)</sup>
ok	ok	ok	H	x	on	x	H	L	H	L
ok	ok	ok	L <sup>(1)</sup>	x	off	x	H	L	H	L
ok	ok	ok	x	H	x	on	H	L	H	L
ok	ok	ok	x	L <sup>(1)</sup>	x	off	H	L	H	L
ok	ok	wrong	x	x	off	off	H	L	L	H
x	wrong	x	x	x	off	off	L	H	L	H
wrong	x	x	x	x	off	off	L	H	L	H

- Notes:
1. default state at open input
  2. P-EN disable: low
  3. N-EN disable: high

### 4. Watchdog Description

**Figure 4-1.** Watchdog Block Diagram

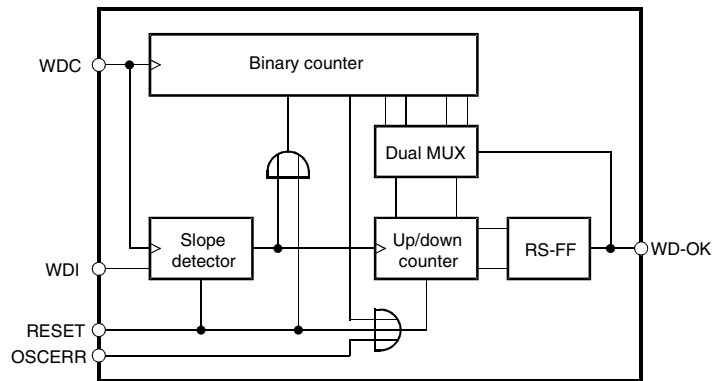

The microcontroller is monitored by a digital window watchdog which accepts an incoming trigger signal of a constant frequency for correct operation. The frequency of the trigger signal can be varied in a broad range as the watchdog’s time window is determined by external R/C components. The following description refers to the watchdog timing diagram with tolerances (see [Figure 4-2 on page 5](#)).

### 4.1 WDI Input (Pin 11)

The microcontroller has to provide a trigger signal with the frequency  $f_{WDI}$  which is fed to the WDI input. A positive edge of  $f_{WDI}$  detected by a slope detector resets the binary counter and clocks the up/down counter. The latter one counts only from 0 to 3 or reverse. Each correct trigger increments the up/down counter by 1, each wrong trigger decrements it by 1. As soon as the counter reaches status 3, the RS flip-flop is set; see Figure 4-3 (Watchdog state diagram). A missing incoming trigger signal is detected after 250 clocks of the internal watchdog frequency  $f_{RC}$  (see WD\_OK output) and resets the up/down counter directly.

### 4.2 WDC Input (Pin 10)

It is to be equipped by external R/C components. By means of an external R/C circuitry, the IC generates a time base (frequency  $f_{WDC}$ ) independent from the microcontroller. The watchdog's time window refers to a frequency of  $f_{WDC} = 100 \times f_{WDI}$ .

### 4.3 OSCERR Input

A smart watchdog has to ensure that internal problems with its own time base are detected and do not lead to an undesired status of the complete system. If the RC oscillator stops oscillating, a signal is fed to the OSCERR input after a time-out delay. It resets the up/down counter and disables the WD-OK output. Without this reset function, the watchdog would freeze its current status when  $f_{RC}$  stops.

### 4.4 RESET Input

During power-on and under/overvoltage detection, a reset signal is fed to this pin. It resets the watchdog timer and sets the initial state.

### 4.5 WD-OK Output

After the up/down counter has reached to status 3 (see Figure 4-3, Watchdog State Diagram), the RS flip-flop is set and the WD-OK output becomes logic "1". As WD-OK is directly connected to the enable pins, the open-collector output P-EN provides also logic "1" while a logic "0" is available at N-EN output. If on the other hand the up/down counter is decremented to "0", the RS flip-flop is reset, the WD-OK output and the P-EN output are logic "0" and N-EN output is logic "1". The WD-OK output also controls a dual MUX stage which shifts the time window by one clock after a successful trigger, thus forming a hysteresis to provide stable conditions for the evaluation of the trigger signal "good or false". The WD-OK signal is also reset in case the watchdog counter is not reset after 250 clocks (missing trigger signal).

Figure 4-2. Watchdog Timing Diagram with Tolerances

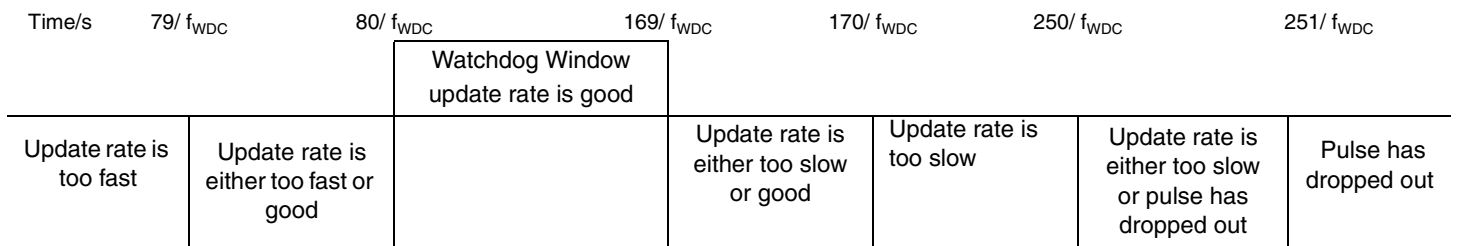

**Figure 4-3.** Watchdog State Diagram

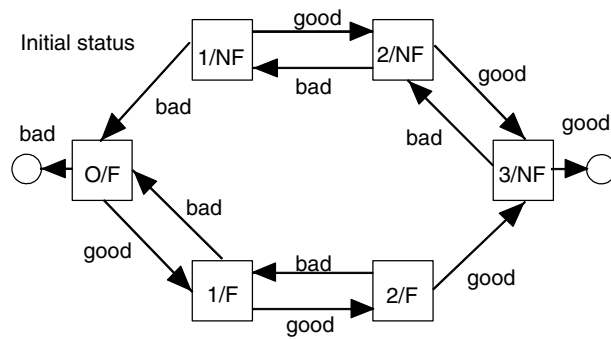

## 4.6 Explanation

In each block, the first character represents the state of the counter. The second notation indicates the fault status of the counter. A fault status is indicated by an “F” and a no-fault status is indicated by an “NF”. When the watchdog is powered up initially, the counter starts at the O/F block (initial state). “Good” indicates that a pulse has been received whose width resides within the timing window. “Bad” indicates that a pulse has been received whose width is either too short or too long.

## 4.7 Watchdog Window Calculation

Example with recommended values

$C_{osc} = 6.8 \text{ nF}$  (should be preferably 10%, NPO)

$R_{osc} = 36 \text{ k}\Omega$  (can be 5%,  $R_{osc} < 200 \text{ k}\Omega$  due to leakage current and humidity)

RC oscillator

$t_{WDC} \text{ (s)} = 10^{-3} [C_{osc} \text{ (nF)} [(0.00078 R_{osc} \text{ (k}\Omega) + 0.0005)]$

$f_{WDC} \text{ (Hz)} = 1/(t_{WDC})$

Watchdog WDI

$f_{WDI} \text{ (Hz)} = 0.01 f_{WDC}$

$t_{WDC} = 200 \mu\text{s} \rightarrow f_{WDC} = 5 \text{ kHz}$

$f_{WDI} = 50 \text{ Hz} \rightarrow t_{WDI} = 20 \text{ ms}$

WDI pulse width for fault detection after 3 pulses:

### Upper watchdog window

Minimum:  $169 / f_{WDC} = 33.8 \text{ ms} \rightarrow f_{WDC} / 169 = 29.55 \text{ Hz}$

Maximum:  $170 / f_{WDC} = 34 \text{ ms} \rightarrow f_{WDC} / 170 = 29.4 \text{ Hz}$

### Lower watchdog window

Minimum:  $79 / f_{WDC} = 15.8 \text{ ms} \rightarrow f_{WDC} / 79 = 63.3 \text{ Hz}$

Maximum:  $80 / f_{WDC} = 16 \text{ ms} \rightarrow f_{WDC} / 80 = 62.5 \text{ Hz}$

WDI dropouts for immediate fault detection:

Minimum:  $250 / f_{\text{WDC}} = 50.0 \text{ ms}$

Maximum:  $251 / f_{\text{WDC}} = 50.2 \text{ ms}$

Remarks to reset relay

The duration of the over- or undervoltage pulses determines the enable- and reset outputs. A pulse duration shorter than the debounce time has no effect on the outputs. A pulse longer than the debounce time results in the first reset delay. If a pulse appears during this delay, a second delay time is triggered. Therefore, the total reset delay time can be longer than specified in the data sheet.

## 5. Absolute Maximum Ratings

Stresses beyond those listed under “Absolute Maximum Ratings” may cause permanent damage to the device. This is a stress rating only and functional operation of the device at these or any other conditions beyond those indicated in the operational sections of this specification is not implied. Exposure to absolute maximum rating conditions for extended periods may affect device reliability.

Parameters	Symbol	Value	Unit
Supply voltage range	$V_S$	-0.2 to +26	V
Power dissipation $V_S = 5\text{V}; T_{\text{amb}} = -40^\circ\text{C}$ $V_S = 5\text{V}; T_{\text{amb}} = 125^\circ\text{C}$	$P_{\text{tot}}$ $P_{\text{tot}}$	250 150	mW mW
Junction temperature	$T_j$	150	$^\circ\text{C}$
Ambient temperature range	$T_{\text{amb}}$	-40 to +125	$^\circ\text{C}$
Storage temperature range	$T_{\text{stg}}$	-55 to +155	$^\circ\text{C}$

## 6. Thermal Resistance

Parameters	Symbol	Value	Unit
Junction ambient	$R_{\text{thJA}}$	110	K/W

## 7. Electrical Characteristics

$V_{CC} = 5V$ ,  $T_{amb} = -40$  to  $+125^{\circ}C$ ; reference pin is GND or SGND (over- and under-voltage detection);  
 $f_{intern} = 200$  kHz  $\pm 50\%$  /  $-45\%$ ,  $f_{WDC} = 5$  kHz  $\pm 10\%$ ;  $f_{WDI} = 50$  Hz, bootstrap capacitor  $C_{Boot} = 47$  nF at pin CAPI

No.	Parameters	Test Conditions	Pin	Symbol	Min.	Typ.	Max.	Unit	Type*
<b>1</b>	<b>Supply</b>								
1.1	Operation-voltage range		14	$V_{CC}$	4.5		5.5	V	D
1.2	Operation-voltage range of RESET outputs		14	$V_{CC}$	1.1		18.0	V	A
1.3	Current consumption	$V = 5.25V$ , Relay on $T_{amb} = -40^{\circ}C$ $T_{amb} = +125^{\circ}C$	14	$I_{CC}$ $I_{CC}$			15 10	mA mA	A
<b>2</b>	<b>Digital Input WDI</b>								
2.1	Detection low		11	$V_{WDI}$	-0.2		$0.3 \times V_{CC}$	V	D
2.2	Detection high		11	$V_{WDI}$	$0.7 \times V_{CC}$		$V_{CC} + 0.2V$	V	D
2.3	Internal pull-down resistor		11	$R_{INT11}$	10		40	k $\Omega$	A
2.4	Input current low	Input voltage = 0V	11	$I_{WDI}$	-5		5	$\mu A$	A
2.5	Input current high	Input voltage = 5V	11	$I_{WDI}$	100		550	$\mu A$	A
<b>3</b>	<b>Digital Input RELI</b>								
3.1	Detection low		13	$V_{RELI}$	-0.2		$0.3 \times V_{CC}$	V	D
3.2	Detection high		13	$V_{RELI}$	$0.7 \times V_{CC}$		$V_{CC} + 0.2V$	V	D
3.3	Internal pull-down resistor		13	$R_{INT13}$	10		40	k $\Omega$	A
3.4	Input current low	Input voltage = 0V	13	$I_{RELI}$	-5		5	$\mu A$	A
3.5	Input current high	Input voltage = 5V	13	$I_{RELI}$	100		550	$\mu A$	A
<b>4</b>	<b>Digital Input FETI</b>								
4.1	Detection low		12	$V_{FETI}$	-0.2		$0.3 \times V_{CC}$	V	A
4.2	Detection high		12	$V_{FETI}$	$0.7 \times V_{CC}$		$V_{CC} + 0.2V$	V	A
4.3	Internal pull-down resistor		12	$R_{INT12}$	10		40	k $\Omega$	A
4.4	Input current low	Input voltage = 0V	12	$I_{FETI}$	-5		5	$\mu A$	A
4.5	Input current high	Input voltage = 5V	12	$I_{FETI}$	100		550	$\mu A$	A

\*) Type means: A = 100% tested, B = 100% correlation tested, C = Characterized on samples, D = Design parameter

Note: 1. If  $V_S > 26$  V the current has to be limited at 5 mA by an external resistor.



## 7. Electrical Characteristics (Continued)

$V_{CC} = 5V$ ,  $T_{amb} = -40$  to  $+125^{\circ}C$ ; reference pin is GND or SGND (over- and under-voltage detection);  
 $f_{intern} = 200$  kHz  $\pm 50\%$ / $-45\%$ ,  $f_{WDC} = 5$  kHz  $\pm 10\%$ ;  $f_{WDI} = 50$  Hz, bootstrap capacitor  $C_{Boot} = 47$  nF at pin CAPI

No.	Parameters	Test Conditions	Pin	Symbol	Min.	Typ.	Max.	Unit	Type*
<b>5 Digital Output N-RES (Open Collector)</b>									
5.1	Saturation voltage low	$I_{reset} \leq 2.5$ mA	4	$V_{SAT4}$			0.5	V	A
5.2	Leakage current	at 5V, high state	4	$I_{LEAK4}$			0.5	$\mu A$	A
5.3	Reset debounce time (switch to low)	Over- or undervoltage	4	$t_{DEB4}$	120	320	500	$\mu s$	A
5.4	Reset delay (switch back to high)	Over- or undervoltage	4	$t_{DEL4}$		50		ms	A
<b>6 Digital Output P-RES (Internal Pull-down Resistor)</b>									
6.1	Saturation voltage high	$I_{reset} \leq 0.3$ mA	3	$V_{SAT3}$	$V_{CC} - 0.5V$		$V_{CC}$	V	A
6.2	Leakage current	at 0V, low state	3	$I_{LEAK3}$			0.5	$\mu A$	A
6.3	Internal pull-down resistor	at 5V	3	$R_{INT3}$	25		100	k $\Omega$	A
6.4	Reset debounce time (switch to low)	Over- or undervoltage	3	$t_{DEB3}$	120	320	500	$\mu s$	A
6.5	Reset delay (switch back to high)	Over- or undervoltage	3	$t_{DEL3}$		50		ms	A
<b>7 Digital Output N-EN (with Open Collector and Internal Pull-down Resistor)</b>									
7.1	Saturation voltage high	$I \leq 1$ mA	6	$V_{SAT6}$	$V_{CC} - 0.5V$		$V_{CC}$	V	A
7.2	Leakage current	at 0V, low state	6	$I_{LEAK6}$			0.5	$\mu A$	A
7.3	Internal pull-down resistor	at 5V	6	$R_{INT6}$	25		100	k $\Omega$	A
7.4	Enable debounce time (switch to low)	Over- or undervoltage	6	$t_{DEB6}$	120	320	500	$\mu s$	A
7.5	Enable delay (switch back to high)	Over- or undervoltage	6	$t_{DEL6}$		85		ms	A
<b>8 Digital Output P-EN (Internal Pull-up Resistor)</b>									
8.1	Saturation voltage high	$I \leq 3$ mA	5	$V_{SAT5}$			0.5	V	A
8.2	Leakage current	at 5V, high state	5	$I_{LEAK5}$			0.5	$\mu A$	A
8.3	Internal pull-up resistor	at 0V	5	$R_{INT5}$	12.5		50	k $\Omega$	A
8.4	Enable debounce time (switch to high)	Over- or undervoltage	5	$t_{DEB5}$	120	320	500	$\mu s$	A
8.5	Enable delay (switch back to low)	Over- or undervoltage	5	$t_{DEL5}$		85		ms	A

\* ) Type means: A = 100% tested, B = 100% correlation tested, C = Characterized on samples, D = Design parameter

Note: 1. If  $V_S > 26$  V the current has to be limited at 5 mA by an external resistor.

## 7. Electrical Characteristics (Continued)

$V_{CC} = 5V$ ,  $T_{amb} = -40$  to  $+125^{\circ}C$ ; reference pin is GND or SGND (over- and under-voltage detection);  
 $f_{intern} = 200$  kHz  $\pm 50\%$  /  $-45\%$ ,  $f_{WDC} = 5$  kHz  $\pm 10\%$ ;  $f_{WDI} = 50$  Hz, bootstrap capacitor  $C_{Boot} = 47$  nF at pin CAPI

No.	Parameters	Test Conditions	Pin	Symbol	Min.	Typ.	Max.	Unit	Type*
<b>9</b>	<b>Relay Driver (RELO)</b>								
9.1	Saturation voltage	$I \leq 150$ mA	1	$V_{SAT1}$	0.1		0.5	V	A
9.2	Current limitation		1	$I_{LIM}$	150		300	mA	A
9.3	Internal clamping voltage		1	$V_{CL}$	26		30	V	A
9.4	Turn-off energy		1		30			mJ	C
9.5	Leakage current	$V_{Batt} = 16V$ $V_{Batt} = 26V$ at $25^{\circ}C$	1	$I_{LEAK1}$ $I_{LEAK1}$			20 200	$\mu A$ $\mu A$	A
<b>10</b>	<b>Power-FET Output FETO (Maximum Load Capacitor at FET Gate 470 pF, Charge-pump Frequency 110 to 300 kHz)</b>								
10.1	Output voltage	$V_S = 9V$ to $15V$	9	$V_{OUT9}$	$V_S + 10V$		$V_S + 15V$	V	A
10.2	Operation range		7	$V_S$	9		20	V	A
10.3	Overvoltage shut-down		7	$V_S$	20		24	V	A
10.4	Internal clamping voltage		9	$V_{CL}$	26		30	V	A
10.5	On/off frequency		9	f			200	Hz	A
10.6	Maximum current	FETO	9	$I_{FETO}$	10			$\mu A$	A
<b>11</b>	<b>Battery Supply</b>								
11.1	Internal clamping voltage		7	$V_{CL}$	26		30	V	A
11.2	Clamping current capability <sup>(1)</sup>		7	$I_{VS}$	5			mA	A
11.3	Leakage current	at FETI = low	7	$I_{LEAVS}$			100	$\mu A$	A
<b>12</b>	<b>Reset and <math>V_{CC}</math> Control</b>								
12.1	Lower reset level	Reference SGND	14	$V_{CC}$	4.5		4.75	V	A
12.2	Upper reset level	Reference SGND	14	$V_{CC}$	5.25		5.5	V	A
12.3	Hysteresis		14	$V_{HYST14}$	25		100	mV	A
12.4	Reset debounce time		14	$t_{DEB}$	120	320	500	$\mu s$	A
12.5	Reset delay		14	$t_{DEL}$	20	50	80	ms	A
<b>13</b>	<b>Reset and 3.3V Control</b>								
13.1	Lower reset level	Reference SGND	16	$V_{3.3V}$	2.97		3.13	V	A
13.2	Upper reset level	Reference SGND	16	$V_{3.3V}$	3.47		3.63	V	A
13.3	Hysteresis		16	$V_{HYST16}$	15		70	mV	A
13.4	Reset debounce time		16	$t_{DEB16}$	120	320	500	$\mu s$	A
13.5	Reset delay		16	$t_{DEL16}$	20	50	80	ms	A
13.6	Current		16	$I_{3.3V}$			0.5	mA	C

\*) Type means: A = 100% tested, B = 100% correlation tested, C = Characterized on samples, D = Design parameter

Note: 1. If  $V_S > 26$  V the current has to be limited at 5 mA by an external resistor.

## 7. Electrical Characteristics (Continued)

$V_{CC} = 5V$ ,  $T_{amb} = -40$  to  $+125^{\circ}C$ ; reference pin is GND or SGND (over- and under-voltage detection);  
 $f_{intern} = 200$  kHz  $\pm 50\%$ / $-45\%$ ,  $f_{WDC} = 5$  kHz  $\pm 10\%$ ;  $f_{WDI} = 50$  Hz, bootstrap capacitor  $C_{Boot} = 47$  nF at pin CAPI

No.	Parameters	Test Conditions	Pin	Symbol	Min.	Typ.	Max.	Unit	Type*
<b>14</b>	<b>RC Oscillator WDC</b>								
14.1	Oscillator frequency	$R_{OSC} = 36$ k $\Omega$ $C_{OSC} = 6.8$ nF	10	$f_{WDC}$	4.5	5	5.5	kHz	A
<b>15</b>	<b>Watchdog Timing</b>								
15.1	Power-on-reset prolongation time			$t_{POR}$	34.3		103.1	ms	A
15.2	Detection time for RC-oscillator fault	$V_{CR} = \text{constant}$		$t_{RCerror}$	81.9		246	ms	A
15.3	Time interval for over/under-voltage detection			$t_{D,OUV}$	0.16		0.64	ms	A
15.4	Reaction time of reset output at over/under voltage			$t_{R,OUV}$	0.187		0.72	ms	A
15.5	Nominal frequency for WDI	$f_{RC} = 100 f_{WDI}$		$f_{WDI}$	10		65	Hz	D
15.6	Nominal frequency for WDC	$f_{WDI} = 1/100 f_{WDC}$		$f_{WDC}$	1		6.5	kHz	D
15.7	Minimum pulse duration for a guaranteed WDI input-pulse detection	$f_{WDC} = 5$ kHz		$t_{P,WDI}$	364			$\mu$ s	A
15.8	Frequency range for a correct WDI signal	$f_{WDC} = 5$ kHz		$f_{WDI}$	32.35		56.25	Hz	D
15.9	Number of incorrect WDI trigger counts for locking the outputs			$n_{lock}$		3			A
15.10	Number of correct WDI trigger counts for releasing the outputs			$n_{release}$		3			A
15.11	Detection time for a stucked WDI signal	$V_{WDI} = \text{constant}$ $f_{WDC} = 5$ kHz		$t_{WDIerror}$	49		51	ms	A
<b>16</b>	<b>Watchdog Timing Relative to <math>f_{WDC}</math></b>								
16.1	Minimum pulse duration for a guaranteed WDI input-pulse detection					2		cycles	A
16.2	Frequency range for a correct WDI signal				80		170	cycles	D
16.3	Hysteresis range at the WDI ok margins					1		cycle	A
16.4	Detection time for a stucked WDI signal (WDI dropout)	$V_{WDI} = \text{constant}$			250		251	cycles	A

\* ) Type means: A = 100% tested, B = 100% correlation tested, C = Characterized on samples, D = Design parameter

Note: 1. If  $V_S > 26$  V the current has to be limited at 5 mA by an external resistor.



## 8. Protection Versus Transient Voltages According to ISO TR 7637-1 Level 4 (Except Pulse 5)

Pulse	Voltage	Source Resistance <sup>(1)</sup>	Rise Time	Duration	Amount
1	-110V	10Ω	100V/s	2 ms	15.000
2	+110V	10Ω	100V/s	0.05 ms	15.000
3a	-160V	50Ω	30V/ns	0.1 μs	1h
3b	+150V	50Ω	20V/ns	0.1 μs	1h
5	55V	2Ω	10V/ms	250 ms	20

Note: 1. In the case of the relay driver, the coil resistance of  $R_{min} = 150\Omega$  has to be added to the source resistance.

## 9. Timing Diagrams

Figure 9-1. Watchdog in Too-fast Condition

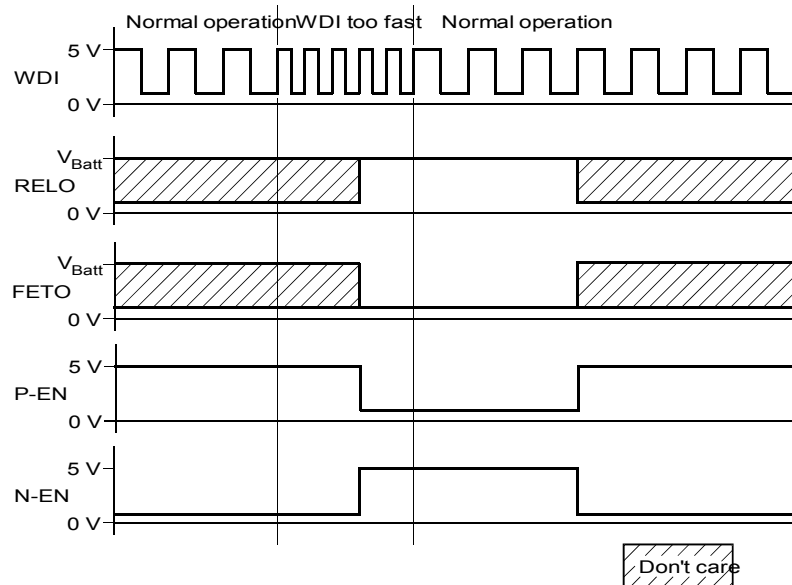

Figure 9-2. Watchdog in Too-slow Condition

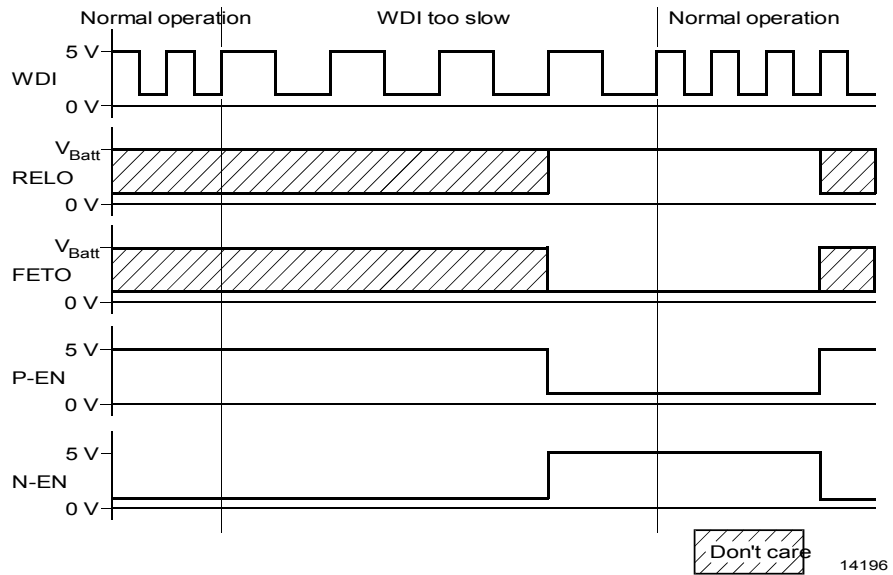
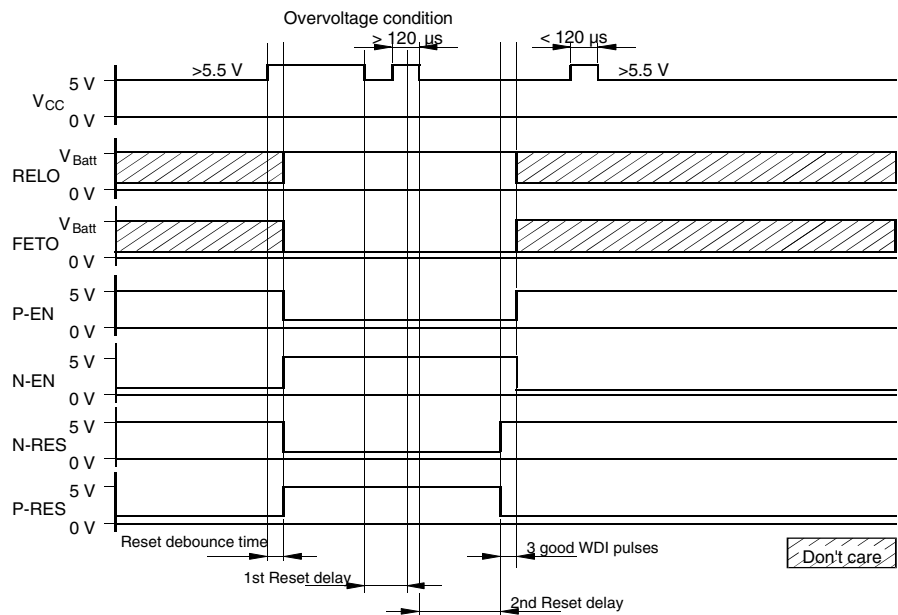
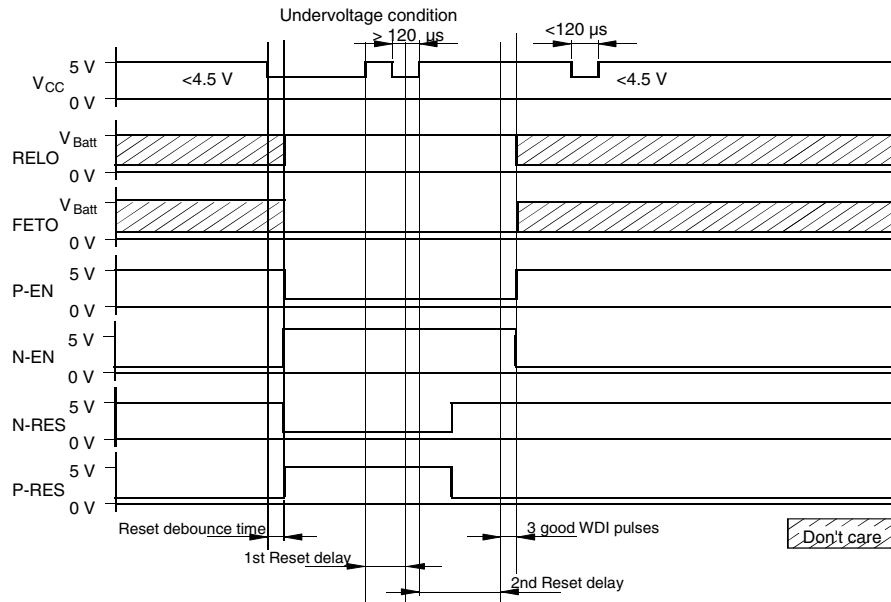

Figure 9-3. Overvoltage Condition



**Figure 9-4.** Undervoltage Condition



**Figure 9-5.** Application Circuit

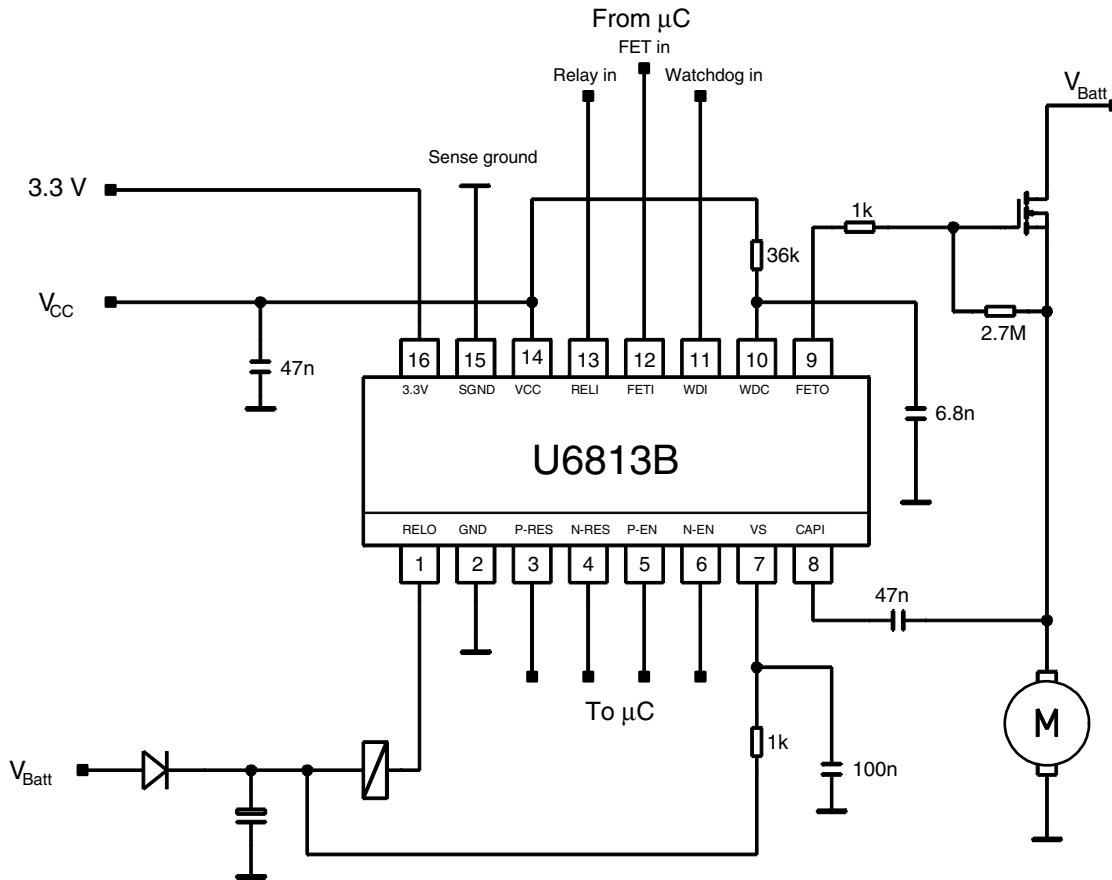

## 10. Ordering Information

Extended Type Number	Package	Remarks
U6813B-MFPG3Y	SO16	Taped and reeled, Pb-free

## 11. Package Information

Package SO16  
Dimensions in mm

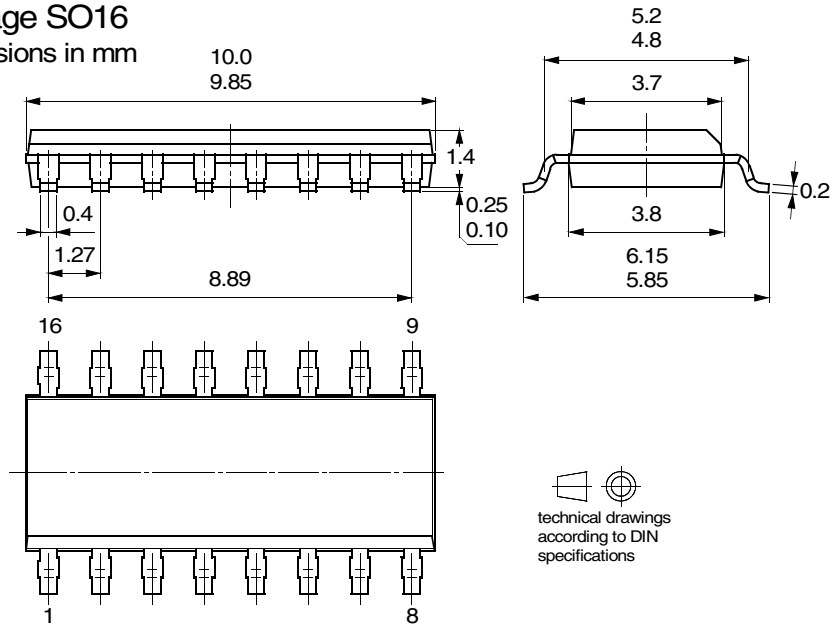

## 12. Revision History

Please note that the following page numbers referred to in this section refer to the specific revision mentioned, not to this document.

Revision No.	History
4543B-AUTO-10/05	<ul style="list-style-type: none"> <li>Put datasheet in a new template</li> <li>Pb-free logo on page 1 added</li> <li>New heading rows on Table "Absolute Maximum Ratings" on page 7 added</li> <li>Table "Ordering Information" on page 15 changed</li> </ul>



## Atmel Corporation

2325 Orchard Parkway  
San Jose, CA 95131, USA  
Tel: 1(408) 441-0311  
Fax: 1(408) 487-2600

## Regional Headquarters

### Europe

Atmel Sarl  
Route des Arsenaux 41  
Case Postale 80  
CH-1705 Fribourg  
Switzerland  
Tel: (41) 26-426-5555  
Fax: (41) 26-426-5500

### Asia

Room 1219  
Chinachem Golden Plaza  
77 Mody Road Tsimshatsui  
East Kowloon  
Hong Kong  
Tel: (852) 2721-9778  
Fax: (852) 2722-1369

### Japan

9F, Tonetsu Shinkawa Bldg.  
1-24-8 Shinkawa  
Chuo-ku, Tokyo 104-0033  
Japan  
Tel: (81) 3-3523-3551  
Fax: (81) 3-3523-7581

## Atmel Operations

### Memory

2325 Orchard Parkway  
San Jose, CA 95131, USA  
Tel: 1(408) 441-0311  
Fax: 1(408) 436-4314

### Microcontrollers

2325 Orchard Parkway  
San Jose, CA 95131, USA  
Tel: 1(408) 441-0311  
Fax: 1(408) 436-4314

La Chantrerie  
BP 70602  
44306 Nantes Cedex 3, France  
Tel: (33) 2-40-18-18-18  
Fax: (33) 2-40-18-19-60

### ASIC/ASSP/Smart Cards

Zone Industrielle  
13106 Rousset Cedex, France  
Tel: (33) 4-42-53-60-00  
Fax: (33) 4-42-53-60-01

1150 East Cheyenne Mtn. Blvd.  
Colorado Springs, CO 80906, USA  
Tel: 1(719) 576-3300  
Fax: 1(719) 540-1759

Scottish Enterprise Technology Park  
Maxwell Building  
East Kilbride G75 0QR, Scotland  
Tel: (44) 1355-803-000  
Fax: (44) 1355-242-743

### RF/Automotive

Theresienstrasse 2  
Postfach 3535  
74025 Heilbronn, Germany  
Tel: (49) 71-31-67-0  
Fax: (49) 71-31-67-2340

1150 East Cheyenne Mtn. Blvd.  
Colorado Springs, CO 80906, USA  
Tel: 1(719) 576-3300  
Fax: 1(719) 540-1759

### Biometrics/Imaging/Hi-Rel MPU/ High Speed Converters/RF Datacom

Avenue de Rochepleine  
BP 123  
38521 Saint-Egreve Cedex, France  
Tel: (33) 4-76-58-30-00  
Fax: (33) 4-76-58-34-80

---

### Literature Requests

[www.atmel.com/literature](http://www.atmel.com/literature)

**Disclaimer:** The information in this document is provided in connection with Atmel products. No license, express or implied, by estoppel or otherwise, to any intellectual property right is granted by this document or in connection with the sale of Atmel products. **EXCEPT AS SET FORTH IN ATMEL'S TERMS AND CONDITIONS OF SALE LOCATED ON ATMEL'S WEB SITE, ATMEL ASSUMES NO LIABILITY WHATSOEVER AND DISCLAIMS ANY EXPRESS, IMPLIED OR STATUTORY WARRANTY RELATING TO ITS PRODUCTS INCLUDING, BUT NOT LIMITED TO, THE IMPLIED WARRANTY OF MERCHANTABILITY, FITNESS FOR A PARTICULAR PURPOSE, OR NON-INFRINGEMENT. IN NO EVENT SHALL ATMEL BE LIABLE FOR ANY DIRECT, INDIRECT, CONSEQUENTIAL, PUNITIVE, SPECIAL OR INCIDENTAL DAMAGES (INCLUDING, WITHOUT LIMITATION, DAMAGES FOR LOSS OF PROFITS, BUSINESS INTERRUPTION, OR LOSS OF INFORMATION) ARISING OUT OF THE USE OR INABILITY TO USE THIS DOCUMENT, EVEN IF ATMEL HAS BEEN ADVISED OF THE POSSIBILITY OF SUCH DAMAGES.** Atmel makes no representations or warranties with respect to the accuracy or completeness of the contents of this document and reserves the right to make changes to specifications and product descriptions at any time without notice. Atmel does not make any commitment to update the information contained herein. Unless specifically provided otherwise, Atmel products are not suitable for, and shall not be used in, automotive applications. Atmel's products are not intended, authorized, or warranted for use as components in applications intended to support or sustain life.

© Atmel Corporation 2005. All rights reserved. Atmel®, logo and combinations thereof, Everywhere You Are® and others, are registered trademarks or trademarks of Atmel Corporation or its subsidiaries. Other terms and product names may be trademarks of others.



Printed on recycled paper.

4543B-AUTO-10/05