

FEATURES

- Ideal for printed circuit boards.
- Low forward voltage drop, high current capability.
- The Plastic material has Underwriters Laboratory Flammability Classification 94V-0.
- Rating to 1000V RRV.

MAXIMUM RATING (Ta=25 °C)

CHARACTERISTIC	SYMBOL	RATING	UNIT
Repetitive peak reverse voltage	V_{RRM}	600	V
RMS voltage	V_{RMS}	420	V
DC blocking voltage	V_{DC}	600	V
Average forward rectified output current (Tc=110 °C)	$I_{F(AV)}$	6	A
Peak forward surge current	I_{FSM}	170	A
Rating for fusing (t<8.3ms)	I ² t	120	A ² sec
Operating Junction	Tj	-55~150	°C
Storage Temperature Range	Tstg	-55~150	°C

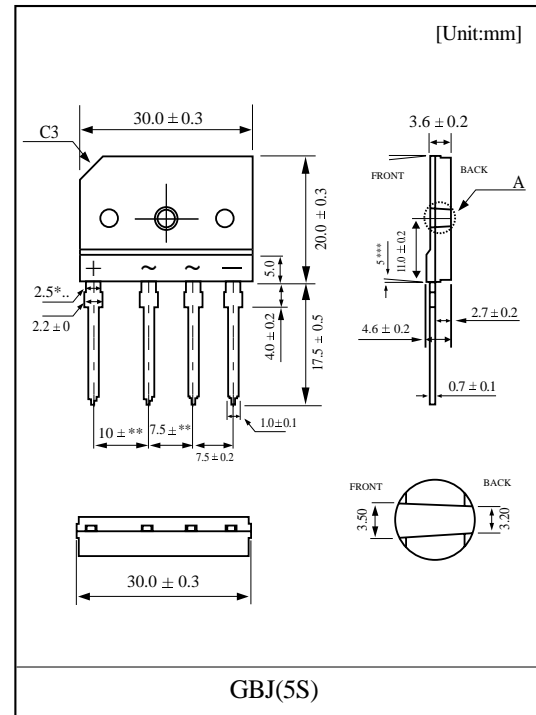

Marking

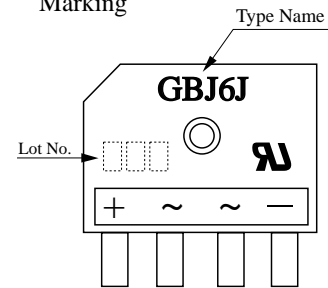

ELECTRICAL CHARACTERISTICS (Ta=25 °C)

CHARACTERISTIC	SYMBOL	CONDITION	MIN	TYP	MAX	UNIT
Forward voltage	V_F	$I_F=3.0A$	-	-	1.0	V
Leakage current	I_R	$V_R=600V$	-	-	5	μA
			-	-	500	
Junction capacitance	C_J	$V_R=4.0V, f=1.0MHz$	-	55	-	pF
Thermal resistance (Note1)	$R_{th}(C)$	Junction to case	-	-	1.8	°C/W

Note 1) Device mounted on 75mm × 75mm × 1.6mm Cu plate heatsink.

Fig.1 Forward Current Derating Curve

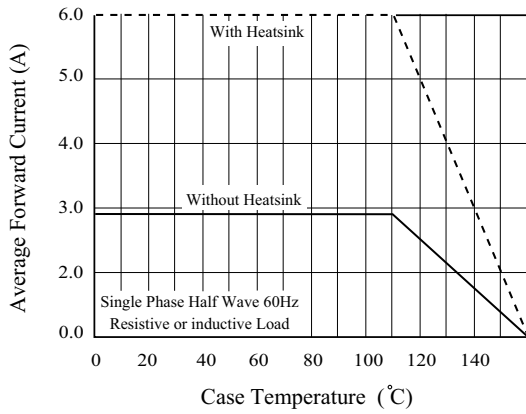

Fig.2 Maximum Non-Repetitive Surge Current

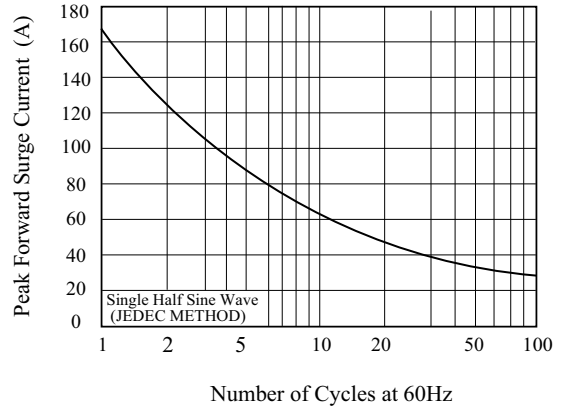

Fig.3 Typical Junction Capacitance

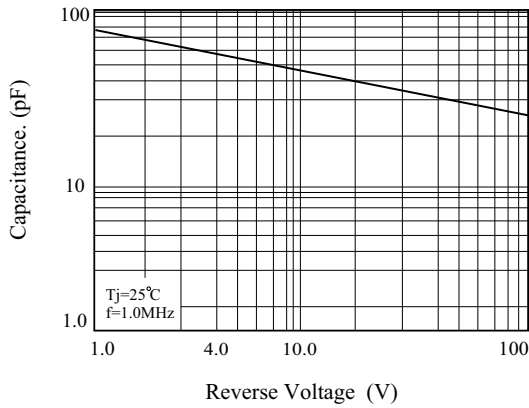

Fig.4 Typical Forward Characteristics

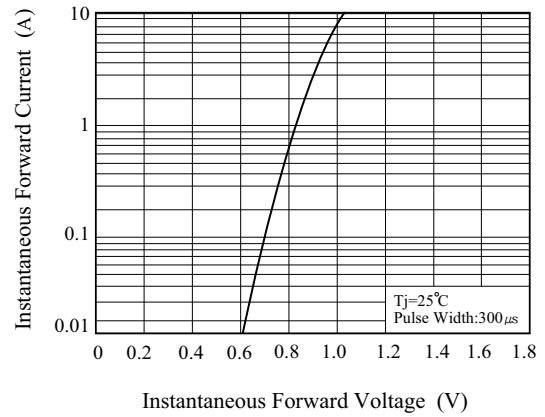

Fig.5 Typical Reverse Characteristics

