

GBJ1502-G Thru. GBJ1508-G

Reverse Voltage: 200 to 800V

RoHS Device



Features

- Plastic package has underwriters laboratory Flammability classification 94V-0.
- Glass passivated chip junction.
- High case dielectric with standing voltage of 2500 VRMS.
- High surge current capability.
- Ideal for printed circuit boards.
- High temperature soldering guaranteed: 260°C/10sec, 0.375" (9.5mm) lead length, 5lbs. (2.3kg) tension.

Mechanical Data

- Case: 5S Molded Plastic body
- Terminal: Plated leads solderable per MIL-STD-750, method 2026.
- Mounting position : Any (Note 3).
- Mounting torque: 8 in-lbs max.
- Weight: 0.26 ounce, 7.0 grams.

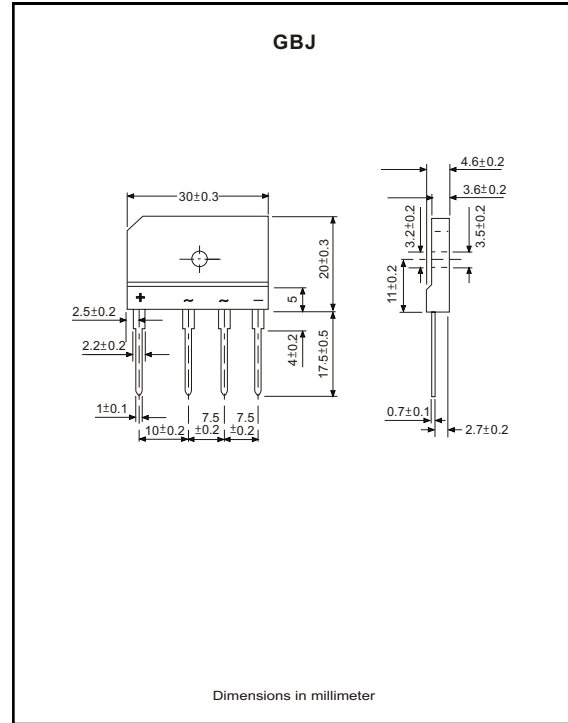

Maximum ratings and electrical characteristics

Rating at 25°C ambient temperature unless otherwise specified.

Parameter	Symbol	GBJ1502-G	GBJ1504-G	GBJ1506-G	GBJ1508-G	Unit
Maximum repetitive peak reverse voltage	V_{RRM}	200	400	600	800	V
Maximum RMS voltage	V_{RMS}	140	280	420	560	V
Maximum DC blocking voltage	V_{DC}	200	400	600	800	V
Maximum average forward output current @ $T_C=107^\circ\text{C}$ @ $T_A=25^\circ\text{C}$	$I_{F(AV)}$	15 3.5				A
Peak forward surge current, 8.3ms single half sine-wave superimposed on rated load (JEDEC method)	I_{FSM}	240				A
Rating for fusing ($t < 8.3\text{ms}$)	I^2t	60				A^2sec
Maximum instantaneous forward voltage drop per element at 7.5A DC	V_F	1.05				V
Maximum reverse current at rated DC blocking voltage $T_A=25^\circ\text{C}$ $T_A=125^\circ\text{C}$	I_R	10 250				μA
Typical thermal resistance per leg	$R_{\theta JA}$	22				$^\circ\text{C/W}$
Operating and storage temperature range	T_J, T_{STG}	-55 ~ +150				$^\circ\text{C}$

Note:

1. Unit case mounted on Al plate heatsink.
2. Unit mounted on P.C.B. with 0.5×0.5" (12×12mm) copper pads and 0.375" (9.5mm) lead length.
3. Recommended mounting position is to bolt down on heatsink with silicon thermal compound for maximum heat transfer with #6 screws.

Rating and Characteristics Curves (GBJ1502-G Thru. GBJ1508-G)

Fig. 1 Output Rectified Current Derating Curve

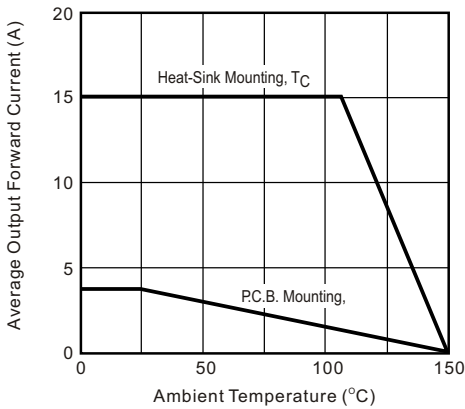

Fig. 2 Max. Non-repetitive Forward Surge Current Per Leg

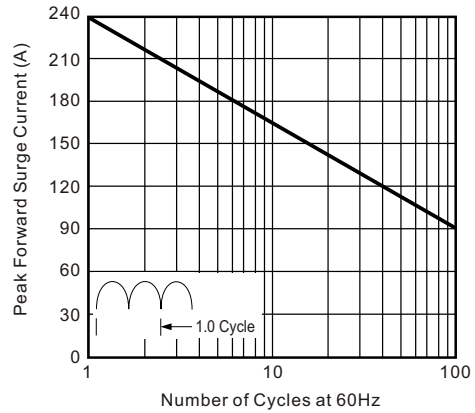

Fig. 3 Typical Forward Characteristics Per Leg

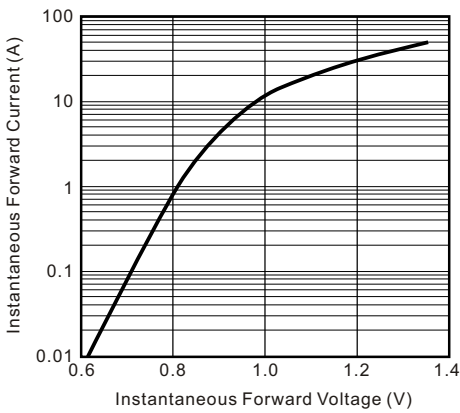

Fig. 4 Typical Reverse Characteristics Per Leg

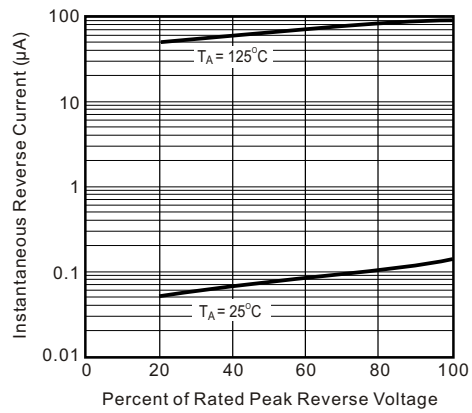

Fig. 5 Typical Junction Capacitance Per Leg

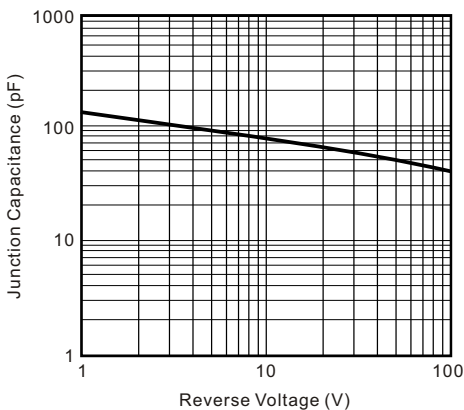

Fig. 6 Typical Transient Thermal Impedance

