

## SS520 Series Dual Hall-effect Digital Position Sensors with speed & direction outputs

Series SS520



### FEATURES

- Single miniature plastic package includes two separate Hall sensors
- Frequency signal for speed output
- Logic level (High or Low) signal for direction output
- Temperature compensated magnetics
- Functionality of two discrete Hall sensors and logic circuitry outputs
- Symmetry of operate/release points about zero gauss (bipolar/latching)
- Low current consumption
- Wide operating voltage range

### TYPICAL APPLICATIONS

- Anti-pinch electric motor control systems for power windows, power seats (headrest), power sliding doors, sunroofs, garage door openers.
- Magnetic encoding for electronic steering systems
- Motion control systems for pulleys and belts
- Position and velocity detection
- Fan control
- Rotating shaft monitoring
- Linear displacement sensing (using a magnetic strip of alternating poles)

### GENERAL DESCRIPTION

The Speed & Direction Hall-effect sensor has two distinct Hall sensing elements precisely located 1.4 mm apart on a single integrated circuit chip, which is then encapsulated in a thermoset molding material. Two active Hall latches provide indication of the speed and direction of a magnetic gradient across the face of the package, such as the gradient from a rotating ring magnet. The small, 4-pin SOT89 style package surface mounts on PC boards and flexible circuits.

Built-in temperature compensation is optimized to match the temperature coefficient of low cost magnets and track their performance over temperature.

Latching magnetics are standard for reliable operation.

A novel regulator circuit provides extremely stable operation with supply voltages as low as 3.4 Vdc and as high as 24 Vdc. A typical room temperature current consumption of 7.5 mA helps conserve power in battery operation. SS520 series sensors can use existing power supply sources in most applications, and can be directly interfaced with many electronic components without buffering or compensation circuitry.

#### CAUTION

##### WAVE SOLDER DAMAGE

DO NOT wave solder this product.

Wave soldering may negatively affect the sensor performance and reliability.

Subjecting the sensor to wave soldering will void Honeywell's warranty.

**Failure to comply with these instructions may result in product damage.**

#### NOTICE

Interruption of power to a latching device may cause the output to change state when power is restored. If a magnetic field of sufficient strength is present, the sensor output will be in the condition dictated by the magnetic field.

# Hall-effect Digital Speed & Direction Sensor

Series SS520

Product Listing	SS526DT
Package Quantity/Type	Available in 1,000/Tape and Reel
Package Style	SS5 Surface Mount
Supply Voltage	-0.5 Vdc to 30 Vdc
Supply Current at 25 °C	7.5 mA typ.
Output Type	Dual Sink (speed & direction)
Output Current	5 mA max. each output
Magnetic Actuation Type	Bipolar Latch
Operate Point at 25 °C	130 Gauss [13.0 mT] typ.
Release Point at 25 °C	-130 Gauss [-13.0 mT] typ.
Operating Temperature Range	-40 °C to 125 °C [-40 °F to 257 °F]
Differential min.	260 Gauss [26.0 mT] typ.
Output Voltage	0.4(V) max.
Switching Time Rise (10 % to 90 %)	1.5 μs max.
Switching Time Fall (90 % to 10 %)	1.5 μs max.
Leakage Current	10 μA max.
Operating Frequency (f)	> 1000 Hz min.
Availability	Global

## INTERFACING DIAGRAMS

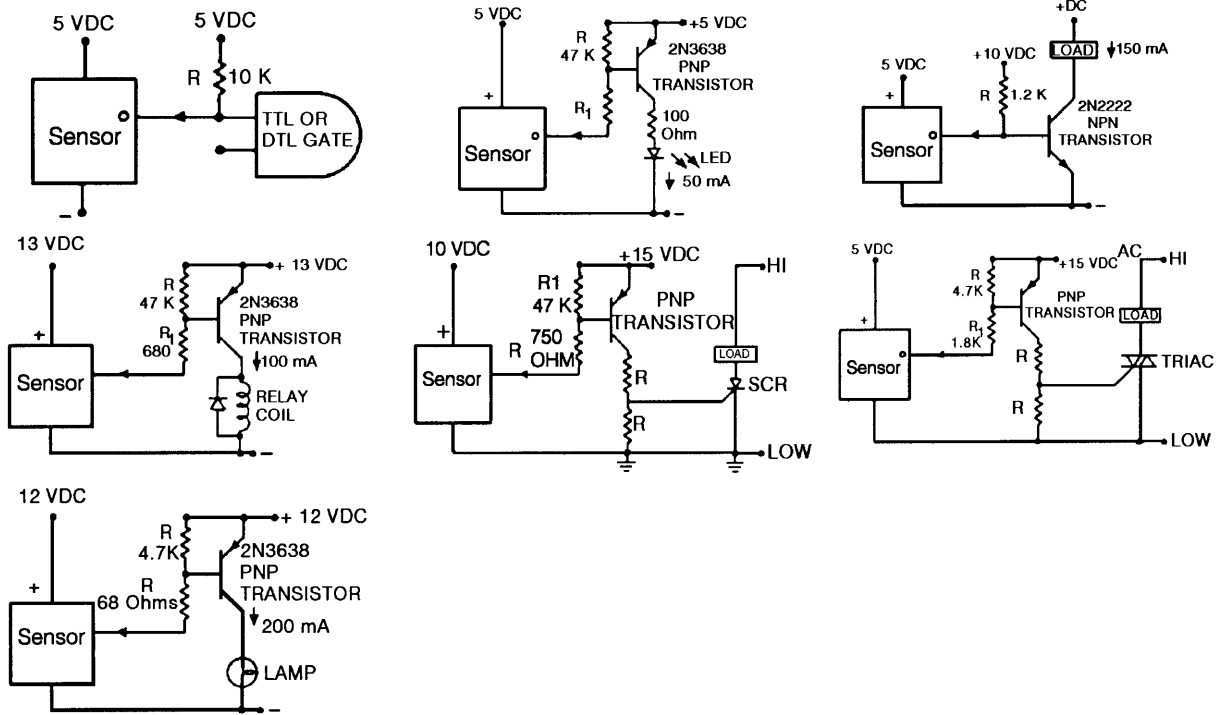

## OUTPUT TIMING DIAGRAM

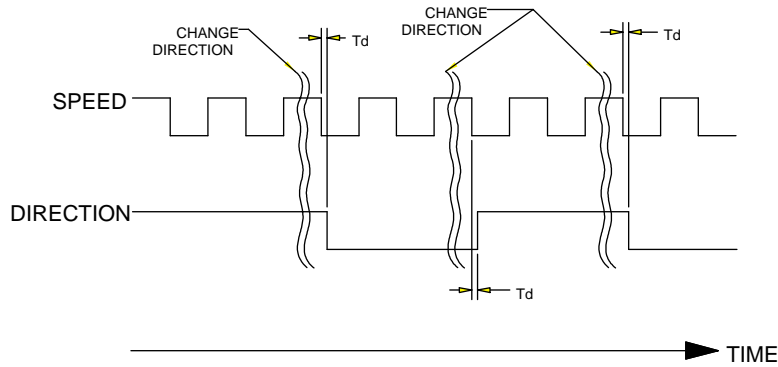

## DIMENSIONS mm [in] (For reference only)

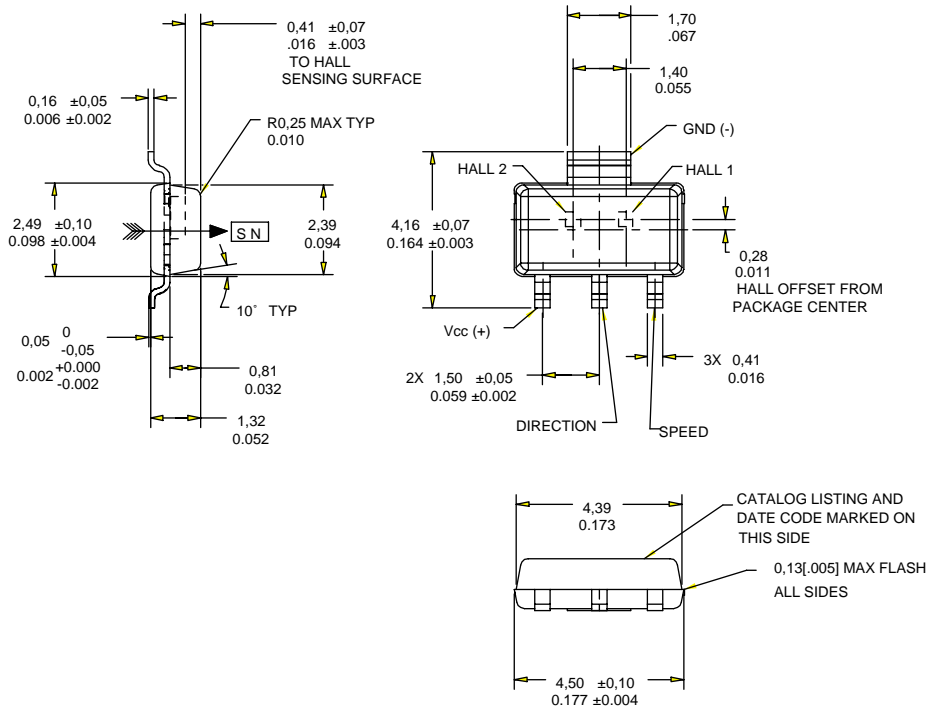

**TAPE AND REEL DIMENSIONS mm [in] (For reference only)**

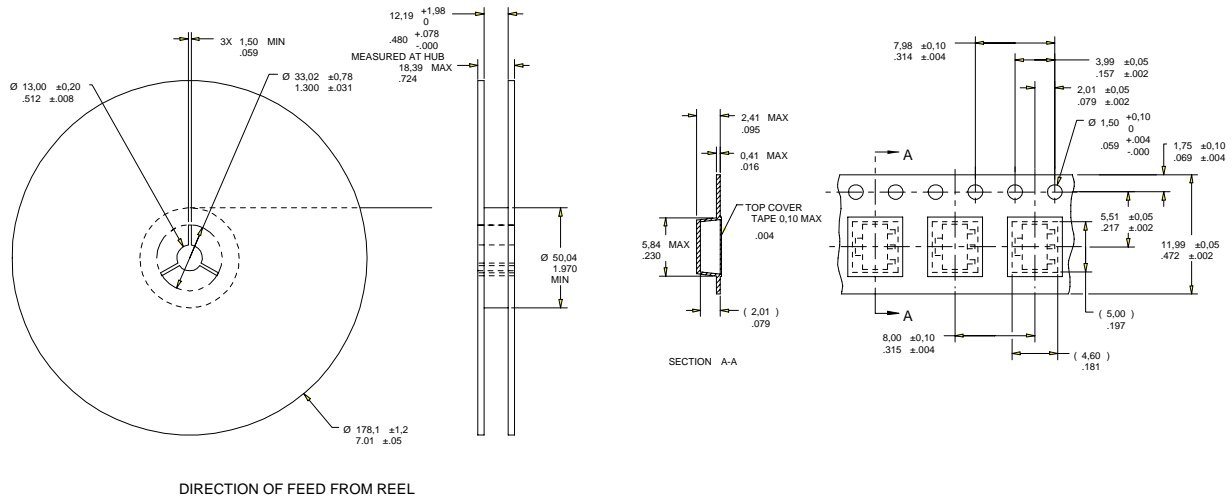

**WARRANTY/REMEDY**

Honeywell warrants goods of its manufacture as being free of defective materials and faulty workmanship. Contact your local sales office for warranty information. If warranted goods are returned to Honeywell during the period of coverage, Honeywell will repair or replace without charge those items it finds defective. The foregoing is Buyer's sole remedy and is **in lieu of all other warranties, expressed or implied, including those of merchantability and fitness for a particular purpose.**

Specifications may change without notice. The information we supply is believed to be accurate and reliable as of this printing. However, we assume no responsibility for its use.

While we provide application assistance personally, through our literature and the Honeywell web site, it is up to the customer to determine the suitability of the product in the application.

For application assistance, current specifications, or name of the nearest Authorized Distributor, check the Honeywell web site or call:  
 1-800-537-6945 USA  
 1-800-737-3360 Canada  
 1-815-235-6847 International  
**FAX**  
 1-815-235-6545 USA  
**INTERNET**  
[www.honeywell.com/sensing](http://www.honeywell.com/sensing)  
[info.sc@honeywell.com](mailto:info.sc@honeywell.com)

**WARNING**

**PERSONAL INJURY**

DO NOT USE these products as safety or emergency stop devices, or in any other application where failure of the product could result in personal injury.

**Failure to comply with these instructions could result in death or serious injury.**

**WARNING**

**PERSONAL INJURY**

- The information presented in this product sheet is for reference only.
- DO NOT USE this document as system installation information.
- Complete installation, operation, and maintenance information is provided in the instructions supplied with each product.

**Failure to comply with these instructions could result in death or serious injury.**

**Honeywell**

Sensing and Control  
 Honeywell  
 11 West Spring Street  
 Freeport, Illinois 61032

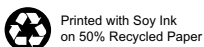

007433-1-EN IL50 GLO 1200 Printed in USA

[www.honeywell.com/sensing](http://www.honeywell.com/sensing)