

BZX384C Series

ZENER DIODES

FEATURES :

- * Silicon Planar Power Zener Diodes
- * The Zener voltages are graded according to the international E 24 standard.
- * Standard Zener voltage tolerance is $\pm 5\%$.
Replace "C" with "B" for $\pm 2\%$ tolerance.
- * Pb / RoHS Free

MECHANICAL DATA

- * Case : SOD-323 Plastic Package
- * Weight : 0.004 gram

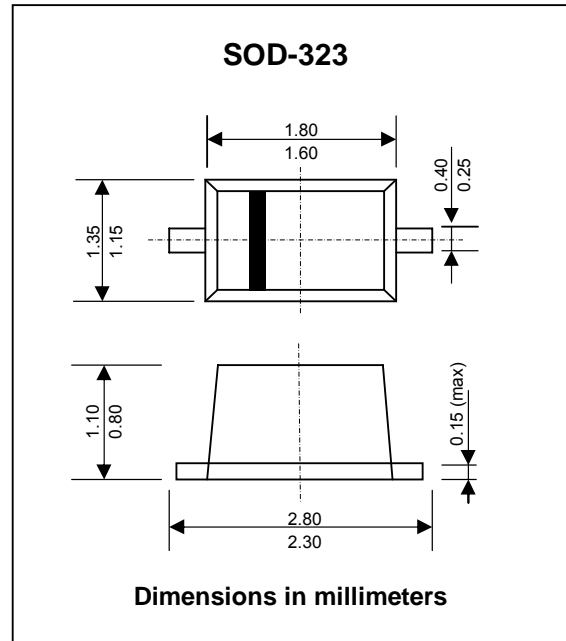

Maximum Ratings and Thermal Characteristics (Ta 25 °C unless otherwise noted)

Parameter	Symbol	Value	Unit
Zener Current	I_{ZM}	250	mA
Power Dissipation at $T_{amp} = 25\text{ °C}$	P_{tot}	200 ⁽¹⁾	Mw
Thermal Resistance Junction to Ambient Air	$R_{\theta JA}$	650 ⁽²⁾	°C/W
Junction Temperature	T_J	150	°C
Storage Temperature Range	T_S	-65 to + 150	°C

Notes:

- (1) Device on fiberglass substrate
- (2) Valid provided that electrodes are ambient temperature

ELECTRICAL CHARACTERISTICS

Rating at 25 °C ambient temperature unless otherwise specified

Type	Marking	Zener Voltage		Dynamic Resistance	Temp.Coefficient of Zener voltage at I_{ZT1}		Test Current	Dynamic Resistance at I_{ZT2}	Test Current	Reverse Leakage Current at	
		rang ⁽¹⁾ at I_{ZT1}			$\alpha_{VZ} (10^{-4}/K)$	$I_{ZT1} (mA)$				$r_{zj} (\Omega)$	$I_{ZT2} (mA)$
		min	max	$r_{zj} (\Omega)$			min	max			
BZX384C2V4	W1	2.20	2.60	70 (≤ 100)	-9.0	-4.0	5	275	1.0	50.0	1.0
BZX384C2V7	W2	2.50	2.90	75 (≤ 100)	-9.0	-4.0	5	300 (≤ 600)	1.0	20.0	1.0
BZX384C3V0	W3	2.80	3.20	80 (≤ 95)	-9.0	-3.0	5	325 (≤ 600)	1.0	10.0	1.0
BZX384C3V3	W4	3.10	3.50	85 (≤ 95)	-8.0	-3.0	5	350 (≤ 600)	1.0	5.00	1.0
BZX384C3V6	W5	3.40	3.80	85 (≤ 90)	-8.0	-3.0	5	375 (≤ 600)	1.0	5.00	1.0
BZX384C3V9	W6	3.70	4.10	85 (≤ 90)	-7.0	-3.0	5	400 (≤ 600)	1.0	3.00	1.0
BZX384C4V3	W7	4.00	4.60	80 (≤ 90)	-6.0	-1.0	5	410 (≤ 600)	1.0	3.00	1.0
BZX384C4V7	W8	4.40	5.00	50 (≤ 80)	-5.0	2.0	5	425 (≤ 500)	1.0	3.00	2.0
BZX384C5V1	W9	4.80	5.40	40 (≤ 60)	-3.0	4.0	5	400 (≤ 480)	1.0	2.00	2.0
BZX384C5V6	WA	5.20	6.00	15 (≤ 40)	-2.0	6.0	5	80 (≤ 400)	1.0	1.00	2.0
BZX384C6V2	WB	5.80	6.60	6.0 (≤ 10)	-1.0	7.0	5	40 (≤ 150)	1.0	3.00	4.0
BZX384C6V8	WC	6.40	7.20	6.0 (≤ 15)	2.0	7.0	5	30 (≤ 80)	1.0	2.00	4.0
BZX384C7V5	WD	7.00	7.90	6.0 (≤ 15)	3.0	7.0	5	30 (≤ 80)	1.0	1.00	5.0
BZX384C8V2	WE	7.70	8.70	6.0 (≤ 15)	4.0	7.0	5	40 (≤ 80)	1.0	0.70	5.0
BZX384C9V1	WF	8.50	9.60	6.0 (≤ 15)	5.0	8.0	5	40 (≤ 100)	1.0	0.50	6.0
BZX384C10	WG	9.40	10.6	8.0 (≤ 20)	5.0	8.0	5	50 (≤ 150)	1.0	0.20	7.0
BZX384C11	WH	10.4	11.6	10 (≤ 20)	5.0	9.0	5	50 (≤ 150)	1.0	0.10	8.0
BZX384C12	WI	11.4	12.7	10 (≤ 25)	6.0	9.0	5	50 (≤ 150)	1.0	0.10	8.0
BZX384C13	WK	12.4	14.1	10 (≤ 30)	7.0	9.0	5	50 (≤ 170)	1.0	0.10	8.0
BZX384C15	WL	13.8	15.6	10 (≤ 30)	7.0	9.0	5	50 (≤ 200)	1.0	0.05	0.7 Vznom.
BZX384C16	WM	15.3	17.1	10 (≤ 40)	8.0	9.5	5	50 (≤ 200)	1.0	0.05	0.7 Vznom.
BZX384C18	WN	16.8	19.1	10 (≤ 45)	8.0	9.5	5	50 (≤ 225)	1.0	0.05	0.7 Vznom.
BZX384C20	WO	18.8	21.2	15 (≤ 55)	8.0	10.0	5	60 (≤ 225)	1.0	0.05	0.7 Vznom.
BZX384C22	WP	20.8	23.3	20 (≤ 55)	8.0	10.0	5	60 (≤ 250)	1.0	0.05	0.7 Vznom.
BZX384C24	WR	22.8	25.6	25 (≤ 70)	8.0	10.0	5	60 (≤ 250)	1.0	0.05	0.7 Vznom.
BZX384C27	WS	25.1	28.9	25 (≤ 80)	8.0	10.0	2	65 (≤ 300)	0.5	0.05	0.7 Vznom.
BZX384C30	WT	28.0	32.0	30 (≤ 80)	8.0	10.0	2	70 (≤ 300)	0.5	0.05	0.7 Vznom.
BZX384C33	WU	31.0	35.0	35 (≤ 80)	8.0	10.0	2	75 (≤ 325)	0.5	0.05	0.7 Vznom.
BZX384C36	WW	34.0	38.0	35 (≤ 90)	8.0	10.0	2	80 (≤ 350)	0.5	0.05	0.7 Vznom.
BZX384C39	WX	37.0	41.0	40 (≤ 130)	10.0	12.0	2	80 (≤ 350)	0.5	0.05	0.7 Vznom.
BZX384C43	WY	40.0	46.0	45 (≤ 150)	10.0	12.0	2	85 (≤ 375)	0.5	0.05	0.7 Vznom.
BZX384C47	WZ	44.0	50.0	50 (≤ 170)	10.0	12.0	2	85 (≤ 375)	0.5	0.05	0.7 Vznom.
BZX384C51	X1	48.0	54.0	60 (≤ 180)	10.0	12.0	2	85 (≤ 400)	0.5	0.05	0.7 Vznom.
BZX384C56	X2	52.0	60.0	70 (≤ 200)	9.0	11.0	2	100 (≤ 425)	0.5	0.05	0.7 Vznom.
BZX384C62	X3	58.0	66.0	80 (≤ 215)	9.0	12.0	2	100 (≤ 450)	0.5	0.05	0.7 Vznom.
BZX384C68	X4	64.0	72.0	90 (≤ 240)	10.0	12.0	2	150 (≤ 475)	0.5	0.05	0.7 Vznom.
BZX384C75	X5	70.0	79.0	95 (≤ 255)	10.0	12.0	2	170 (≤ 500)	0.5	0.05	0.7 Vznom.

Notes :

 (1) Measured with pulses $p = 5$ ms