

D/A Converter Series for Electronic Adjustments

High-precision 10bit



4ch - 6ch Type D/A Converters

BU2508FV, BU2507FV

●Description

BU2508FV and BU2507FV ICs are high performance 10bit R-2R-type DACs with 4ch and 6ch outputs, respectively. Each channel incorporates a full swing output-type buffer amplifier with high speed output response characteristics, resulting in a greatly shortened wait time. The ICs also utilize the TTL level input method.

●Features

- 1) High performance, multi-channels R-2R-type 10bit D/A converter built-in (BU2508FV: 4 channels, BU2507FV: 6 channels)
- 2) Full swing output type buffer amplifier incorporated at each output channel
- 3) The RESET terminal can keep the voltage of all channels within the lower reference voltage range
- 4) Digital input compatible with TTL levels
- 5) 14bit 3-line serial data + RESET signal input (address 4bit + data 10bit)
- 6) Compact package: 14 pins, 0.65mm pitch (SSOP-B14)

●Applications

DVDs, CD-Rs, CD-RWs, digital cameras

●Lineup

Parameter	BU2507FV	BU2508FV
Power source voltage range	4.5 to 5.5 V	4.5 to 5.5 V
Number of channels	6ch	4ch
Differential non linearity error	±1.0LSB	±1.0LSB
Integral non linearity error	±3.5LSB	±3.5LSB
Data transfer frequency	10MHz	10MHz
Package	SSOP-B14	SSOP-B14

● Absolute Maximum Ratings (Ta=25°C)

Parameter	Symbol	Limits	Unit
Power source voltage	VCC	-0.3 to 6.0	V
D/A converter upper standard voltage	VDD	-0.3 to 6.0	V
Input voltage	VIN	-0.3 to 6.0	V
Output voltage	VOUT	-0.3 to 6.0	V
Storage temperature range	Tstg	-55 to 125	°C
Power dissipation	Pd	350 *	mW

*Derated at 3.5mW/°C at Ta>25°C, mounted on a 70x70x1.6mm FR4 glass epoxy board (copper foil area less than 3%)

Note: These products are not robust against radiation

● Recommended Operating Conditions (Ta=25°C)

Parameter	Symbol	Limits	Unit
Power supply voltage range	VCC	4.5 to 5.5	V
Operating temperature range	Topr	-30 to 85	°C

● Electrical Characteristics (Unless otherwise specified, VCC=5V, VrefH=5V, VrefL=0V, Ta=25°C)

Parameter	Symbol	Limits			Unit	Conditions	
		MIN.	TYP.	MAX.			
<Digital unit>							
Power source current	ICC	-	0.85	2.8	mA	At CLK = 10MHz, IAO = 0uA	
Input leak current	IILK	-5	-	5	µA	VIN=0 to VCC	
Input voltage L	VIL	-	-	0.8	V		
Input voltage H	VIH	2.0	-	-	V		
Output voltage L	VOL	0	-	0.4	V	IOL=2.5mA	
Output voltage H	VOH	4.6	-	5	V	IOH=-2.5mA	
<Analog unit>							
Consumption current	IrefH	-	4.5	7.5	mA	Data condition : at maximum current	
		-	2.0	3.4	mA ^(*)		
D/A converter upper standard voltage setting range	VrefH	3.0	-	5	V	Outputs does not necessarily take a value in standard voltage setting range. Value that output may take is in the buffer amplifier output voltage range (VO).	
D/A converter lower standard voltage setting range	VrefL	0	-	1.5	V		
Buffer amplifier output voltage range	VO	0.1	-	4.9	V	IO=±100µA IO=±1.0mA	
		0.2	-	4.75			
Buffer amplifier output drive range	IO	-2	-	2	mA	Upper saturation voltage =0.35V Lower saturation voltage =0.23V	
Precision	Differential non-linearity error	DNL	-1.0	-	1.0	LSB	VrefH =4.796V VrefL=0.7V VCC=5.5V (4mV/LSB) No load (IO = +0mA)
	Integral non-linearity error	INL	-3.5	-	3.5		
	Zero point error	SZERO	-25	-	25	mV	
	Full scale error	SFULL	-25	-	25		
Buffer amplifier output impedance	RO	-	5	15	Ω		
Pull-up I/O internal resistance value	Rup	12.5	25	37.5	kΩ	Input voltage 0V (Resistance value changes according to voltage to be impressed.)	

*1: Value in the case where CH1 ~ CH4 are set to maximum current

● Timing Characteristics (Unless otherwise specified, VCC=5V, VrefH=5V, VrefL=0V, Ta=25°C)

Parameter	Symbol	Limits			Unit	Conditions Judgment level is 80% / 20% of VCC.
		MIN.	TYP.	MAX.		
Reset L pulse width	tRTL	50	-	-	nS	
Clock L pulse width	tCKL	50	-	-		
Clock H pulse width	tCKH	50	-	-		
Clock rise time	tcr	-	-	50		
Clock fall time	tcf	-	-	50		
Data setup time	tDCH	20	-	-		
Data hold time	tCHD	40	-	-		
Load setup time	tCHL	50	-	-		
Load hold time	tLDC	50	-	-		
Load H pulse width	tLDH	50	-	-		
DA output settling time	tLDD	-	7	20	μS	CL ≤ 1000pF, VO: 0.5V ⇔ 4.5V . Until output becomes the final value 1/2LSB

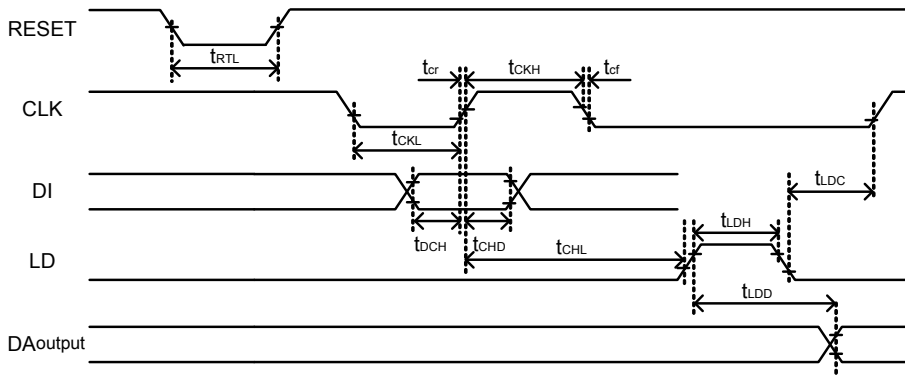

● DAC Variable Output Range Function

With the variable output range function, the upper / lower limits of the output voltage as well as the power supply voltage can be set.

The upper limit value setting terminal VrefH is used as the power supply terminal, while the lower limit value setting terminal VrefL is used as the GND terminal (1LSB ≅ 5mV). In the example below, VrefH = 3.5V / VrefL = 1.5V. Further adjustments can be made in order to achieve greater accuracy (1LSB ≅ 2mV).

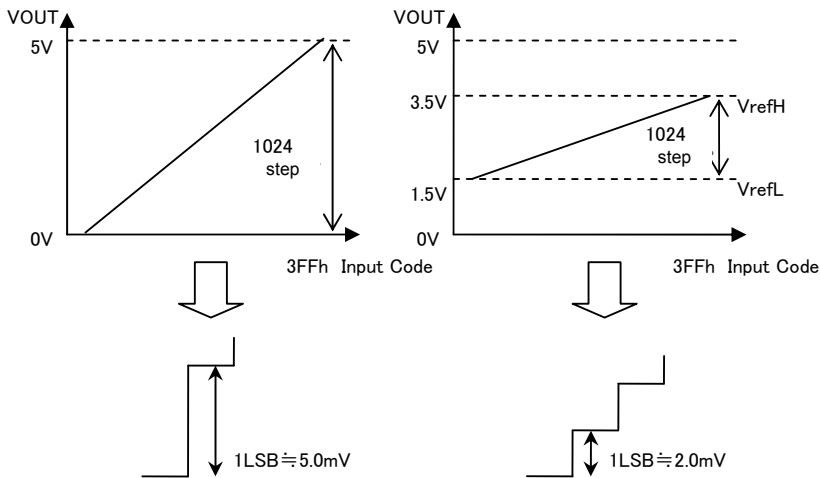

● Block Diagrams

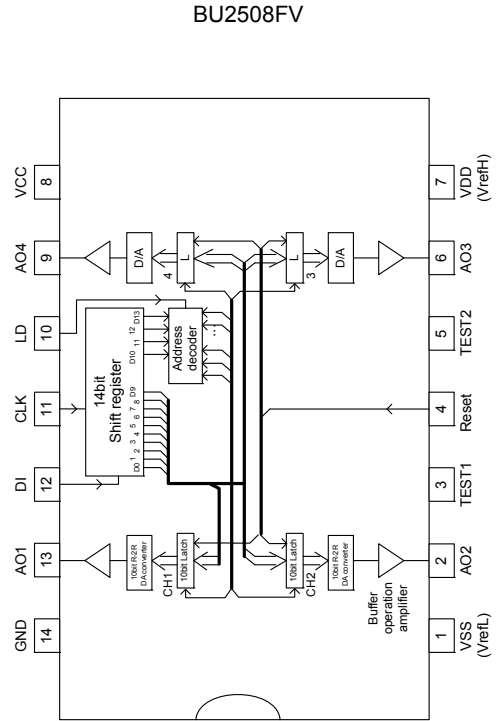
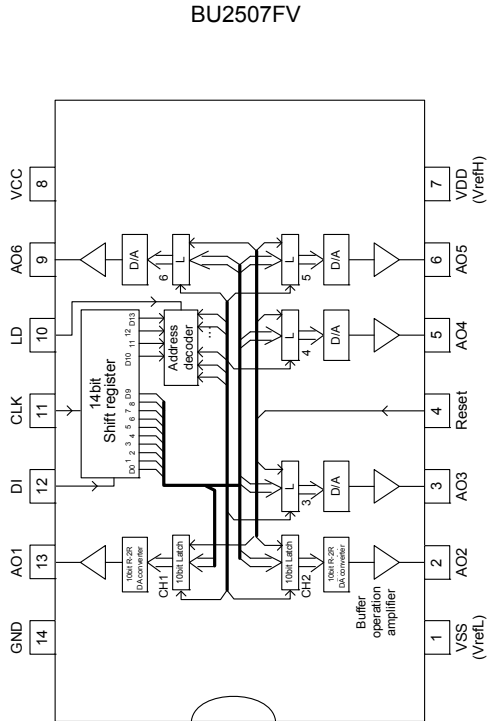

● Terminal Description

No	Terminal name	Analog / Digital	I/O	Description of terminal	Equivalent circuit
1	VSS	Analog	-	DA converter lower standard voltage (VrefL) input terminal	6
2	AO2	Analog	O	10bit D/A output (CH2)	4
3	AO3(TEST1)	Analog	O	10bit D/A output (CH3) (BU2508FV : test terminal)	4
4	Reset	Digital	I	All ch analog output L fixed	2
5	AO4(TEST2)	Digital	I	10bit D/A output (CH4) (BU2508FV : test terminal)	4
6	AO5 (AO3)	Analog	O	10bit D/A output (CH5) (BU2508FV : 10bit D/A output (CH3))	4
7	VDD	Analog	-	DA converter upper standard voltage (VrefH) input terminal	5
8	VCC	-	-	Power source terminal	-
9	AO6 (AO4)	Analog	O	10bit D/A output (CH6) (BU2508FV : 10bit D/A output (CH4))	4
10	LD	Digital	I	When High level is input to LD terminal, the value of 14bit shift register is loaded to decoder and D/A output register.	1
11	CLK	Digital	I	Shift clock input terminal. At rise of shift clock, the signal from DI terminal is input to 14bit shift register.	1
12	DI	Digital	I	Serial data input terminal. Serial data whose data length is 14bit (address 4bit + data 10bit) is input.	1
13	AO1	Analog	O	10bit D/A output (CH1)	4
14	GND	-	-	GND terminal	-

*In the case of BU2508FV, be sure to open TEST1 and TEST2 terminals.

● Command Sending

1) In the case of BU2507FV

(1) Data format [data : LSB first]

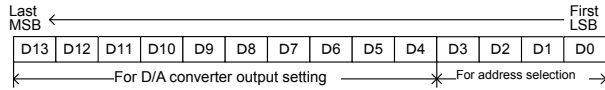

(2) Data timing diagram

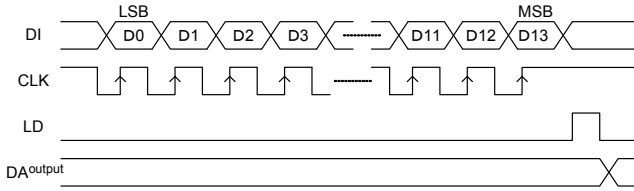

D3	D2	D1	D0	Address selection
0	0	0	0	Inconsequential
0	0	0	1	Inconsequential
0	0	1	0	AO1 selection
0	0	1	1	AO2 selection
0	1	0	0	Inconsequential
0	1	0	1	AO3 selection
0	1	1	0	AO4 selection
0	1	1	1	Inconsequential
1	0	0	0	AO5 selection
1	0	0	1	AO6 selection
1	0	1	0	Inconsequential
1	0	1	1	Inconsequential
1	1	0	0	Inconsequential
1	1	0	1	Inconsequential
1	1	1	0	Inconsequential
1	1	1	1	Inconsequential

D13	D12	D11	D10	D9	D8	D7	D6	D5	D4	D/A output (VrefH=VDD, VrefL=VSS)
0	0	0	0	0	0	0	0	0	0	VrefL
0	0	0	0	0	0	0	0	0	1	$(VrefH-VrefL)/1024 \times 1 + VrefL$
0	0	0	0	0	0	0	0	1	0	$(VrefH-VrefL)/1024 \times 2 + VrefL$
0	0	0	0	0	0	0	0	1	1	$(VrefH-VrefL)/1024 \times 3 + VrefL$
:	:	:	:	:	:	:	:	:	:	:
1	1	1	1	1	1	1	1	1	0	$(VrefH-VrefL)/1024 \times 1022 + VrefL$
1	1	1	1	1	1	1	1	1	1	$(VrefH-VrefL)/1024 \times 1023 + VrefL$

2) In the case of BU2508FV

(1) Data format [Data: LSB first]

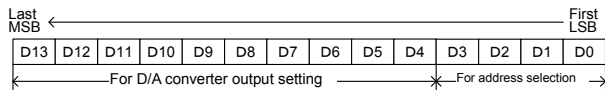

(2) Data timing diagram

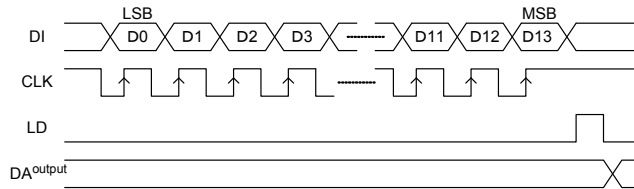

D3	D2	D1	D0	Address selection
0	0	0	0	Don't Care
0	0	0	1	Don't Care
0	0	1	0	AO1 selection
0	0	1	1	AO2 selection
0	1	0	0	Don't Care
0	1	0	1	Don't Care
0	1	1	0	Don't Care
0	1	1	1	Don't Care
1	0	0	0	AO3 selection
1	0	0	1	AO4 selection
1	0	1	0	Don't Care
1	0	1	1	Don't Care
1	1	0	0	Don't Care
1	1	0	1	Don't Care
1	1	1	0	Don't Care
1	1	1	1	Don't Care

D13	D12	D11	D10	D9	D8	D7	D6	D5	D4	D/A output (VrefH=VDD, VrefL=VSS)
0	0	0	0	0	0	0	0	0	0	VrefL
1	0	0	0	0	0	0	0	0	0	$(VrefH-VrefL)/1024 \times 1 + VrefL$
0	1	0	0	0	0	0	0	0	0	$(VrefH-VrefL)/1024 \times 2 + VrefL$
1	1	0	0	0	0	0	0	0	0	$(VrefH-VrefL)/1024 \times 3 + VrefL$
:	:	:	:	:	:	:	:	:	:	:
0	1	1	1	1	1	1	1	1	1	$(VrefH-VrefL)/1024 \times 1022 + VrefL$
1	1	1	1	1	1	1	1	1	1	$(VrefH-VrefL)/1024 \times 1023 + VrefL$

● Electrical Characteristics Curves

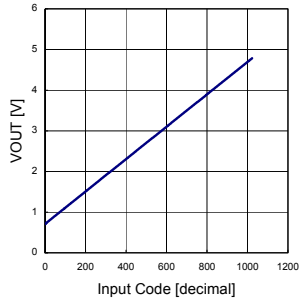

Fig. 1 Output voltage linearity (-30°C)

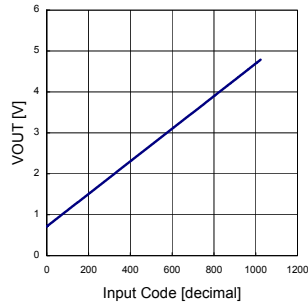

Fig. 2 Output voltage linearity (25°C)

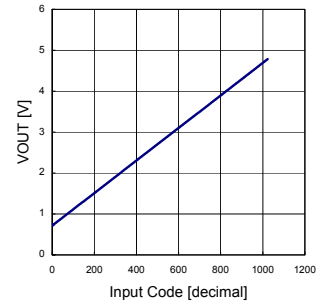

Fig. 3 Output voltage linearity (85°C)

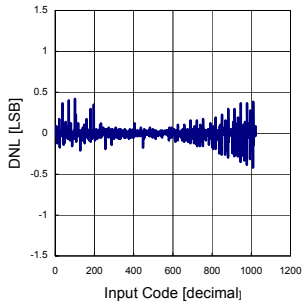

Fig. 4 Differential linearity error (-30°C)

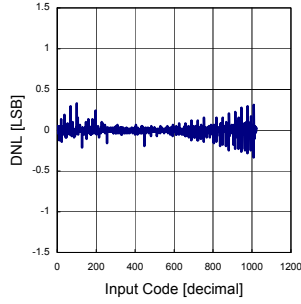

Fig. 5 Differential linearity error (25°C)

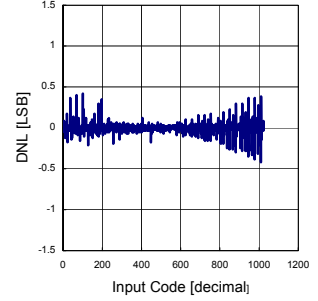

Fig. 6 Differential linearity error (85°C)

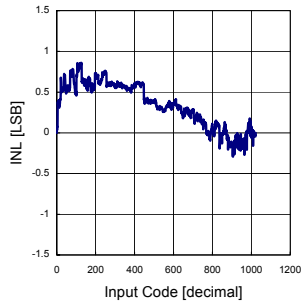

Fig. 7 Integral linearity error (-30°C)

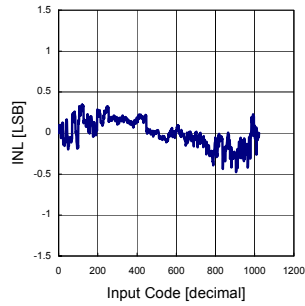

Fig. 8 Integral linearity error (25°C)

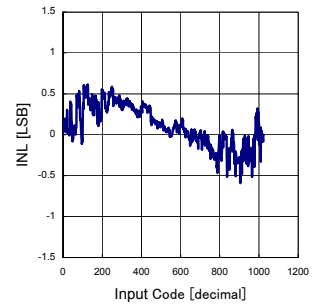

Fig. 9 Integral linearity error (85°C)

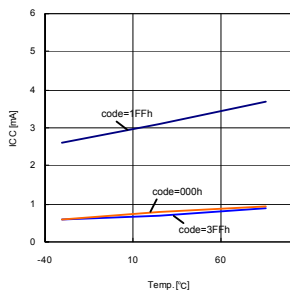

Fig. 10 Circuit current temperature characteristic

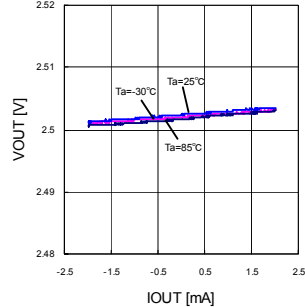

Fig. 11 Output load fluctuation characteristic (input code : 1FFh)

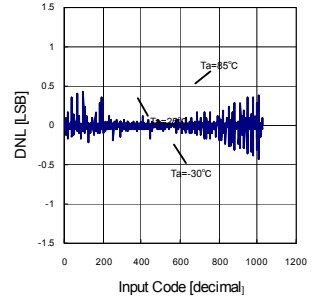
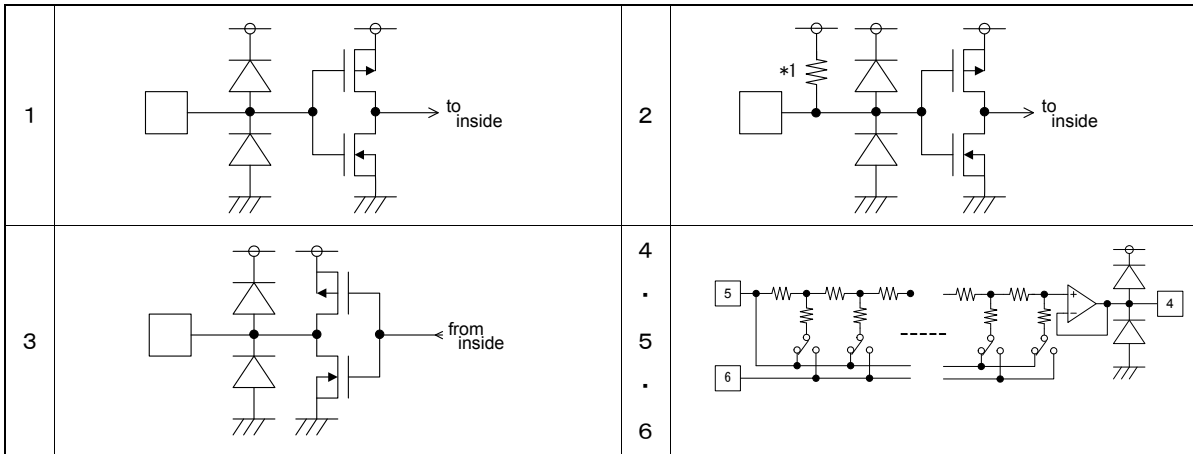

Fig. 12 Pull-up built in resistance characteristic

● Equivalent Circuits



*1: 25kΩ at Vcc = 5.0V (changes according to voltage supplied)

● Standard Example Application Circuit

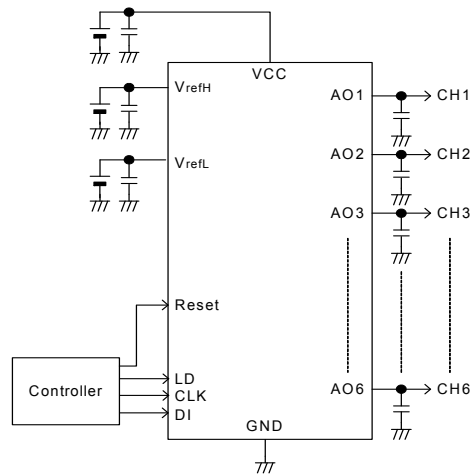

● Operation Notes

Ensure that a constant voltage is supplied to each of the 1 ground and 3 power supply terminals.

Insert a bypass capacitor between each power supply terminal and ground in order to prevent deterioration of the D/A conversion accuracy due to ripple and noise signals.

A capacitor should be inserted between the output and ground in order to eliminate jitter and noise. A capacitance up to 100pF is recommended (including the capacitance of the wire).

Inserting a capacitor between the RESET terminal and GND and utilizing a time constant enables power ON reset functionality.

Furthermore, when inputting the reset signal from the controller, it is possible to fix the output of all channels to Low at the low area of pulse.

●Part Number Explanation

B	U	2	5	0	7	F	V	-	E	2
ROHM Product Name		Part No.				Package type		Taping name Reel embossed carrier tape		

B	U	2	5	0	8	F	V	-	E	2
ROHM Product Name		Part No.				Package type		Taping name Reel embossed carrier tape		

SSOP-B14

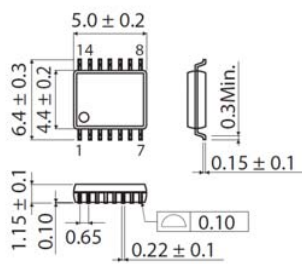
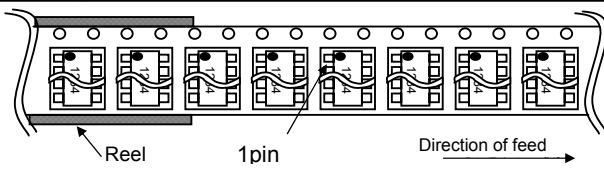
<p>Dimensions</p>  <p style="text-align: right;">(Unit:mm)</p>	<p>Tape and Reel Information</p> <table border="1" style="width: 100%; border-collapse: collapse;"> <tr> <td style="width: 20%;">Tape</td> <td>Embossed carrier tape</td> </tr> <tr> <td>Quantity</td> <td>2,500pcs</td> </tr> <tr> <td>Direction of taping</td> <td>E2 (Pin 1 is at the upper left when holding the reel with the left hand and pulling the tape out towards the right)</td> </tr> </table>  <p style="text-align: center;">*Please order in multiples of the minimum package size</p>	Tape	Embossed carrier tape	Quantity	2,500pcs	Direction of taping	E2 (Pin 1 is at the upper left when holding the reel with the left hand and pulling the tape out towards the right)
Tape	Embossed carrier tape						
Quantity	2,500pcs						
Direction of taping	E2 (Pin 1 is at the upper left when holding the reel with the left hand and pulling the tape out towards the right)						

Notes

- No technical content pages of this document may be reproduced in any form or transmitted by any means without prior permission of ROHM CO.,LTD.
- The contents described herein are subject to change without notice. The specifications for the product described in this document are for reference only. Upon actual use, therefore, please request that specifications to be separately delivered.
- Application circuit diagrams and circuit constants contained herein are shown as examples of standard use and operation. Please pay careful attention to the peripheral conditions when designing circuits and deciding upon circuit constants in the set.
- Any data, including, but not limited to application circuit diagrams information, described herein are intended only as illustrations of such devices and not as the specifications for such devices. ROHM CO.,LTD. disclaims any warranty that any use of such devices shall be free from infringement of any third party's intellectual property rights or other proprietary rights, and further, assumes no liability of whatsoever nature in the event of any such infringement, or arising from or connected with or related to the use of such devices.
- Upon the sale of any such devices, other than for buyer's right to use such devices itself, resell or otherwise dispose of the same, no express or implied right or license to practice or commercially exploit any intellectual property rights or other proprietary rights owned or controlled by
- ROHM CO., LTD. is granted to any such buyer.
- Products listed in this document are no antiradiation design.

The products listed in this document are designed to be used with ordinary electronic equipment or devices (such as audio visual equipment, office-automation equipment, communications devices, electrical appliances and electronic toys).

Should you intend to use these products with equipment or devices which require an extremely high level of reliability and the malfunction of which would directly endanger human life (such as medical instruments, transportation equipment, aerospace machinery, nuclear-reactor controllers, fuel controllers and other safety devices), please be sure to consult with our sales representative in advance.

It is our top priority to supply products with the utmost quality and reliability. However, there is always a chance of failure due to unexpected factors. Therefore, please take into account the derating characteristics and allow for sufficient safety features, such as extra margin, anti-flammability, and fail-safe measures when designing in order to prevent possible accidents that may result in bodily harm or fire caused by component failure. ROHM cannot be held responsible for any damages arising from the use of the products under conditions out of the range of the specifications or due to non-compliance with the NOTES specified in this catalog.

Thank you for your accessing to ROHM product informations.

More detail product informations and catalogs are available, please contact your nearest sales office.

ROHM Customer Support System

THE AMERICAS / EUROPE / ASIA / JAPAN

www.rohm.com

Contact us : webmaster@rohm.co.jp