

1MBI150NH-060

IGBT Module

600V / 150A Chopper Module

■ Features

- High speed switching
- Low inductance module structure
- Suitable for Chopper and Dynamic brake circuit

■ Applications

- Uninterruptible power supply
- Inverter for Motor drive



■ Maximum ratings and characteristics

● Absolute maximum ratings (at Tc=25°C unless otherwise specified)

Item	Symbol	Rating	Unit	
IGBT	Collector-Emitter voltage	V _{CES}	600 V	
	Gate-Emitter voltage	V _{GES}	±20 V	
	Collector current	Continuous	I _C	150 A
		1ms	I _{C pulse}	300 A
Max. power dissipation	P _C	600 W		
FWD	Repetitive peak dissipation	V _{RRM}	600 V	
	Forward current	I _F	150 A	
		1ms	I _{F pulse}	300 A
Operating temperature	T _J	+150 °C		
Storage temperature	T _{stg}	-40 to +125 °C		
Isolation voltage	V _{is}	AC 2500 (1min.) V		
Screw torque	Mounting *1	3.5 N·m		
	Terminals *1	3.5 N·m		

*1 : Recommendable value : 2.5 to 3.5 N·m (M5)

■ Equivalent Circuit Schematic

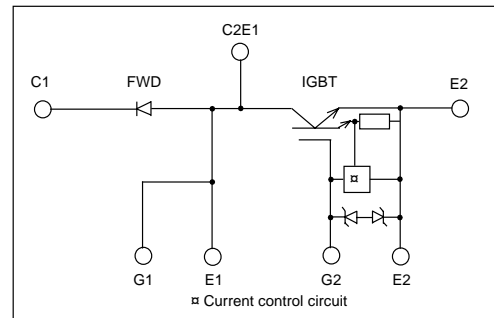

● Electrical characteristics (at Tj=25°C unless otherwise specified)

Item	Symbol	Characteristics			Conditions	Unit	
		Min.	Typ.	Max.			
IGBT	Zero gate voltage collector current	I _{CEs}	-	-	1.0	V _{GE} =0V, V _{CES} =600V	mA
	Gate-Emitter leakage current	I _{GES}	-	-	15	V _{CES} =0V, V _{GE} =±20V	μA
	Gate-Emitter threshold voltage	V _{GE(th)}	4.5	-	7.5	V _{CES} =20V, I _C =150mA	V
	Collector-Emitter saturation voltage	V _{CE(sat)}	-	-	2.8	V _{GE} =15V, I _C =150A	V
	Input capacitance	C _{ies}	-	9900	-	V _{GE} =0V	pF
	Output capacitance	C _{oes}	-	2200	-	V _{CES} =10V	
	Reverse transfer capacitance	C _{res}	-	1000	-	f=1MHz	
	Turn-on time	t _{on}	-	0.6	1.2	V _{CC} =300V	μs
			-	0.2	0.6	I _C =150A	
		Turn-off time	t _{off}	-	0.6	1.0	
t _f			-	0.2	0.35	R _G =16ohm	
FWD	Diode forward on voltage	V _F	-	-	3.0	I _F =150A, V _{GE} =0V	V
	Reverse recovery time	t _{rr}	-	-	0.3	I _F =150A	μs
	Reverse current	I _{RRM}	-	-	1.0	V _R =600V	mA

● Thermal resistance characteristics

Item	Symbol	Characteristics			Conditions	Unit
		Min.	Typ.	Max.		
Thermal resistance	R _{th(j-c)}	-	-	0.21	IGBT	°C/W
	R _{th(j-c)}	-	-	0.47	FWD	°C/W
	R _{th(c-f)*2}	-	0.05	-	the base to cooling fin	°C/W

*2 : This is the value which is defined mounting on the additional cooling fin with thermal compound

■ Characteristics (Representative)

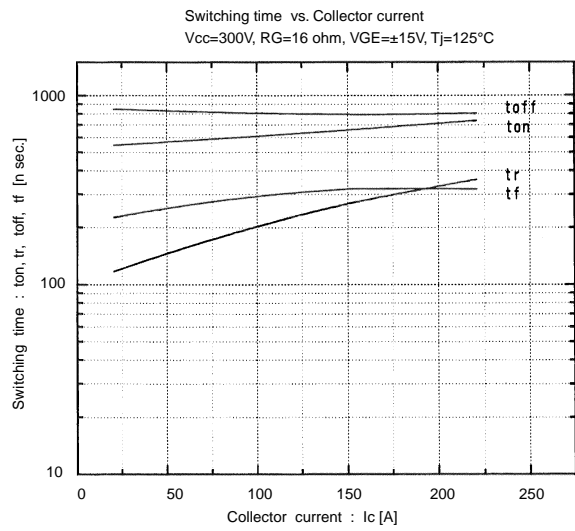
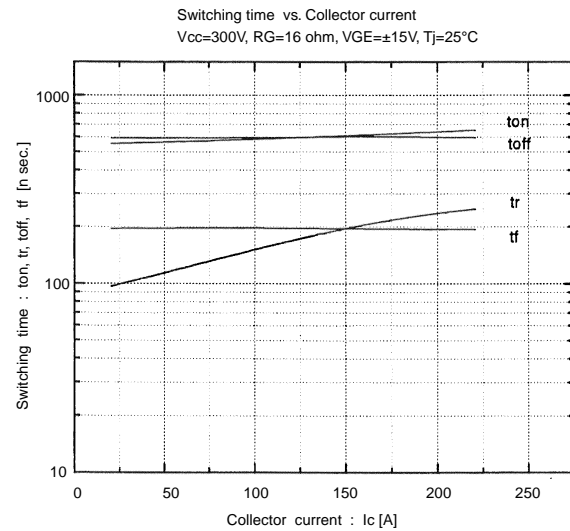
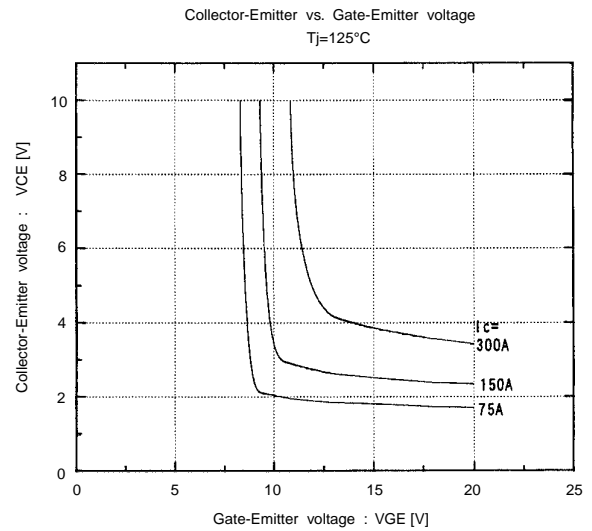
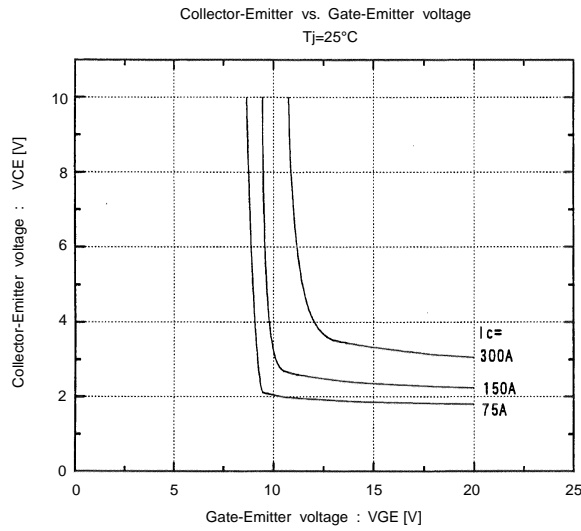
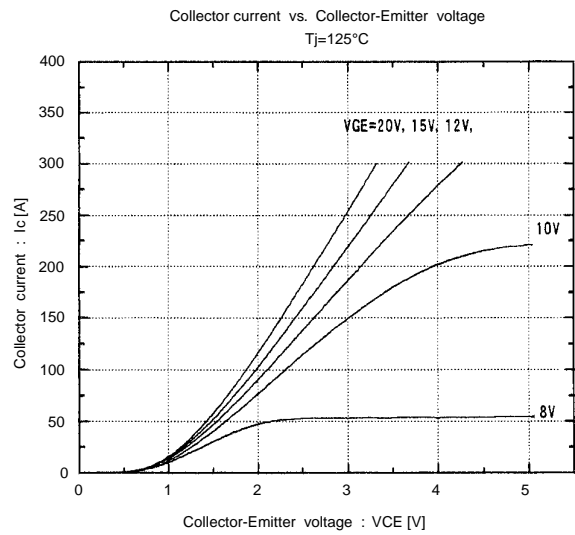
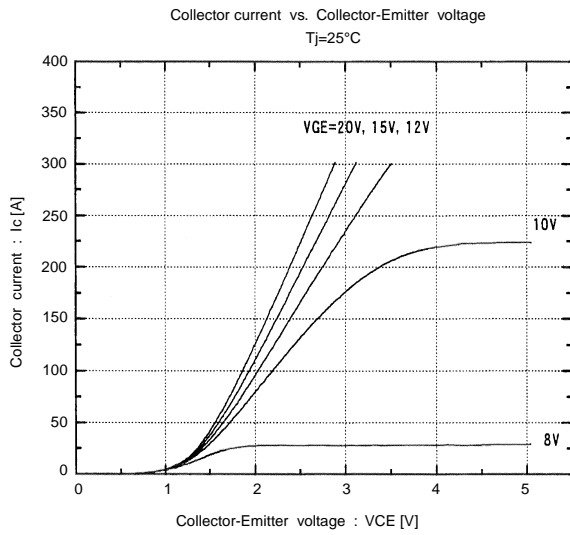

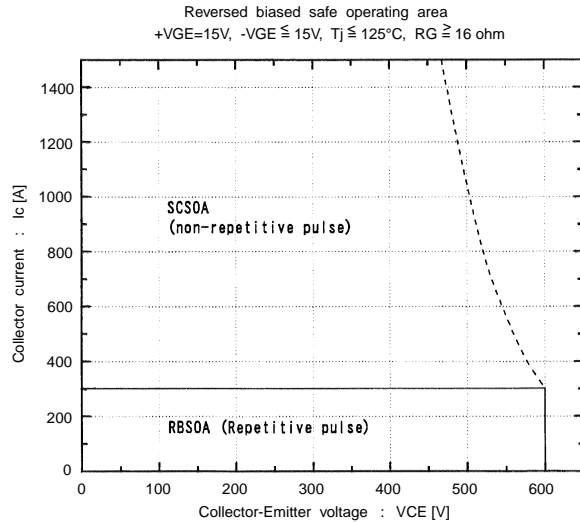
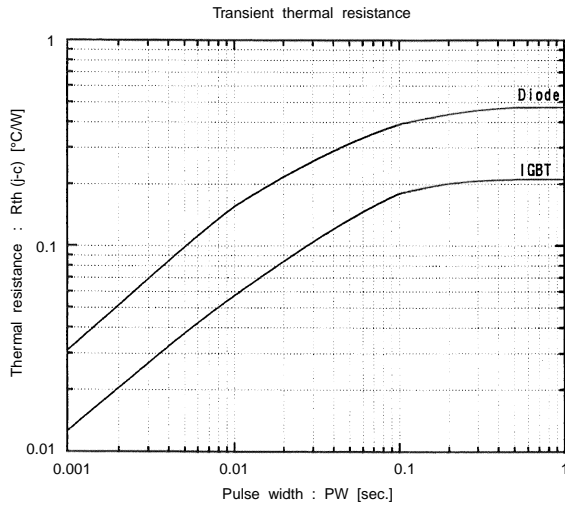
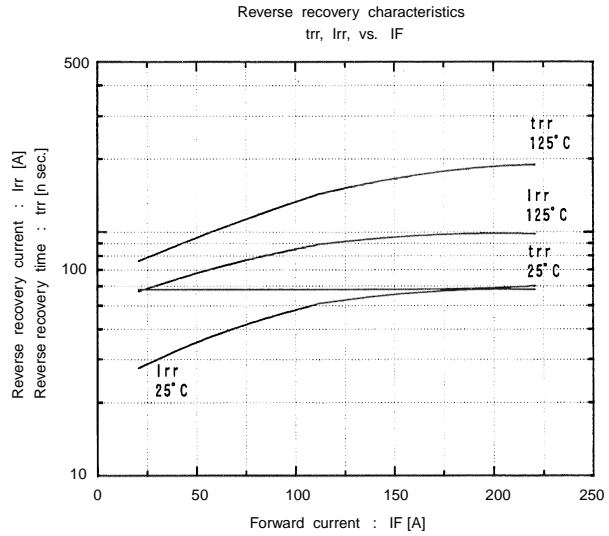
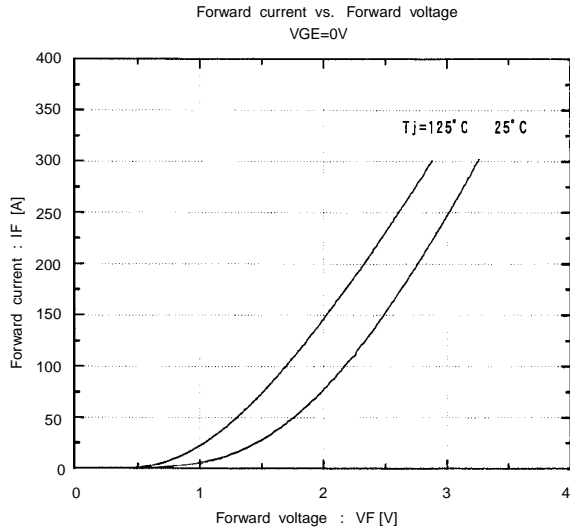
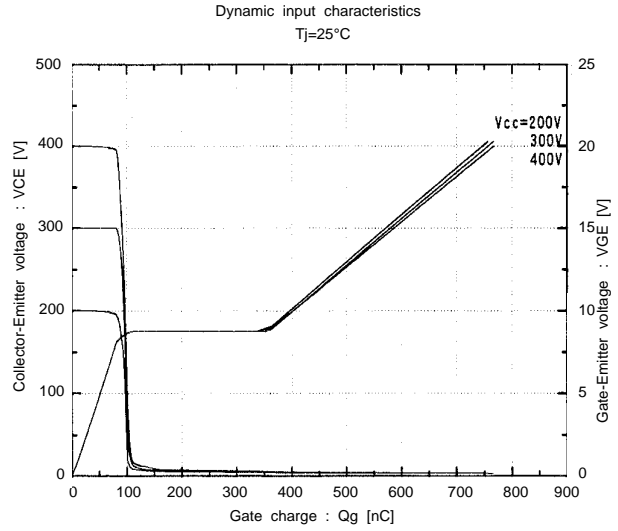
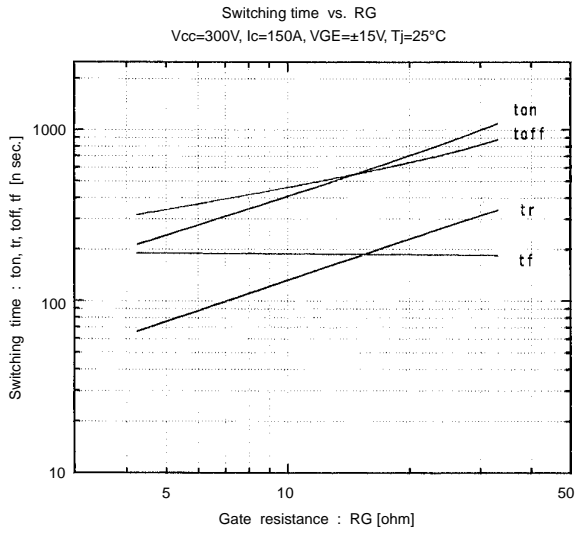

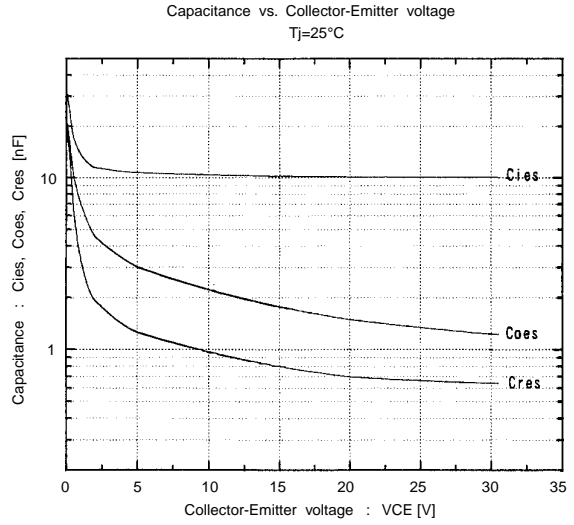
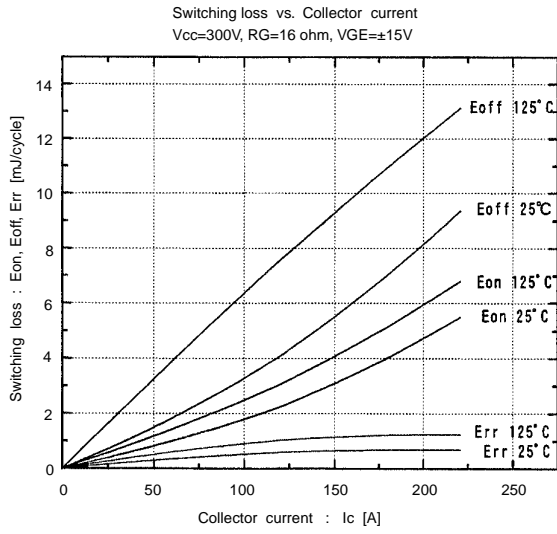

■ Outline Drawings, mm

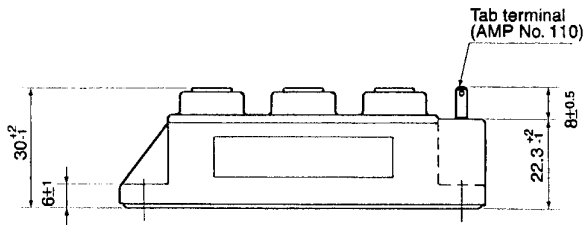
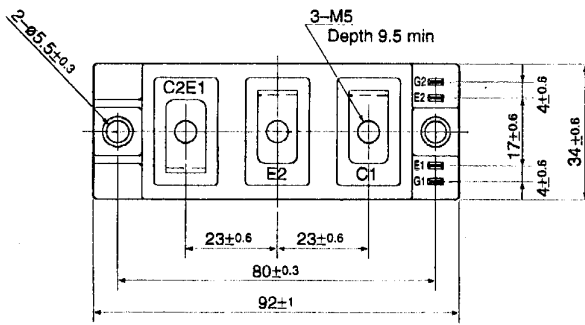

Mass : 180g