

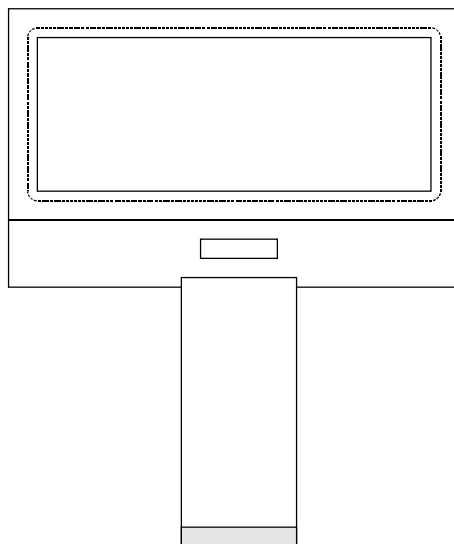

PRODUCT SPECIFICATION

HDG12864F-1

128x64 GRAPHICS
Chip-On-Glass
LCD DISPLAY MODULE



HANTRONIX, INC. 10080 BUBB RD. CUPERTINO, CA 95014	Q.A.: JK	REV.: 1.2	HDG12864F-1	SHEET 1 OF 21
				DATE: 7/22/03

1. MECHANICAL DATA

(1) Product No. HDG12864F-1
(2) Module Size 77.5 (W)mm x 51.3 (H)mm x MAX2.8 (D)mm
(W/O B.L.)
(3) Dot Size 0.48 (W)mm x 0.48 (H)mm
(4) Dot Pitch 0.52 (W)mm x 0.52 (H)mm
(5) Number of Characters 128 (W) x 64 (H)
(6) Duty 1/64
(9) LCD Display Mode STN: Gray Mode Yellow Mode Blue Mode
FSTN: Black and White(Normal White/Positive Image)
 Black and White(Normal Black/Negative Image)
Rear Polarizer: Reflective
(10) Viewing Direction 6 O'clock 12 O'clock ___O'clock
(11) Backlight W/O
(12) Weight 23.0 g (approx)
(13) Controller (COG) SED1565

HANTRONIX, INC. 10080 BUBB RD. CUPERTINO, CA 95014	Q.A.:	REV.:	HDG12864F-1	SHEET 2 OF 21
	JK	1.2		DATE: 7/22/03

2. ABSOLUTE MAXIMUM RATINGS

(1) ELECTRICAL ABSOLUTE RATINGS

VSS=0V

	SYMBOL	MIN	MAX	UNIT	COMMENT
Power Supply for Logic	VDD-VSS	-0.3	5.5	V	
Input Voltage	VI	-0.3	VDD	V	
Static Electricity	-	-	-	-	Note 1

Note 1 LCM should be grounded during handling LCM.

(2) ENVIRONMENTAL ABSOLUTE MAXIMUM RATINGS

ITEM	NORMAL TEMP.				WIDE TEMP.			
	OPERATING		STORAGE		OPERATING		STORAGE	
	MIN.	MAX.	MIN.	MAX.	MIN.	MAX.	MIN.	MAX.
Ambient Temperature	0	50	-20	70	-20	70	-30	80
Humidity (Without Condensation)	Note 2,4		Note 3,4		Note 4,5		Note 4,6	

Note 2 To $\leq 50^{\circ}\text{C}$: 85%RH max

To $> 50^{\circ}\text{C}$: Absolute humidity must be lower
than the humidity of 85%RH at 50°C

Note 3 To at -20°C will be $< 48\text{hrs}$, at 70°C will be $< 120\text{hrs}$

Note 4 Background color will change slightly depending on ambient temperature.
at phenomenon is reversible.

Note 5 To $\leq 70^{\circ}\text{C}$: 75%RH max



To $> 70^{\circ}\text{C}$: Absolute humidity must be lower
than the humidity of 75%RH at 70°C

Note 6 To at -30°C will be $< 48\text{hrs}$, at 80°C will be $< 120\text{hrs}$

HANTRONIX, INC. 10080 BUBB RD. CUPERTINO, CA 95014	Q.A.:	REV.:	HDG12864F-1	SHEET 3 OF 21
	JK	1.2		DATE:

3. ELECTRICAL CHARACTERISTICS

(VDD= 5V ± 10%)

ITEM	SYMBOL	CONDITION	MIN.	TYP.	MAX.	UNIT	
Input Voltage	VIH	H level	0.8VDD	-	VDD	V	
	VIL	L level	0	-	0.2VDD		
Recommended LCD Driving Voltage (WIDE TEMP. LCM)	VDD-V5 (VLCD)	DUTY= 1/64 Bios= 1/9	-20°C	10.6	11.0	11.4	V
			0°C	9.1	9.5	9.9	
			25°C	8.8	9.2	9.6	
			50°C	8.5	8.9	9.3	
			70°C	8.6	9.0	9.4	
Power Supply Current (VDD = 5V)	IDD	FLM = 70Hz VDD = 5.0V VDD-V5 = 9.2V 	-	0.7	1.1	mA	
Power Supply Current (VDD = 3V)	IDD	FLM = 70Hz VDD = 3.0V VDD-V5 = 9.2V 	-	1.6	2.4	mA	

HANTRONIX, INC. 10080 BUBB RD. CUPERTINO, CA 95014	Q.A.:	REV.:	HDG12864F-1	SHEET 4 OF 21
	JK	1.2		DATE:

4-1.OPTICAL CHARACTERISTICS

(FOR NORMAL TEMPERATURE MODE LCM)

AT V_{op}

MODE	ITEM	Cr(Contrast Ratio)		θ (Viewing Angle)		ϕ (Viewing Angle)	
		25 τ		25 τ		25 τ	
		MIN.	TYP.	MIN.	TYP.	MIN.	TYP.
R	A	-	3.5	-	43	-	49
	C	-	6.0	-	67	-	66
	J	-	5.5	-	70	-	65
S	A	-	-	-	-	-	-
	C	-	-	-	-	-	-
	J	-	6.0	-	63	-	69
NOTE		NOTE 6		NOTE 5			

NOTE :

R: REFLECTIVE
 S: TRANSFLECTIVE
 T: TRANSMISSIVE
 A/B: GRAY

C/D: YELLOW
 E/F: BLUE
 G/H: NORMALLY BLACK
 J/K: NORMALLY WHITE

AT $\theta=0^\circ$ $\theta=0^\circ$

ITEM	SYMBOL	CONDITION	MIN.	TYP.	MAX.	UNIT	NOTE
Response Time (rise)	Tr	0 τ	-	1400	2100	ms	NOTE 2
		25 τ	-	350	550		
		50 τ	-	160	240		
Response Time (fall)	Tf	0 τ	-	700	1100	ms	NOTE 2
		25 τ	-	180	270		
		50 τ	-	80	120		

HANTRONIX, INC. 10080 BUBB RD. CUPERTINO, CA 95014	Q.A.:	REV.:	HDG12864F-1	SHEET 5 OF 21
	JK	1.2		DATE:

4-2. OPTICAL CHARACTERISTICS

(FOR WIDE TEMPERATURE MODE LCM)

AT Vop

ITEM	MODE	Cr(Contrast Ratio)										θ (Viewing Angle)		ϕ (Viewing Angle)	
		-20℃		0℃		25℃		50℃		70℃		25℃		25℃	
		MIN.	TYP.	MIN.	TYP.	MIN.	TYP.	MIN.	TYP.	MIN.	TYP.	MIN.	TYP.	MIN.	TYP.
R	A	-	-	-	-	-	-	-	-	-	-	-	-	-	-
	C	-	-	-	-	-	-	-	-	-	-	-	-	-	-
	J	-	3.7	-	4.0	-	5.7	-	5.8	-	4.7	-	70	-	65
S	A	-	-	-	-	-	-	-	-	-	-	-	-	-	-
	C	-	-	-	-	-	-	-	-	-	-	-	-	-	-
	J	-	3.6	-	5.2	-	6.1	-	4.9	-	3.7	-	63	-	69
T	E	-	-	-	-	-	-	-	-	-	-	-	-	-	-
	G	-	-	-	-	-	-	-	-	-	-	-	-	-	-
NOTE	NOTE 6										NOTE 5				

NOTE :

R: REFLECTIVE
 S: TRANSFLECTIVE
 T: TRANSMISSIVE
 A/B: GRAY

C/D: YELLOW
 E/F: BLUE
 G/H: NORMALLY BLACK
 J/K: NORMALLY WHITE

AT $\phi=0^\circ$ $\theta=0^\circ$

ITEM	SYMBOL	CONDITION	MIN.	TYP.	MAX.	UNIT	NOTE
Response Time (rise)	Tr	-20℃	-	11240	-	ms	NOTE 2
		0℃	-	1450	-		
		25℃	-	350	-		
		50℃	-	145	-		
		70℃	-	75	-		
Response Time (fall)	Tf	-20℃	-	6200	-	ms	NOTE 2
		0℃	-	700	-		
		25℃	-	160	-		
		50℃	-	70	-		
		70℃	-	70	-		

HANTRONIX, INC. 10080 BUBB RD. CUPERTINO, CA 95014	Q.A.:	REV.:	HDG12864F-1	SHEET 6 OF 21
	JK	1.2		DATE:

(NOTE 1)

Definition of Operation Voltage(Vop)

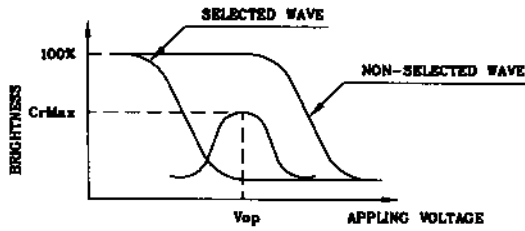

(positive type)

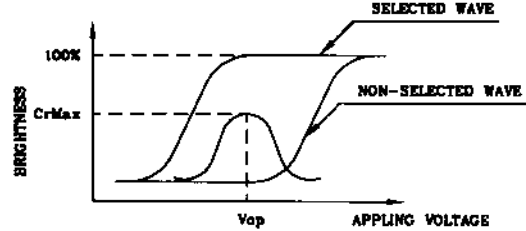

(negative type)

*Conditions

- Viewing Angle : 0
- Frame Frequency : 70Hz
- Applying Waveform : 1/N duty 1/a bias

(NOTE 2)

Definition of Response Time(Tr,Tf)

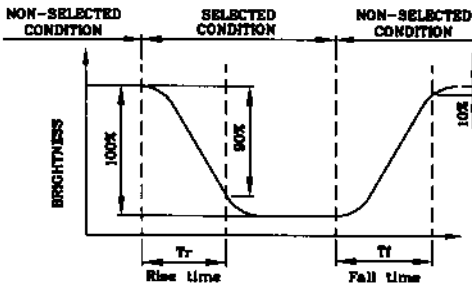

(positive type)

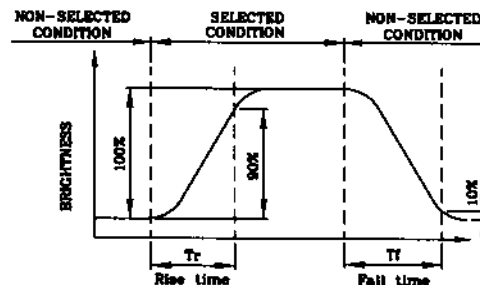

(negative type)

*Conditions

- Operating Voltage : Vop
- Viewing Angle (φ,s) : (0,0)
- Frame Frequency : 70Hz
- Applying Waveform : 1/N duty 1/a bias

(NOTE 3)

Description of Measuring Equipment and Driving Waveforms

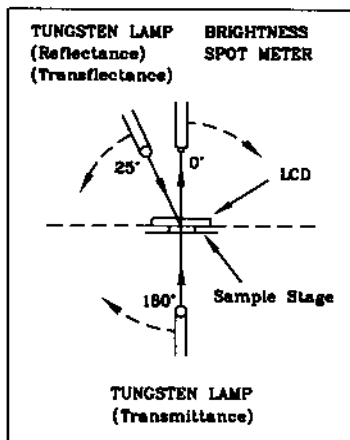

CONST.
TEMP.
CHAMBER

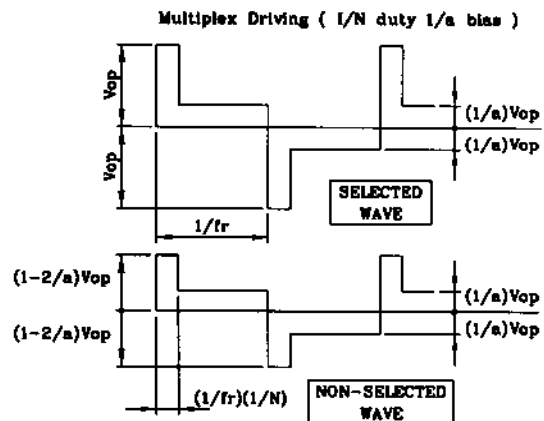

HANTRONIX, INC.
10080 BUBB RD.
CUPERTINO, CA 95014

Q.A.:
JK

REV.:
1.2

HDG12864F-1

SHEET 7 OF 21

DATE:
7/22/03

(NOTE 4)

Definition of Viewing Direction

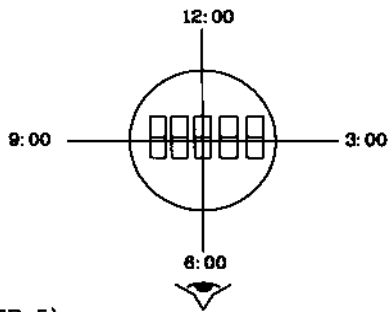

(NOTE 5)

Definition of Viewing Angle

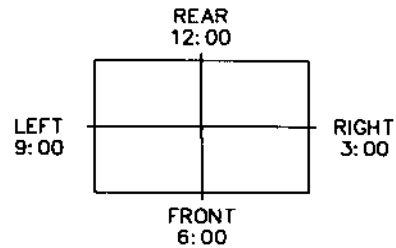
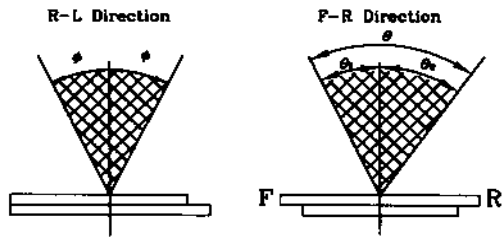

*For This Product
The Viewing Direction is 6 O'clock
So $\theta_1 > \theta_2$

$$\theta = \theta_1 + \theta_2$$

*Conditions

- Operating Voltage : V_{op}
- Frame Frequency : 70Hz
- Applying Waveform : 1/N duty 1/a bias
- Contrast Ratio : larger than 2

(NOTE 6)

Definition of Contrast Ratio (Cr)

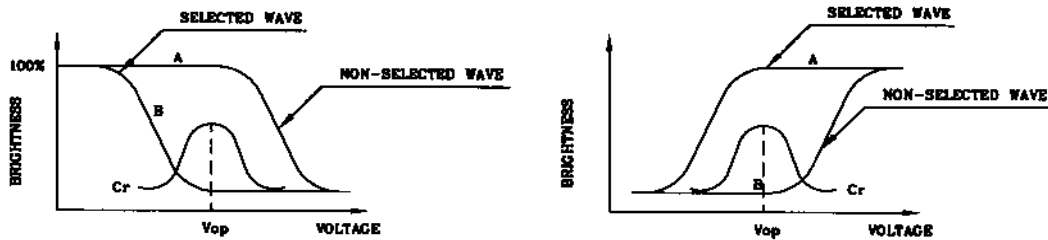

(positive type)

(negative type)

$$\text{Contrast Ratio : } Cr = A/B$$

*Conditions

- Viewing Angle : 0
- Frame Frequency : 70Hz
- Applying Waveform : 1/N duty 1/a bias

HANTRONIX, INC.
10080 BUBB RD.
CUPERTINO, CA 95014

Q.A.:
JK

REV.:
1.2

HDG12864F-1

SHEET 8 OF 21

DATE:
7/22/03

5. MPU INTERFACE/BLOCK DIAGRAM

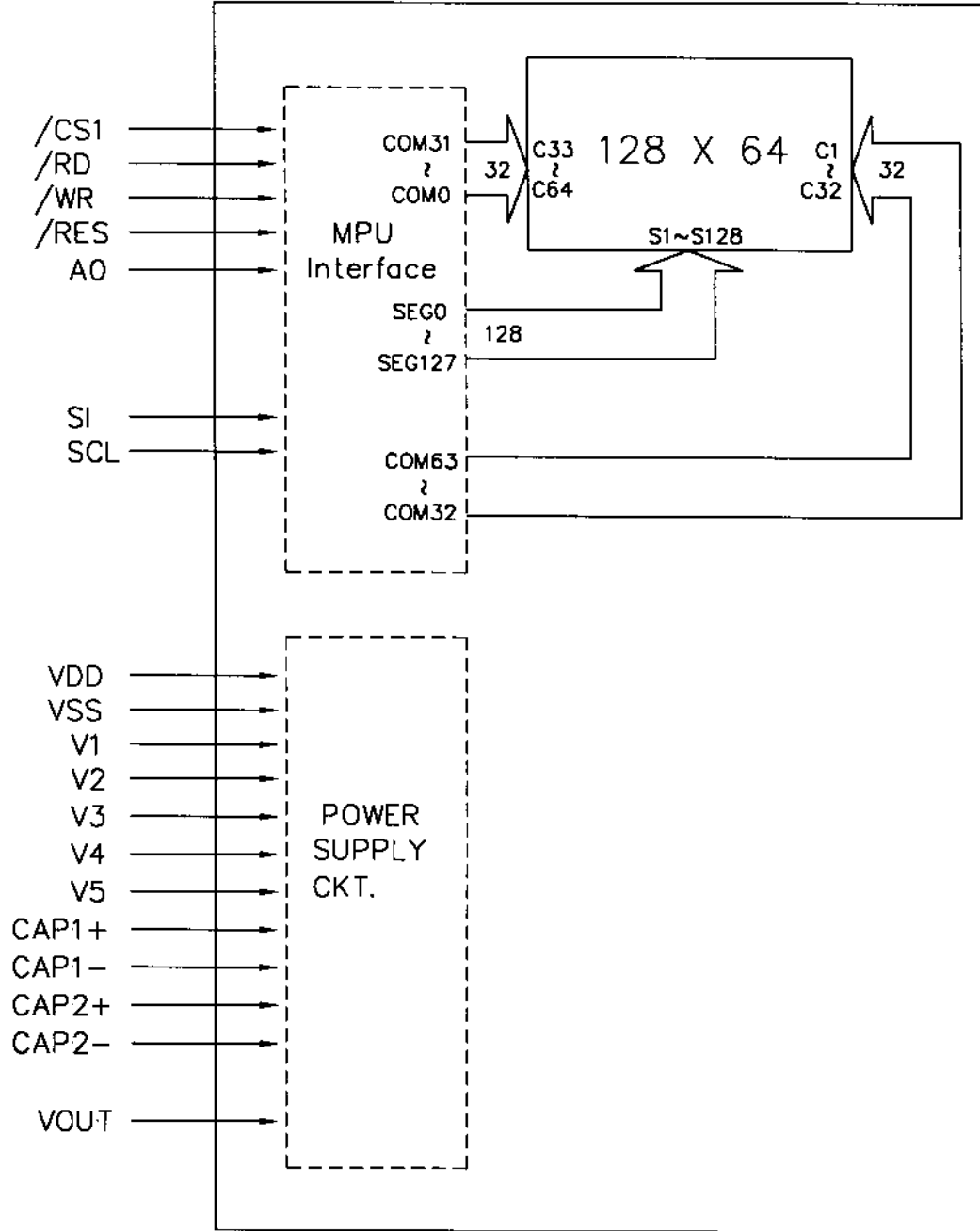

HANTRONIX, INC. 10080 BUBB RD. CUPERTINO, CA 95014	Q.A.:	REV.:	HDG12864F-1	SHEET 9 OF 21
	JK	1.2		DATE:

6. INTERNAL PIN CONNECTION

Pin No.	Symbol	Function
1	V5	This is a multi-level power supply for the liquid crystal drive. $VDD(=V0) \geq V1 \geq V2 \geq V3 \geq V4 \geq V5$
2	V4	
3	V3	
4	V2	
5	V1	
6	N.C	N.C
7	CAP2+	Connect a capacitor between this terminal and the CAP2- terminal.
8	CAP2-	Connect a capacitor between this terminal and the CAP2+ terminal.
9	CAP1-	Connect a capacitor between this terminal and the CAP1+ terminal.
10	CAP1+	Connect a capacitor between this terminal and the CAP1- terminal.
11	VOUT	Connect a capacitor between this terminal and the VSS
12	VSS	0V(GND)
13	VDD	+5.0V(Logic voltage)
14	D7(SI)	Serial data input
15	D6(SCL)	Serial clock input
16	/RD	Fixed to either "H" or to "L"
17	/WR	Fixed to either "H" or to "L"
18	A0	"H"=Display data , "L"=Control data
19	/RES	Reset signal
20	/CS1	Chip select signal

HANTRONIX, INC. 10080 BUBB RD. CUPERTINO, CA 95014	Q.A.:	REV.:	HDG12864F-1	SHEET 10 OF 21
	JK	1.2		DATE: 7/22/03

7. POWER SUPPLY/BOOSTER CAPACITANCE

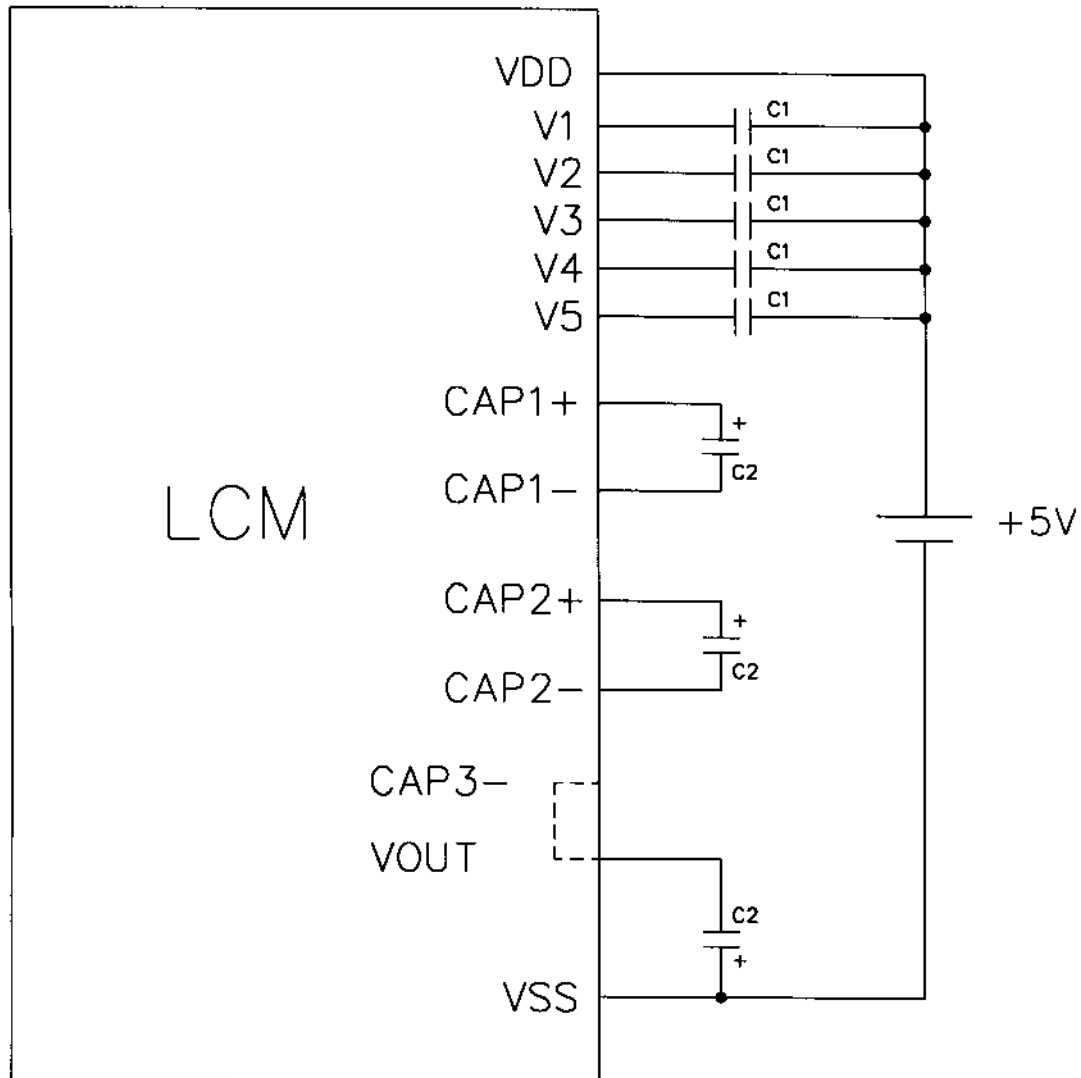

C1: 2.2~4.7 μ F
 C2: 2.2~4.7 μ F

HANTRONIX, INC. 10080 BUBB RD. CUPERTINO, CA 95014	Q.A.:	REV.:	HDG12864F-1	SHEET 11 OF 21
	JK	1.2		DATE:

8-1.SED1565 Series Commands

Command	Command Code										Function		
	A0	RD	WR	D7	D6	D5	D4	D3	D2	D1		D0	
(1)Display ON/OFF	0	1	0	1	0	1	0	1	1	1	0	LCD display ON/OFF 0: OFF,1: ON	
(2)Display start line set	0	1	0	0	1	Display start address					Sets the display RAM display start line address		
(3)Page address set	0	1	0	1	0	1	Page address					Sets the display RAM page address	
(4)Column address set upper bit	0	1	0	0	0	0	1	Most significant column address				Sets the most significant 4 bits of the display RAM column address.	
Column address set lower bit	0	1	0	0	0	0	0	Least significant column address				Sets the least significant 4 bits of the display RAM column address.	
(5)Status read	0	0	1	Status					0	0	0	0	Reads the status data
(6)Display data write	1	1	0	Write data								Writes to the display RAM	
(7)Display data read	1	0	1	Read data								Reads from the display RAM	
(8)ADC select	0	1	0	1	0	1	0	0	0	0	0	Sets the display RAM address SEG output correspondence 0: normal,1: reverse	
(9)Display normal/reverse	0	1	0	1	0	1	0	0	1	1	0	Sets the LCD display normal/reverse 0: normal,1: reverse	
(10)Display all points ON/OFF	0	1	0	1	0	1	0	0	1	0	0	Display all points 0: normal display 1: all point ON	
(11)LCD bias set	0	1	0	1	0	1	0	0	0	1	0	Sets the LCD drive voltage bias ratio SED1565***.....0: 1/9,1: 1/7 SED1566***.....0: 1/8,1: 1/6 SED1567***.....0: 1/6,1: 1/5	
(12)Read/modify/write	0	1	0	1	1	1	0	0	0	0	0	Column address increment At write: +1 At read: 0	
(13)End	0	1	0	1	1	1	0	1	1	1	0	Clear read/modify/write	
(14)Reset	0	1	0	1	1	1	0	0	0	1	0	Internal reset	
(15)Common output mode select	0	1	0	1	1	0	0	0	*	*	*	Select COM output scan direction 0: normal direction, 1: reverse direction	
(16)Power control set	0	1	0	0	0	1	0	1	Operating mode		Select internal power supply operating mode		
(17)V5 voltage regulator internal resistor ratio set	0	1	0	0	0	1	0	0	Resistor ratio		Select internal resistor ratio (Rb/Ra) mode		
(18)Electronic volume mode set	0	1	0	1	0	0	0	0	0	0	1	Set the V5 output voltage electronic volume register	
Electronic volume register set	0	1	0	*	*	Electronic volume value							
(19)Static indicator ON/OFF	0	1	0	1	0	1	0	1	1	0	0	0: OFF,1: ON	
Static indicator register set	0	1	0	*	*	*	*	*	*	*	mode	Set the flashing mode	
(20)Power saver												Display OFF and display all points ON compound command	
(21)NOP	0	1	0	1	1	1	0	0	0	1	1	Command for non-operation	
(22)Test	0	1	0	1	1	1	1	*	*	*	*	Command for IC test. Do not use this command	
(23)Test mode reset	0	1	0	1	1	1	1	0	0	0	0	Enter during the refresh sequence.	

(Note)*: disabled data

HANTRONIX, INC. 10080 BUBB RD. CUPERTINO, CA 95014	Q.A.:	REV.:	HDG12864F-1	SHEET 12 OF 21
	JK	1.2		DATE:

8-2.DISPLAY DATA RAM and ADDRESSES

Page Address	Data														Line address	COM output
0,0,0,0	D0														00H	COM0
	D1														01H	COM1
	D2														02H	COM2
	D3														03H	COM3
	D4														04H	COM4
	D5														05H	COM5
	D6														06H	COM6
	D7														07H	COM7
0,0,0,1	D0														08H	COM8
	D1														09H	COM9
	D2														0AH	COM10
	D3														0BH	COM11
	D4														0CH	COM12
	D5														0DH	COM13
	D6														0EH	COM14
	D7														0FH	COM15
0,0,1,0	D0														10H	COM16
	D7														17H	COM23
0,0,1,1	D0														18H	COM24
	D7														1FH	COM31
0,1,0,0	D0														20H	COM32
	D7														27H	COM39
0,1,0,1	D0														28H	COM40
	D7														2FH	COM47
0,1,1,0	D0														30H	COM48
	D1														31H	COM49
	D2														32H	COM50
	D3														33H	COM51
	D4														34H	COM52
	D5														35H	COM53
	D6														36H	COM54
	D7														37H	COM55
0,1,1,1	D0														38H	COM56
	D1														39H	COM57
	D2														3AH	COM58
	D3														3BH	COM59
	D4														3CH	COM60
	D5														3DH	COM61
	D6														3EH	COM62
	D7														3FH	COM63
1,0,0,0	D0														Page 8	COMS
Column address	ADC	00	01	02	03	04	05	06	07	---	---	---	---	---	---	---
	LCD	83	82	81	80	7F	7E	7D	7C	---	---	---	---	---	---	---
	OUT	00	01	02	03	04	05	06	07	---	---	---	---	---	---	---
		SEG0	SEG1	SEG2	SEG3	SEG4	SEG5	SEG6	SEG7	---	---	---	---	---	---	---
										SEG130	SEG131	---	---	---	---	---

when the common output mode is normal

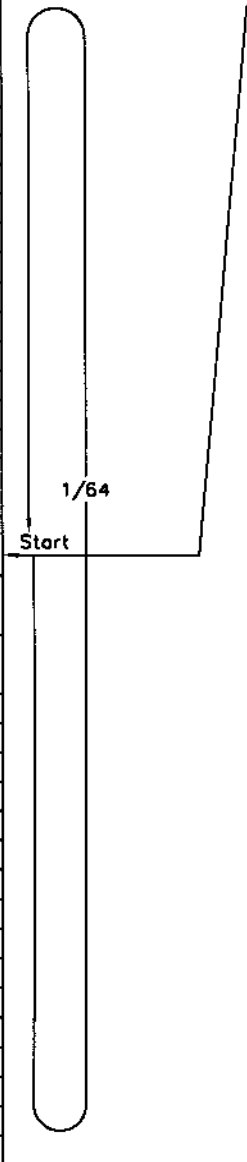

Downloaded from Elcodis.com electronic components distributor

8-3.DISPLAY PATTRN

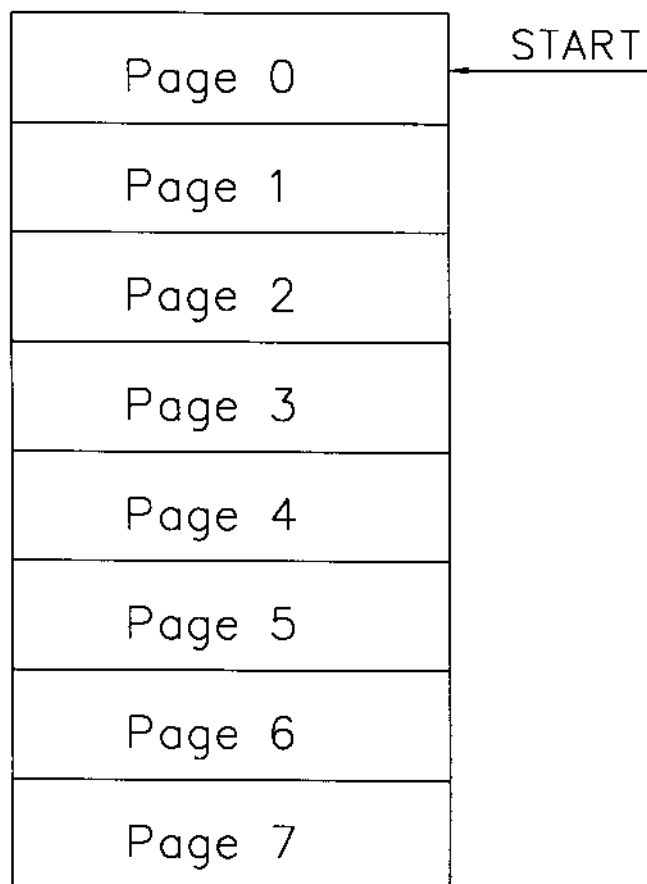

HANTRONIX, INC. 10080 BUBB RD. CUPERTINO, CA 95014	Q.A.: JK	REV.: 1.2	HDG12864F-1	SHEET 14 OF 21
				DATE: 7/22/03

9-1. TIMING CHARACTERISTICS

(For 6800 Series MPU)

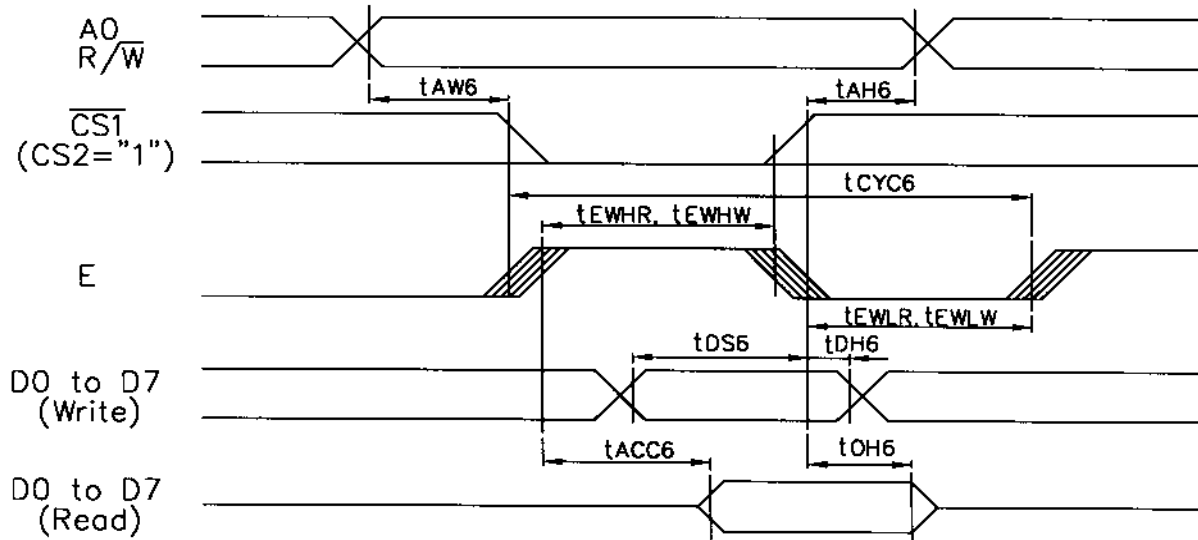

VDD=4.5~5.5V, Ta=-40~85°C

Item	Signal	Symbol	Condition	Rating		Unites
				Min	Max	
Address hold time	A0	tAH6		0	-	ns
Address setup time	A0	tAW6		0	-	ns
System cycle time	A0	tCYC6		166	-	ns
Data setup time	D0 to D7	tDS6		30	-	ns
Data hold time		tDH6		10	-	ns
Access time	D0 to D7	tACC6	CL=100pF	-	70	ns
Output disable time		tOH6		10	50	ns
Enable H pulse time	Read	E	tEWHR	70	-	ns
	Write	E	tEWHW	30	-	ns
Enable L pulse time	Read	E	tEWLR	30	-	ns
	Write	E	tEWLW	30	-	ns

VDD=2.7~4.5V, Ta=-40~85°C

Item	Signal	Symbol	Condition	Rating		Unites
				Min	Max	
Address hold time	A0	tAH6		0	-	ns
Address setup time	A0	tAW6		0	-	ns
System cycle time	A0	tCYC6		300	-	ns
Data setup time	D0 to D7	tDS6		40	-	ns
Data hold time		tDH6		15	-	ns
Access time	D0 to D7	tACC6	CL=100pF	-	140	ns
Output disable time		tOH6		10	100	ns
Enable H pulse time	Read	E	tEWHR	120	-	ns
	Write	E	tEWHW	60	-	ns
Enable L pulse time	Read	E	tEWLR	60	-	ns
	Write	E	tEWLW	60	-	ns

HANTRONIX, INC. 10080 BUBB RD. CUPERTINO, CA 95014	Q.A.:	REV.:	HDG12864F-1	SHEET 15 OF 21
	JK	1.2		DATE:

9-2. TIMING CHARACTERISTICS

(For 8080 Series MPU)

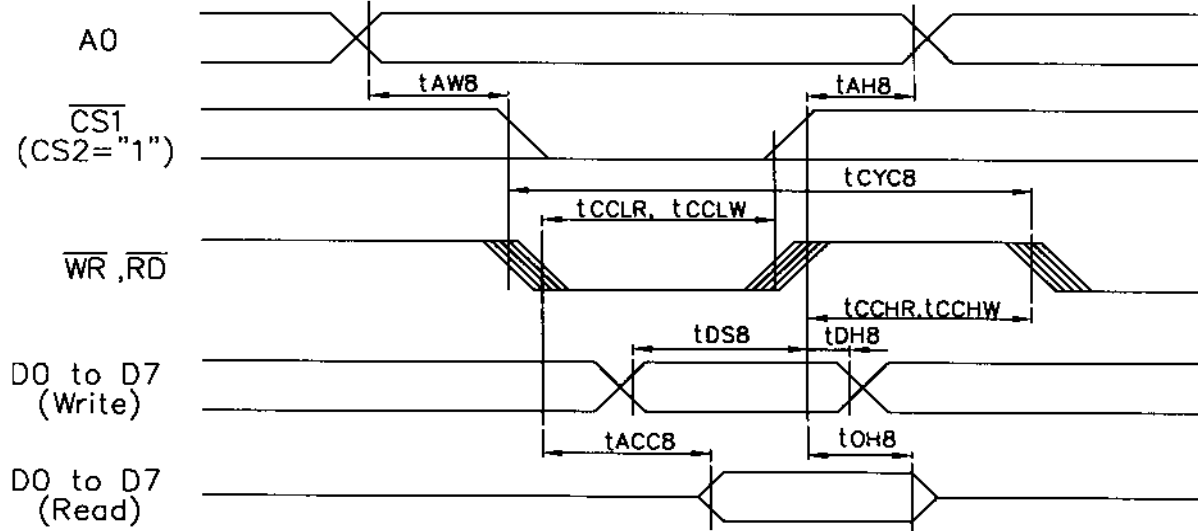

VDD=4.5~5.5V, To=-40~85°C

Item	Signal	Symbol	Condition	Rating		Unites
				Min	Max	
Address hold time	A0	tAH8		0	-	ns
Address setup time	A0	tAW8		0	-	ns
System cycle time	A0	tCYC8		166	-	ns
Control L pulse width	WR	tCCLW		30	-	ns
Control L pulse width	RD	tCCLR		70	-	ns
Control H pulse width	WR	tCCHW		30	-	ns
Control H pulse width	RD	tCCHR		30	-	ns
Data setup time	D0 to D7	tDS8		30	-	ns
Data hold time		tDH8		10	-	ns
RD access time	D0 to D7	tACC8	CL=100pF	-	70	ns
Output disable time		tOH8		5	50	ns

VDD=2.7~4.5V, To=-40~85°C

Item	Signal	Symbol	Condition	Rating		Unites
				Min	Max	
Address hold time	A0	tAH8		0	-	ns
Address setup time	A0	tAW8		0	-	ns
System cycle time	A0	tCYC8		300	-	ns
Control L pulse width	WR	tCCLW		60	-	ns
Control L pulse width	RD	tCCLR		120	-	ns
Control H pulse width	WR	tCCHW		60	-	ns
Control H pulse width	RD	tCCHR		60	-	ns
Data setup time	D0 to D7	tDS8		40	-	ns
Data hold time		tDH8		15	-	ns
RD access time	D0 to D7	tACC8	CL=100pF	-	140	ns
Output disable time		tOH8		10	100	ns

HANTRONIX, INC. 10080 BUBB RD. CUPERTINO, CA 95014	Q.A.:	REV.:	HDG12864F-1	SHEET 16 OF 21
	JK	1.2		DATE:

9-3. TIMING CHARACTERISTICS

(For Series Interface)

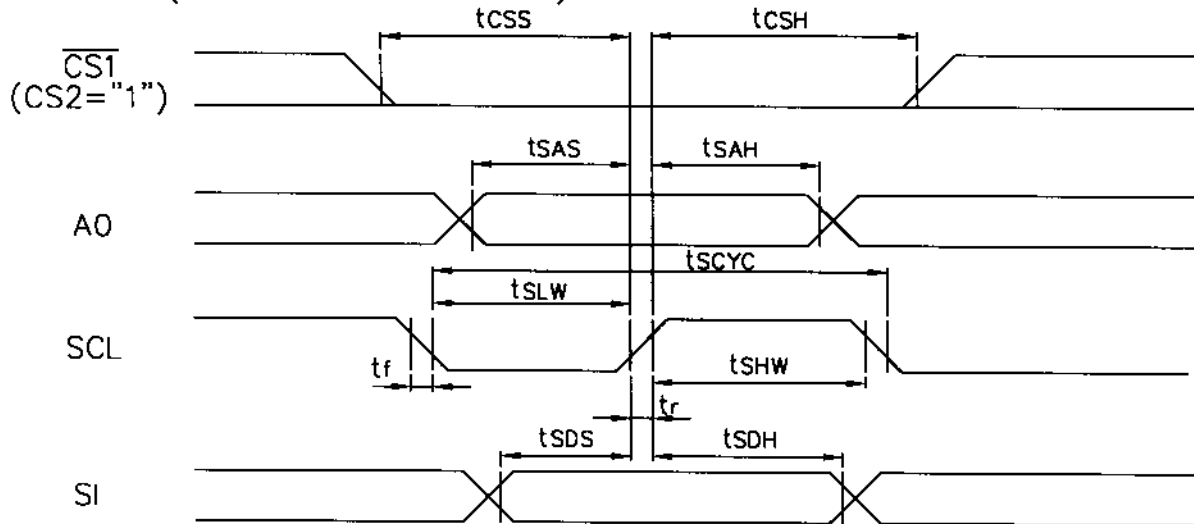

VDD=4.5~5.5V, Ta=-40~85°C

Item	Signal	Symbol	Condition	Rating		Unites
				Min	Max	
Serial Clock Period		tSCYC		200	-	ns
SCL "H" pulse width	SCL	tSHW		75	-	ns
SCL "L" pulse width	SCL	tSLW		75	-	ns
Address setup time	A0	tSAS		50	-	ns
Address hold time	A0	tSAH		100	-	ns
Data setup time	SI	tSDS		50	-	ns
Data hold time	SI	tSDH		50	-	ns
CS-SCL time	CS	tCSS		100	-	ns
		tCSH		100	-	ns

VDD=2.7~4.5V, Ta=-40~85°C

Item	Signal	Symbol	Condition	Rating		Unites
				Min	Max	
Serial Clock Period		tSCYC		250	-	ns
SCL "H" pulse width	SCL	tSHW		100	-	ns
SCL "L" pulse width	SCL	tSLW		100	-	ns
Address setup time	A0	tSAS		150	-	ns
Address hold time	A0	tSAH		150	-	ns
Data setup time	SI	tSDS		100	-	ns
Data hold time	SI	tSDH		100	-	ns
CS-SCL time	CS	tCSS		150	-	ns
		tCSH		150	-	ns

HANTRONIX, INC. 10080 BUBB RD. CUPERTINO, CA 95014	Q.A.:	REV.:	HDG12864F-1	SHEET 17 OF 21
	JK	1.2		DATE:

9-4. POWER ON/OFF TIMING

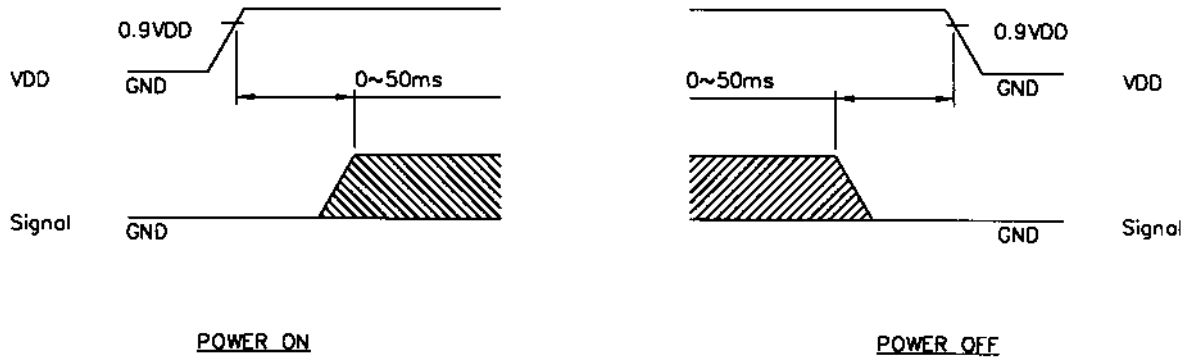

The missing pixels may occur when the LCM is driven beyond above power interface timing sequence.

HANTRONIX, INC. 10080 BUBB RD. CUPERTINO, CA 95014	Q.A.:	REV.:	HDG12864F-1	SHEET 18 OF 21
	JK	1.2		DATE: 7/22/03

10. RELIABILITY TEST

NO	ITEM	CONDITION			STANDARD	NOTE
1	High Temp. Storage	70°C	120HR		Appearance without defect	
2	Low Temp. Storage	-20°C	120HR		Appearance without defect	
3	High Temp. & High Humi. Storage	40°C 90%RH	120HR		Appearance without defect	
4	Thermal Shock	-20°C, 30min → 25°C.5min → 70°C, 30min → 25°C.5min (1cycle)			Appearance without defect	5 cycles

HANTRONIX, INC. 10080 BUBB RD. CUPERTINO, CA 95014	Q.A.:	REV.:	HDG12864F-1	SHEET 19 OF 21
	JK	1.2		DATE: 7/22/03

NOTICE:

- **SAFETY**

- 1.If the LCD panel breaks, be careful not to get the liquid crystal to touch your skin.
- 2.If the liquid crystal touches your skin or clothes, please wash it off immediately by using soap and water.

- **HANDLING**

- 1.Avoid static electricity which can damage the CMOS LSI.
- 2.Do not remove the panel or frame from the module.
- 3.The polarizing plate of the display is very fragile. So, please handle it very carefully.
- 4.Do not wipe the polarizing plate with a dry cloth, as it may easily scratch the surface of plate.
- 5.Do not use ketonics solvent & Aromatic solvent, use with a soft cloth soaked with a cleaning naphtha solvent.

- **STORAGE**

- 1.Store the panel or module in a dark place where the temperature is $25^{\circ}\text{C}\pm 5^{\circ}\text{C}$ and the humidity is below 65% RH.
- 2.Do not place the module near organics solvents or corrosive gases.
- 3.Do not crush, shake, or jolt the module.

- **TERMS OF WARRANT**

- 1.Acceptance inspection period
The period is within one month after the arrival of contracted commodity at the buyer's factory site.
- 2.Applicable warrant period
The period is within twelve months since the date of shipping out under normal using and storage conditions.

HANTRONIX, INC. 10080 BUBB RD. CUPERTINO, CA 95014	Q.A.: JK	REV.: 1.2	HDG12864F-1	SHEET 20 OF 21
				DATE: 7/22/03

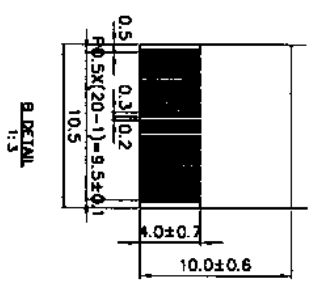
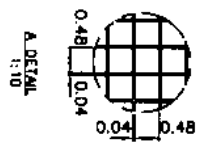
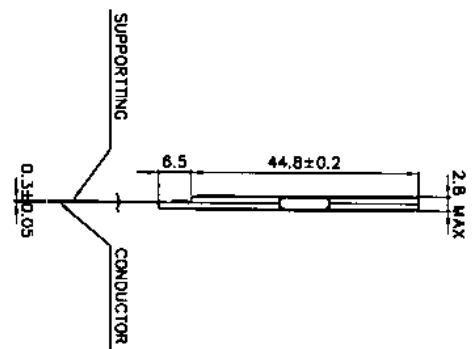
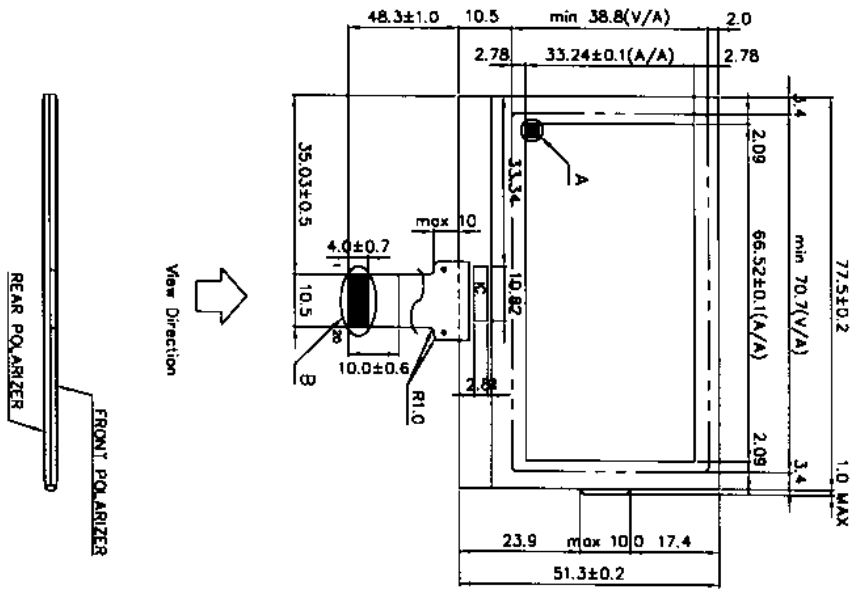

Note:
 1. RESOLUTION : 128X64
 2. COG IC : SED1565
 3. GLASS THICKNESS : 1.1 mm
 4. GENERAL TOLERANCE: ±0.2mm

HANTRONIX, INC. 10080 BUBB RD. CUPERTINO, CA 95014	Q.A.:	REV.:	HDG12864F-1	SHEET 21 OF 21
	JK	1.2		DATE: