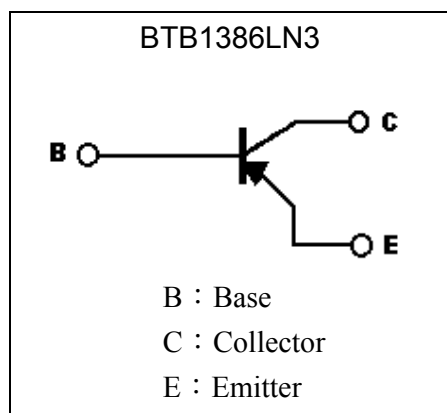
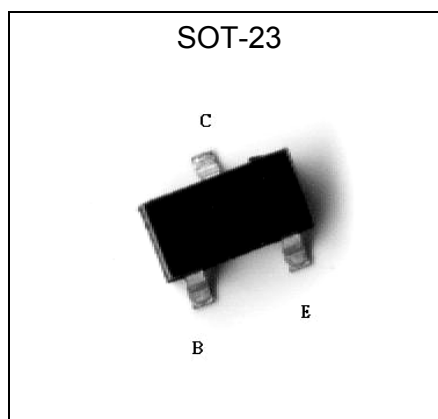

Low Vcesat PNP Epitaxial Planar Transistor

BTB1386LN3

Features

- Low $V_{CE(sat)}$, $V_{CE(sat)} = -0.6$ V (typical), at $I_C / I_B = -4A / -0.1A$
- Excellent DC current gain characteristics
- Complementary to BTB2098LN3

Symbol

Outline

Absolute Maximum Ratings ($T_a = 25^\circ\text{C}$)

| Parameter | Symbol | Limits | Unit |
|---|-----------------|-------------|---------------------------|
| Collector-Base Voltage | V_{CBO} | -20 | V |
| Collector-Emitter Voltage | V_{CEO} | -15 | V |
| Emitter-Base Voltage | V_{EBO} | -6 | V |
| Collector Current | $I_C(DC)$ | -5 | A |
| | $I_C(Pulse)$ | -10 (Note) | |
| Power Dissipation | P_D | 225 | mW |
| Thermal Resistance, Junction to Ambient | $R_{\theta JA}$ | 556 | $^\circ\text{C}/\text{W}$ |
| Junction Temperature | T_j | 150 | $^\circ\text{C}$ |
| Storage Temperature | T_{stg} | -55~+150 | $^\circ\text{C}$ |

 Note : 1. Single Pulse $P_w \leq 350\mu\text{s}$, Duty $\leq 2\%$.

**Characteristics (Ta=25°C)**

| Symbol | Min. | Typ. | Max. | Unit | Test Conditions |
|-----------------|------|------|------|---------|----------------------------------|
| BV_{CBO} | -20 | - | - | V | $I_C=-50\mu A, I_E=0$ |
| BV_{CEO} | -15 | - | - | V | $I_C=-1mA, I_B=0$ |
| BV_{EBO} | -6 | - | - | V | $I_E=-50\mu A, I_C=0$ |
| I_{CBO} | - | - | -0.5 | μA | $V_{CB}=-15V, I_E=0$ |
| I_{EBO} | - | - | -0.5 | μA | $V_{EB}=-5V, I_C=0$ |
| * $V_{CE(sat)}$ | - | - | -1.0 | V | $I_C=-4A, I_B=-0.1A$ |
| * h_{FE} | 120 | - | 560 | - | $V_{CE}=-2V, I_C=-0.5A$ |
| f_T | - | 120 | - | MHz | $V_{CE}=-6V, I_C=-50mA, f=30MHz$ |
| Cob | - | 60 | - | pF | $V_{CB}=-20V, f=1MHz$ |

*Pulse Test : Pulse Width $\leq 380\mu s$, Duty Cycle $\leq 2\%$ **Classification Of h_{FE}**

| Rank | Q | R | S |
|-------|---------|---------|---------|
| Range | 120~270 | 180~390 | 270~560 |



Characteristic Curves

Current Gain vs Collector Current

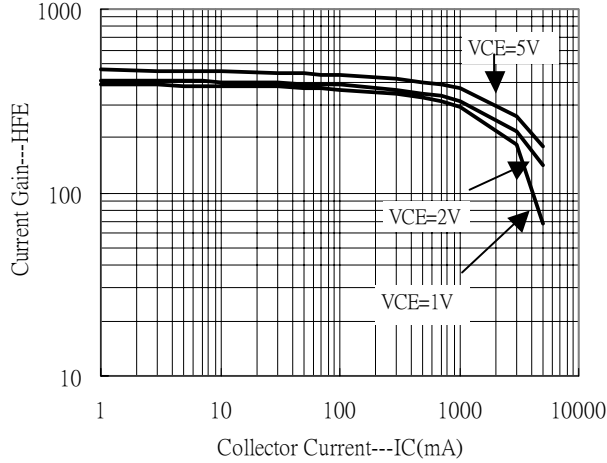

Saturation Voltage vs Collector Current

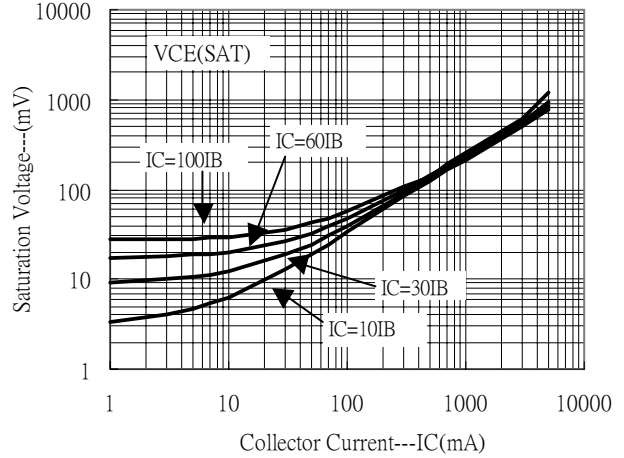

Saturation Voltage vs Collector Current

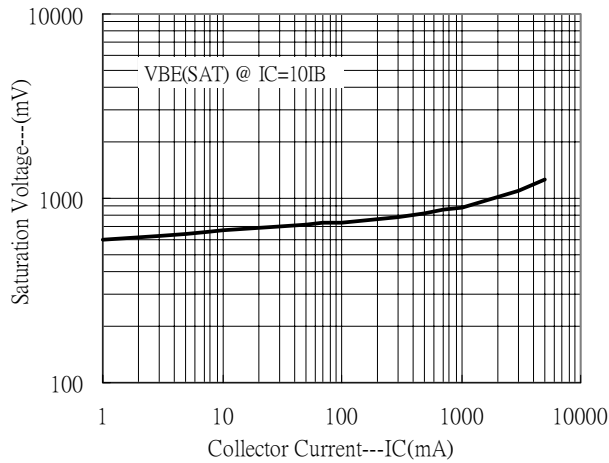

Power Derating Curve

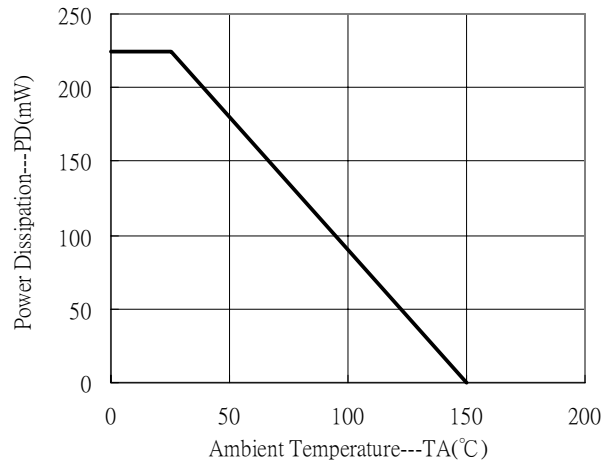

SOT-23 Dimension

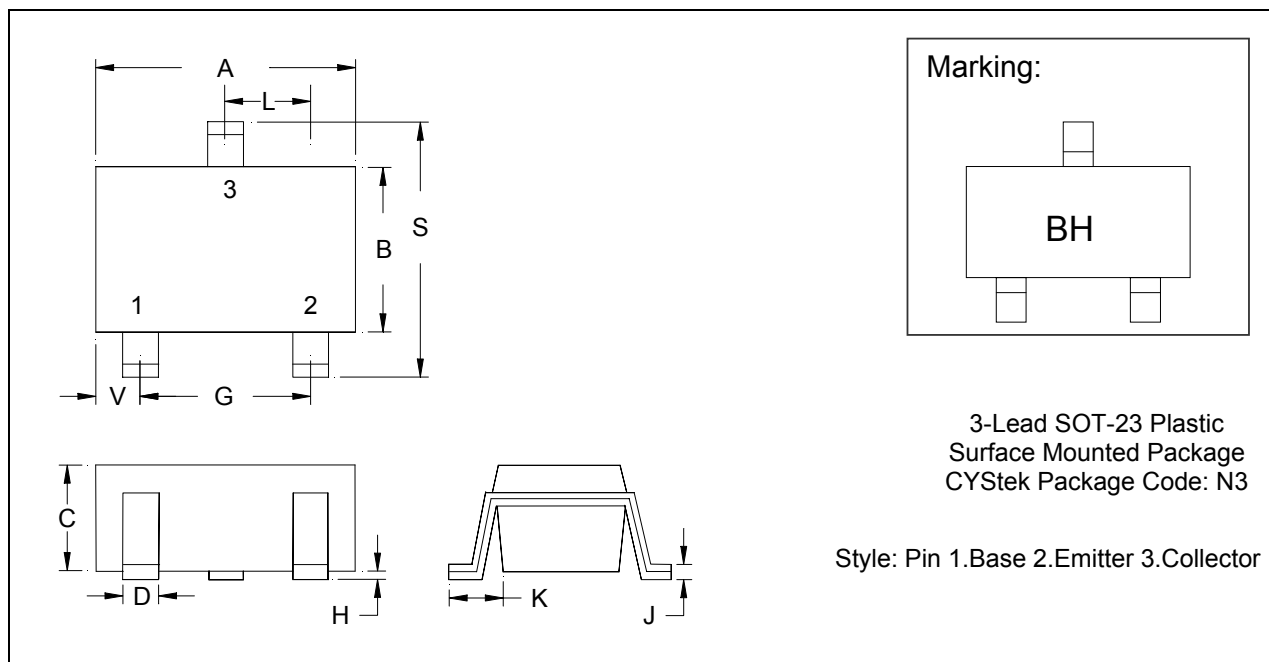

*: Typical

| DIM | Inches | | Millimeters | | DIM | Inches | | Millimeters | |
|-----|--------|--------|-------------|------|-----|--------|--------|-------------|-------|
| | Min. | Max. | Min. | Max. | | Min. | Max. | Min. | Max. |
| A | 0.1102 | 0.1204 | 2.80 | 3.04 | J | 0.0034 | 0.0070 | 0.085 | 0.177 |
| B | 0.0472 | 0.0630 | 1.20 | 1.60 | K | 0.0128 | 0.0266 | 0.32 | 0.67 |
| C | 0.0335 | 0.0512 | 0.89 | 1.30 | L | 0.0335 | 0.0453 | 0.85 | 1.15 |
| D | 0.0118 | 0.0197 | 0.30 | 0.50 | S | 0.0830 | 0.1083 | 2.10 | 2.75 |
| G | 0.0669 | 0.0910 | 1.70 | 2.30 | V | 0.0098 | 0.0256 | 0.25 | 0.65 |
| H | 0.0005 | 0.0040 | 0.013 | 0.10 | | | | | |

Notes: 1.Controlling dimension: millimeters.
 2.Maximum lead thickness includes lead finish thickness, and minimum lead thickness is the minimum thickness of base material.
 3.If there is any question with packing specification or packing method, please contact your local CYStek sales office.

Material:

- Lead: 42 Alloy ; solder plating
- Mold Compound: Epoxy resin family, flammability solid burning class: UL94V-0

Important Notice:

- All rights are reserved. Reproduction in whole or in part is prohibited without the prior written approval of CYStek.
- CYStek reserves the right to make changes to its products without notice.
- CYStek **semiconductor products are not warranted to be suitable for use in Life-Support Applications, or systems.**
- CYStek assumes no liability for any consequence of customer product design, infringement of patents, or application assistance.