

**Low-Dropout, Constant-Current  
White LED with Channel Control****FEATURES**

- Up to 400mA LED Bias Current
- 3% LED Current Matching
- Simple LED Brightness Control
- Low 0.05uA Shutdown Current
- 3V to 5.5V Supply Voltage Range
- MSOP-10L Package
- Output channel :  
MSOP-10L package for four channel
- LED1~4 Channels ON / OFF states:  
T6326A-AM with 16 channel states  
T6326A-BM with 5 channel states
- Build in Thermal Protect 140 °C

**Applications**

- Cellular Phones
- Portable Communication Devices
- Handheld Electronics
- Digital Cameras
- PDAs
- LED/Display Back Light Driver
- LEDs for Camera Flash

**PART NUMBER EXAMPLES**

<b>PART NO.</b>	<b>PACKAGE</b>	<b>ON states</b>
T6326A-AM	MSOP-10L	16
T6326A-BM	MSOP-10L	5

**GRNERAL DESCRIPTION**

The T6326A low-dropout bias supply for white LEDs is a high-performance alternative to the simple ballast resistors used in conventional white LED designs. The T6326A with internal channel on/off select function. The T6326A uses a single resistor to set the bias current for four LEDs, which are matched to 3%. The T6326A advantages over ballast resistors include significantly better LED to LED bias matching, much lower bias variation with supply voltage variation, significantly lower dropout voltage, and in some applications, significantly improved efficiency. The T6326A is available in MSOP-10L package.

**PIN ARRANGEMENT(Top view)**

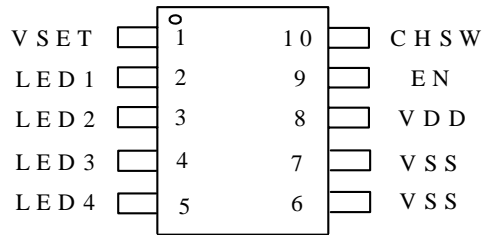

MSOP-10L

**PIN DESCRIPTION**

SYMBOL	MSOP-10L	DESCRIPTION
VSET	1	VSET terminal is used to connect an external resistor to set output current. The current flowing into VSET sets the bias current into each LED by $I_{LED\_} = 250 \times I_{SET}$ . VSET is internally biased to 0.306V. VSET is high impedance when EN is low.
LED1	2	LED 1 Cathode Connection. Current flowing into LED1 is 250 times the current flowing into SET. LED1 is high impedance when EN is low.
LED2	3	LED 2 Cathode Connection. Current flowing into LED1 is 250 times the current flowing into SET. LED2 is high impedance when EN is low.
LED3	4	LED 3 Cathode Connection. Current flowing into LED1 is 250 times the current flowing into SET. LED3 is high impedance when EN is low.
LED4	5	LED 4 Cathode Connection. Current flowing into LED1 is 250 times the current flowing into SET. LED4 is high impedance when EN is low.
VSS	6,7	Ground
VDD	8	Power supply
EN	9	Enables T6326A signal, H: Active, L : Power Down .
CHSW	10	Set LED1~4 Channels ON / OFF, the rising edge of CHSW will change next states.

**ABSOLUTE MAXIMUM RATINGS**

Parameter	Symbol	Value	Unit
Voltage on any pin relative to GND	V <sub>IN</sub>	-0.3 to 6	V
Operating Temperature Rang	T <sub>A</sub>	-40 to +85	°C
Maximum Soldering Temperature (at leads, 10 sec)	T <sub>LEAD</sub>	300	°C
Storage Temperature Rang	T <sub>S</sub>	-65 to +150	°C
Continuous Power Dissipation ( T <sub>A</sub> = +70°C )		1	W

**Electrical Characteristics**

(T<sub>A</sub> = -40 to 85°C unless otherwise noted. Typical values are at T<sub>A</sub> =25°C,  
V<sub>EN</sub> =3.3V, V<sub>LED1</sub> = V<sub>LED2</sub>= V<sub>LED3</sub>= V<sub>LED4</sub>= 1V)

Symbol	Description	Conditions	Min.	Typ.	Max	Unit
V <sub>EN</sub>	Operating voltage range	EN is power supply input	3		5.5	V
I <sub>SET</sub>	SET input current range			1400	1600	uA
I <sub>SETR</sub>	SET to LED current ratio	I <sub>LED</sub> / I <sub>SET</sub> , I <sub>SET</sub> =400uA		250		A/A
V <sub>SET</sub>	SET bias voltage	I <sub>SET</sub> =400uA		0.306		V
I <sub>CM</sub>	LED to LED current matching	I <sub>SET</sub> =400uA		3		%
I <sub>LED</sub>	Maximum LED sink current	Each LED		350	400	mA
I <sub>LSD</sub>	LED leakage current in shutdown	V <sub>LED1</sub> =V <sub>LED2</sub> =V <sub>LED3</sub> =V <sub>LED4</sub> = 3.3V, EN=GND, T <sub>A</sub> =+25°C, each LED		0.01	1	uA
V <sub>IH</sub>	Input high voltage	V <sub>EN</sub> >V <sub>IH</sub> for enable, V <sub>DD</sub> =5V	2.5			V
V <sub>IL</sub>	Input low voltage	V <sub>EN</sub> <V <sub>IL</sub> for disable, V <sub>DD</sub> =5V			2.2	V
T <sub>TP</sub>	Thermat Protect			140		°C

## Functional Description

The T6326A provides constant current bias supply for white LED designs. The T6326A uses a single resistor to set the bias current for up to three LEDs. LED bias currents are matched to 3% by the T6326A current matching architecture (Fig. 1). The T6326A offers several advantages over using ballast resistors, such as improved LED to LED brightness matching, lower bias variation with supply voltage changes, significantly lower dropout voltage, and in some applications, significantly improved efficiency.

### Enable Input

EN powers the input of the T6326A. Drive EN high (> 2.5V) to enable the device; drive EN low (< 2.2V) to disable the device. Driving EN low forces LED1, LED2, LED3, LED4 and SET into a high-impedance state.

### CHSW Input

The Set LED1~4 Channels ON / OFF , the rising edge of CHSW will change next states. The T6326A with Internal SEL pad Channel function select.

The T6326A-AM with 16 channel states:  
LED[1:4]=[1111],[1110],[1101],[1100],  
[1011],[1010],[1001],[1000],  
[0111],[0110],[0101],[0100],  
[0011],[0010],[0001],[0000]

The T6326A-BM with 5 channel states :  
LED[1:4]=[1111],[1110],[1100],[1000],[0000]

### Setting the Output Current

SET controls the LED bias current. Current flowing into LED1, LED2, LED3 and LED4 is 250 times greater than the current flowing into SET. Set the output current as follows:

$$I_{LED} = 250 (V_{SET} / R_{SET})$$

$$V_{SET} = 0.306V$$

## Applications Information

Very Low-Cost, High-Efficiency Solution .  
A battery (single Li+ or three NiMH cells) powers the LEDs directly. This is the least expensive and most efficient architecture. Due to the high forward voltage of white LEDs, the LED brightness may dim slightly at the end of battery life. The T6326A current regulating architecture and low dropout greatly minimize this effect compared to using simple ballast resistors. The enable function of the T6326A turns on and off the LEDs.

**TYPICAL APPLICATION CIRCUITS**

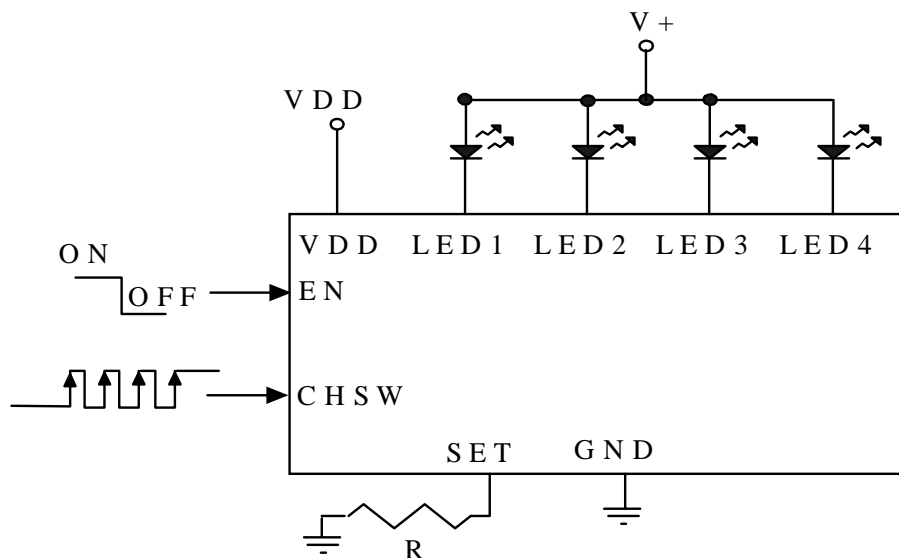

Very low-cost, high-efficiency solution

**PACKAGE DIMENSIONS  
10-LEAD MSOP-10L**

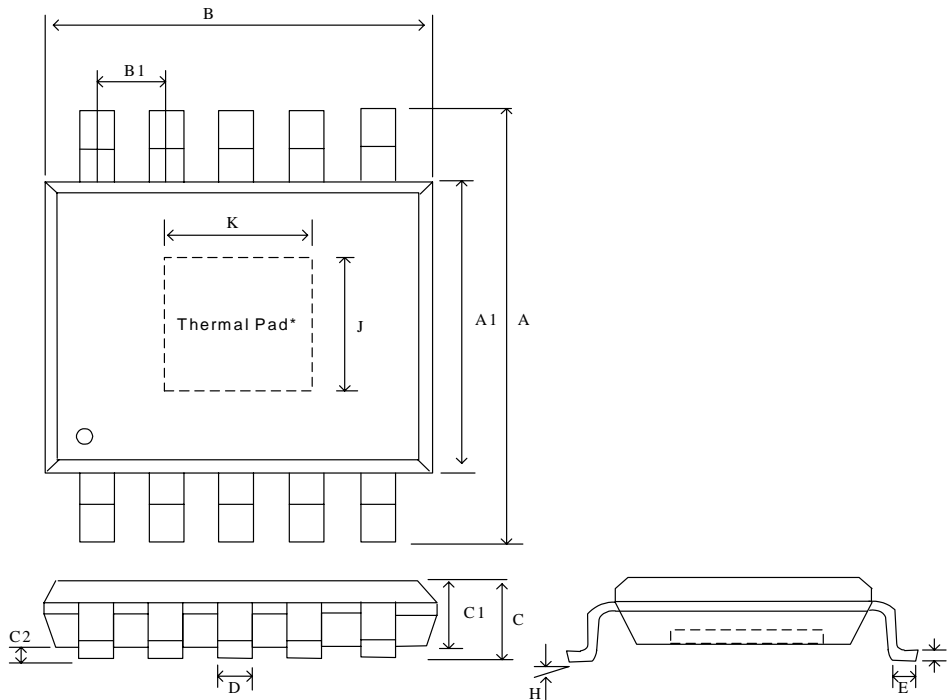

Symbol	Dimension in mm			Dimension in inch		
	Min.	Typ.	Max.	Min.	Typ.	Max.
A	-	4.90	-	-	0.193	-
A1	-	3.00	-	-	0.118	-
B	-	3.00	-	-	0.118	-
B1	-	0.50	-	-	0.019	-
C	-	-	1.10	-	-	0.043
C1	0.75	0.85	0.95	0.029	0.033	0.037
C2	0.00	-	0.15	0.000	-	0.006
D	0.17	-	0.27	0.007	-	0.010
E	0.40	0.60	0.80	0.015	0.024	0.031
F	0.10	0.15	0.25	0.004	0.006	0.010
J	-	1.715 REF	-	-	0.067 REF	-
K	-	1.600 REF	-	-	0.063 REF	-
H	0~8°			0~8°		

**\*Note :**

The thermal pad on the IC's bottom has to be mounted on the copper foil.

To eliminate the noise influence, the thermal pad is suggested to be connected to GND on PCB.

In addition, desired thermal conductivity will be improved, if a heat-conducting copper foil on PCB is soldered with thermal pad. The thermal pad enhances the power dissipation. As a result, a large amount of current can be sunk safely in one package.