

International
IOR Rectifier

80RIA SERIES

PHASE CONTROL THYRISTORS

Stud Version

Features

- Hermetic glass-metal seal
- International standard case TO-209AC (TO-94)

80A

Typical Applications

- DC motor controls
- Controlled DC power supplies
- AC controllers

Major Ratings and Characteristics

Parameters	80RIA	Unit
$I_{T(AV)}$	80	A
@ T_C	85	°C
$I_{T(RMS)}$	125	A
I_{TSM} @ 50Hz	1900	A
@ 60Hz	1990	A
I^2t @ 50Hz	18	KA ² s
@ 60Hz	16	KA ² s
V_{DRM}/V_{RRM}	400 to 1200	V
t_q typical	110	μs
T_J	- 40 to 125	°C

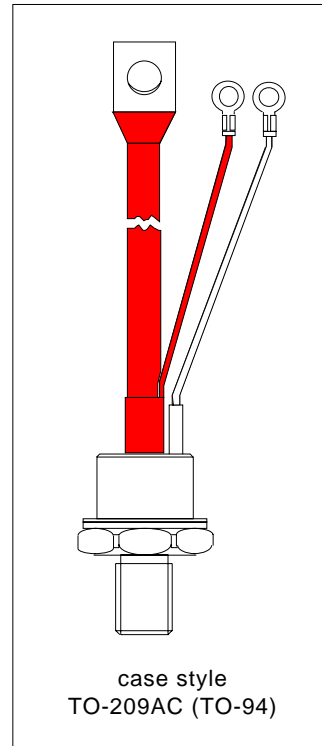

ELECTRICAL SPECIFICATIONS

Voltage Ratings

Type number	Voltage Code	V_{DRM}/V_{RRM} , max. repetitive peak and off-state voltage V	V_{RSM} , maximum non-repetitive peak voltage V	I_{DRM}/I_{RRM} max. @ $T_J = 125^\circ\text{C}$ mA
80RIA	40	400	500	15
	80	800	900	
	120	1200	1300	

On-state Conduction

Parameter	80RIA	Units	Conditions
$I_{T(AV)}$ Max. average on-state current @ Case temperature	80	A	180° conduction, half sine wave
	85	°C	
$I_{T(RMS)}$ Max. RMS on-state current	125	A	DC @ 75°C case temperature
I_{TSM} Max. peak, one-cycle non-repetitive surge current	1900	A	t = 10ms No voltage
	1990		t = 8.3ms reapplied
	1600		t = 10ms 100% V_{RRM}
	1675		t = 8.3ms reapplied
I^2t Maximum I^2t for fusing	18	KA ² s	t = 10ms No voltage
	16		t = 8.3ms reapplied
	12.7		t = 10ms 100% V_{RRM}
	11.7		t = 8.3ms reapplied
$I^2\sqrt{t}$ Maximum $I^2\sqrt{t}$ for fusing	180.5	KA ² √s	t = 0.1 to 10ms, no voltage reapplied
$V_{T(TO)1}$ Low level value of threshold voltage	0.99	V	$(16.7\% \times \pi \times I_{T(AV)} < I < \pi \times I_{T(AV)})$, $T_J = T_J \text{ max.}$
$V_{T(TO)2}$ High level value of threshold voltage	1.13		$(I > \pi \times I_{T(AV)})$, $T_J = T_J \text{ max.}$
r_{t1} Low level value of on-state slope resistance	2.29	mΩ	$(16.7\% \times \pi \times I_{T(AV)} < I < \pi \times I_{T(AV)})$, $T_J = T_J \text{ max.}$
r_{t2} High level value of on-state slope resistance	1.84		$(I > \pi \times I_{T(AV)})$, $T_J = T_J \text{ max.}$
V_{TM} Max. on-state voltage	1.60	V	$I_{pk} = 250\text{A}$, $T_J = 25^\circ\text{C}$ $t_p = 10\text{ms}$ sine pulse
I_H Maximum holding current	200	mA	$T_J = 25^\circ\text{C}$, anode supply 12V resistive load
I_L Typical latching current	400		

Switching

Parameter	80RIA	Units	Conditions
di/dt Max. non-repetitive rate of rise of turned-on current	300	A/μs	T _J = 125°C, V _d = rated V _{DRM} , I _{TM} = 2xdi/dt snubber 0.2μF, 15Ω, Gate pulse: 20V, 65Ω, t _p = 6μs, t _r = 0.5μs Per JEDEC Standard RS-397, 5.2.2.6.
t _d Typical delay time	1	μs	Gate pulse: 10V, 15Ω source, t _p = 6μs, t _r = 0.1μs, V _d = rated V _{DRM} , I _{TM} = 50A, T _J = 25°C.
t _q Typical turn-off time	110		I _{TM} = 50A, T _J = T _J max, di/dt = -5A/μs min., V _R = 50V, dv/dt = 20V/μs, Gate bias: 0V 25Ω, t _p = 500μs

Blocking

Parameter	80RIA	Units	Conditions
dv/dt Maximum critical rate of rise of off-state voltage	500	V/μs	T _J = 125°C exponential to 67% rated V _{DRM}
I _{RRM} I _{DRM} Max. peak reverse and off-state leakage current	15	mA	T _J = 125°C rated V _{DRM} /V _{RRM} applied

Triggering

Parameter	80RIA	Units	Conditions
P _{GM} Maximum peak gate power	12	W	T _J = T _J max, t _p ≤ 5ms
P _{G(AV)} Maximum average gate power	3		T _J = T _J max, f = 50Hz, d% = 50
I _{GM} Max. peak positive gate current	3	A	T _J = T _J max, t _p ≤ 5ms
+V _{GM} Maximum peak positive gate voltage	20	V	T _J = T _J max, t _p ≤ 5ms
-V _{GM} Maximum peak negative gate voltage	10		
I _{GT} Max. DC gate current required to trigger	270	mA	T _J = - 40°C
	120		T _J = 25°C
	60		T _J = 125°C
V _{GT} Max. DC gate voltage required to trigger	3.5	V	T _J = - 40°C
	2.5		T _J = 25°C
	1.5		T _J = 125°C
I _{GD} DC gate current not to trigger	6	mA	Max. required gate trigger/ current/ voltage are the lowest value which will trigger all units 6V anode-to-cathode applied
V _{GD} DC gate voltage not to trigger	0.25		

80RIA Series

Bulletin I25201 rev. B 03/03

International
 Rectifier

Thermal and Mechanical Specification

Parameter	80RIA	Units	Conditions
T _J Max. operating temperature range	-40 to 125	°C	
T _{stg} Max. storage temperature range	-40 to 150		
R _{thJC} Max. thermal resistance, junction to case	0.30	K/W	DC operation
R _{thCS} Max. thermal resistance, case to heatsink	0.1		Mounting surface, smooth, flat and greased
T Mounting torque, ± 10%	15.5 (137)	Nm (lbf-in)	Non lubricated threads
	14 (120)		Lubricated threads
wt Approximate weight	130	g	
Case style	TO-209AC(TO-94)		See Outline Table

ΔR_{thJ-C} Conduction

(The following table shows the increment of thermal resistance R_{thJ-C} when devices operate at different conduction angles than DC)

Conduction angle	Sinusoidal conduction	Rectangular conduction	Units	Conditions
180°	0.042	0.030	K/W	T _J = T _J max.
120°	0.050	0.052		
90°	0.064	0.070		
60°	0.095	0.100		
30°	0.164	0.165		

Ordering Information Table

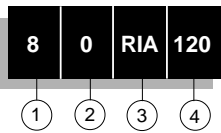
Device Code	
	
1	- I _{TAV} x 10A
2	- 0 = Eyelet terminals (Gate and Auxiliary Cathode Leads) 1 = Fast - on terminals (Gate and Auxiliary Cathode Leads)
3	- RIA = Essential part number
4	- Voltage code: Code x 10 = V _{RRM} (See Voltage Rating Table)
5	- None = Stud base 1/2"-20UNF- 2A threads
NOTE: For Metric Device M12 x 1.75 E6 Contact factory	

Outline Table

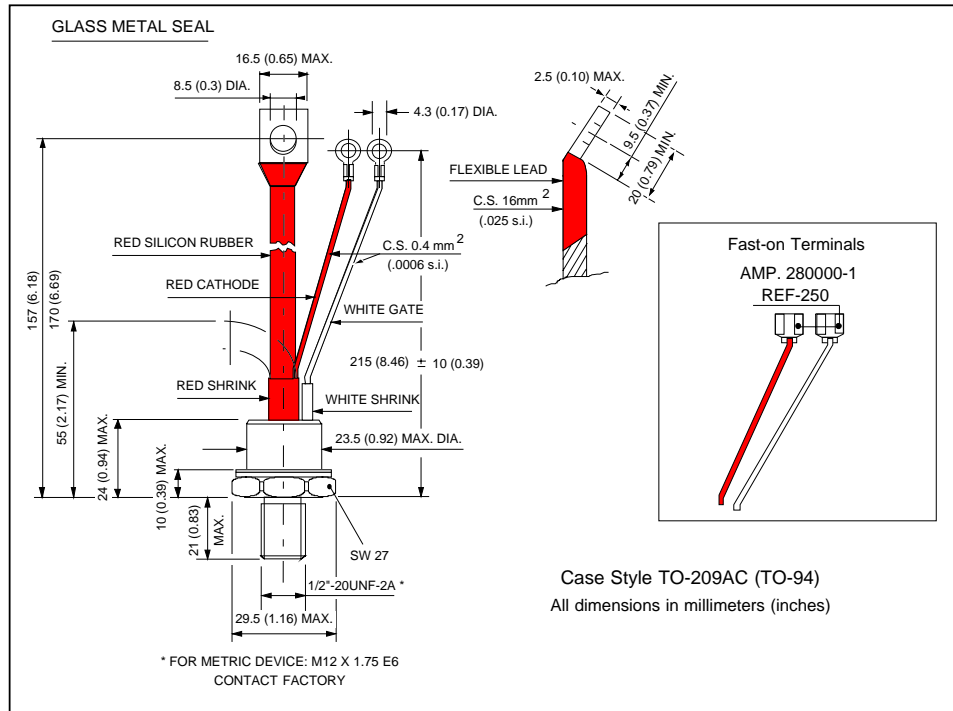

Case Style TO-209AC (TO-94)
 All dimensions in millimeters (inches)

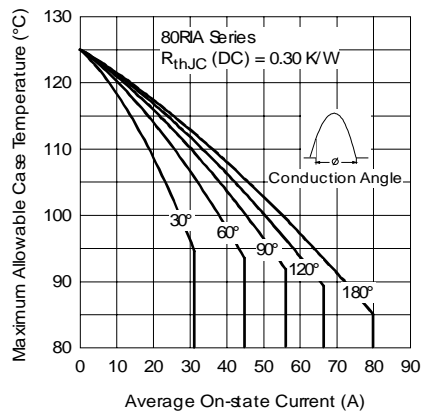

Fig. 1 - Current Ratings Characteristics

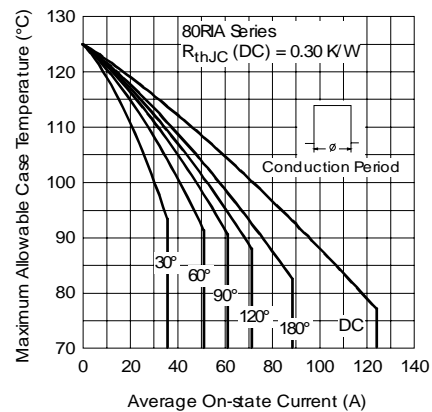

Fig. 2 - Current Ratings Characteristics

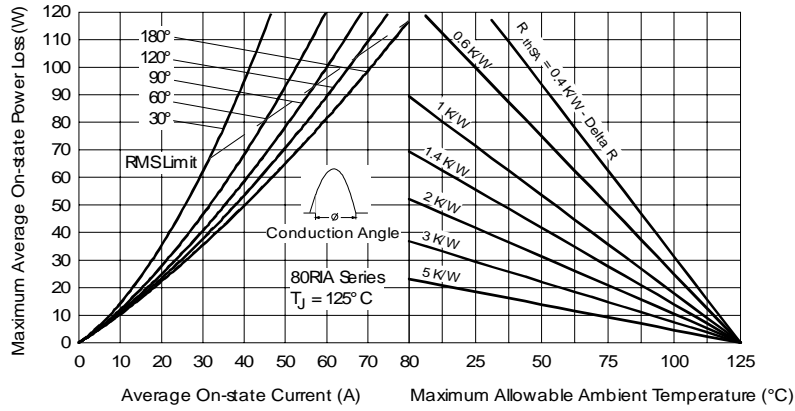

Fig. 3 - On-state Power Loss Characteristics

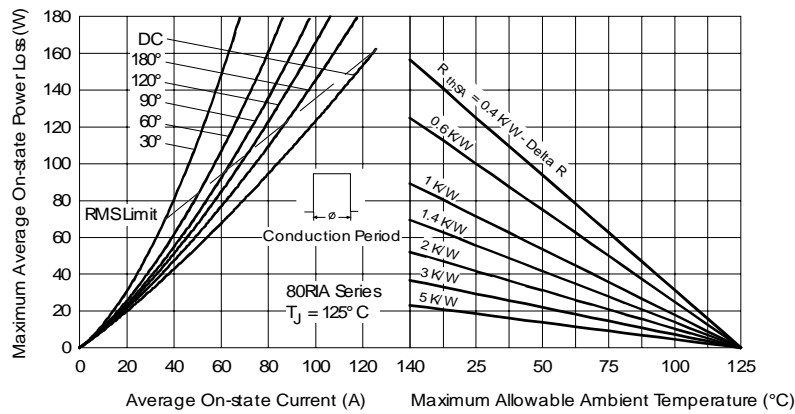

Fig. 4 - On-state Power Loss Characteristics

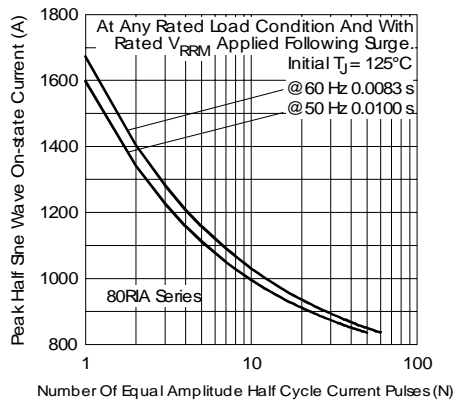

Fig. 5 - Maximum Non-Repetitive Surge Current

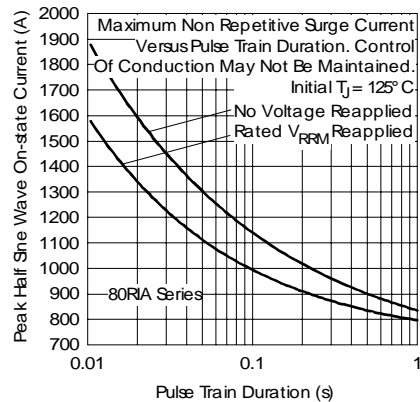

Fig. 6 - Maximum Non-Repetitive Surge Current

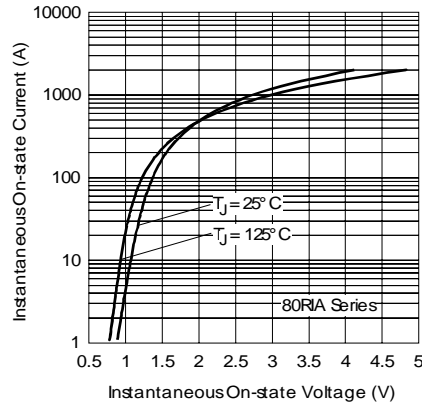

Fig. 7 - On-state Voltage Drop Characteristics

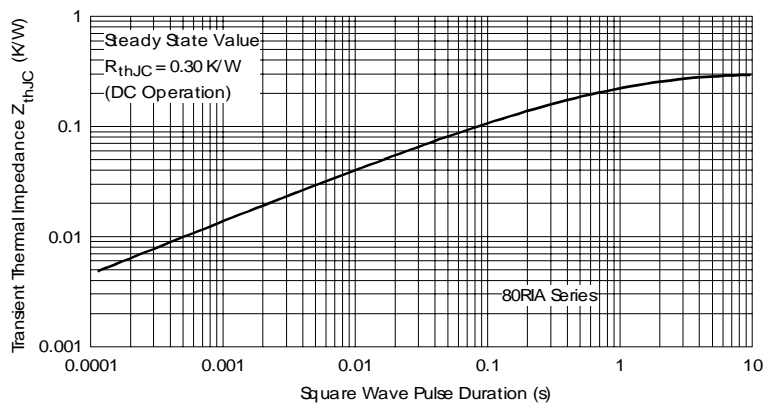

Fig. 8 - Thermal Impedance Z_{thJC} Characteristics

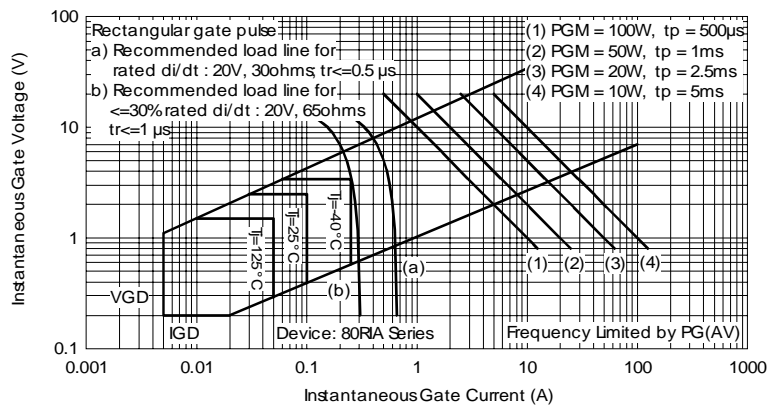

Fig. 9 - Gate Characteristics

80RIA Series

Bulletin I25201 rev. B 03/03

International
IOR Rectifier

Data and specifications subject to change without notice.
This product has been designed and qualified for Industrial Level.
Qualification Standards can be found on IR's Web site.

International
IOR Rectifier

IR WORLD HEADQUARTERS: 233 Kansas St., El Segundo, California 90245, USA Tel: (310) 252-7105
TAC Fax: (310) 252-7309
Visit us at www.irf.com for sales contact information. 03/03