

## VOLTAGE DETECTOR

### ■ GENERAL DESCRIPTION

The NJU7700/01 is a high precision and low quiescent current voltage detector.

The detection voltage is internally fixed with an accuracy of 1.0%.

The NJU7700/01 are useful for preventing malfunction of microcomputer or DSP etc. through detect a drop in voltage of battery or power supply.

NJU7700 is Nch. Open Drain and NJU7701 is a C-MOS output type.

Small packaging makes NJU7700 and NJU7701 suitable for space conscious applications.

### ■ PACKAGE OUTLINE

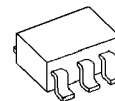

NJU7700/01F



NJU7700/01F4

### ■ FEATURES

- High Precision Detection Voltage       $\pm 1.0\%$
- Low Quiescent Current                   $0.8\mu\text{A typ. (}V_{\text{DET}}=3\text{V version)}$
- Detection Voltage Range                 $1.3\text{--}6.0\text{V}(0.1\text{V Step)}$
- Output Configuration  
     NJU7700: Nch. Open Drain type  
     NJU7701: C-MOS Output type
- CMOS Technology
- Package Outline  
     SOT-23-5 : NJU7700/01F  
     SC-82AB : NJU7700/01F4

### ■ PIN CONFIGURATION

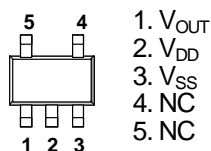

NJU7700/01F

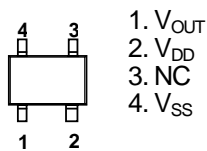

NJU7700/01F4

### ■ EQUIVALENT CIRCUIT

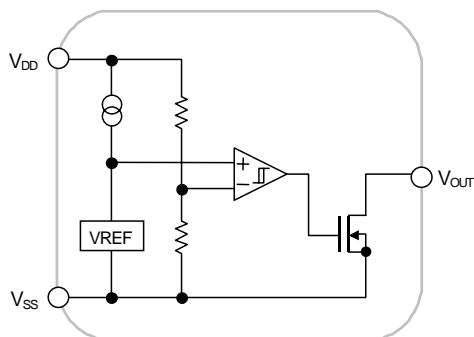

NJU7700

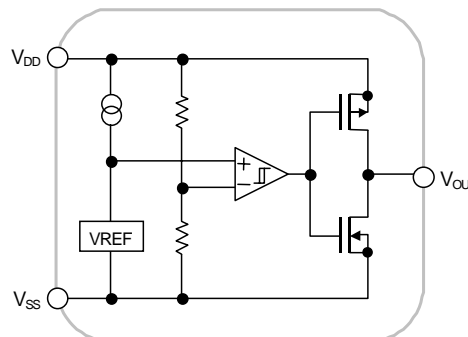

NJU7701

# NJU7700/01

## DETECTION VOLTAGE RANK LIST

Device Name	V <sub>DET</sub>	Device Name	V <sub>DET</sub>	Device Name	V <sub>DET</sub>	Device Name	V <sub>DET</sub>
NJU770*F4-/F13	1.3V	NJU770*F4-/F23	2.3V	NJU770*F4-/F32	3.2V	NJU770*F4-/F43	4.3V
NJU770*F4-/F15	1.5V	NJU770*F4-/F24	2.4V	NJU770*F4-/F33	3.3V	NJU770*F4-/F44	4.4V
NJU770*F4-/F16	1.6V	NJU770*F4-/F25	2.5V	NJU770*F4-/F34	3.4V	NJU770*F4-/F45	4.5V
NJU770*F4-/F17	1.7V	NJU770*F4-/F26	2.6V	NJU770*F4-/F35	3.5V	NJU770*F4-/F47	4.7V
NJU770*F4-/F18	1.8V	NJU770*F4-/F27	2.7V	NJU770*F4-/F36	3.6V	NJU770*F4-/F05	5.0V
NJU770*F4-/F19	1.9V	NJU770*F4-/F28	2.8V	NJU770*F4-/F38	3.8V	NJU770*F4-/F52	5.2V
NJU770*F4-/F02	2.0V	NJU770*F4-/F29	2.9V	NJU770*F4-/F39	3.9V	NJU770*F4-/F55	5.5V
NJU770*F4-/F21	2.1V	NJU770*F4-/F03	3.0V	NJU770*F4-/F04	4.0V	NJU770*F4-/F06	6.0V
NJU770*F4-/F22	2.2V	NJU770*F4-/F31	3.1V	NJU770*F4-/F42	4.2V		

## NJU7700

### ABSOLUTE MAXIMUM RATINGS (Ta=25°C)

PARAMETER	SYMBOL	RATINGS		UNIT
Input Voltage	V <sub>DD</sub>	+10		V
Output Voltage	V <sub>OUT</sub>	V <sub>SS</sub> -0.3~+10		V
Output Current	I <sub>OUT</sub>	50		mA
Power Dissipation	P <sub>D</sub>	F : SOT-23-5	200(*1)	mW
		F4 : SC-82AB	250(*2)	
Operating Temperature	T <sub>opr</sub>	-40 ~ +85		°C
Storage Temperature	T <sub>stg</sub>	-40 ~ +125		°C

(\*1) : Device itself

(\*2) : Mounted on glass epoxy board based on EIA/JEDEC. (114.3x76.2x1.6mm: 2Layers)

### ELECTRICAL CHARACTERISTICS (Ta=25°C)

PARAMETER	SYMBOL	TEST CONDITION	MIN.	TYP.	MAX.	UNIT	
Detection Voltage	V <sub>DET</sub>		-1.0%	-	+1.0%	V	
Hysteresis Voltage	V <sub>HYS</sub>		V <sub>DET</sub> ×0.03	V <sub>DET</sub> ×0.05	V <sub>DET</sub> ×0.08	V	
Quiescent Current	I <sub>SS</sub>	V <sub>DD</sub> =V <sub>DET</sub> +1V	V <sub>DET</sub> =1.3V~1.7V Version	-	0.5	1.0	μA
			V <sub>DET</sub> =1.8V~6.0V Version	-	0.8	1.6	μA
Output Current	I <sub>OUT</sub>	Nch, V <sub>DS</sub> =0.5V	V <sub>DD</sub> =1.2V	0.75	2.0	-	mA
			V <sub>DD</sub> =2.4V (≥2.7V Version)	4.5	7.0	-	mA
Output Leak Current	I <sub>LEAK</sub>	V <sub>DD</sub> =V <sub>OUT</sub> =9V	-	-	0.1	μA	
Detection Voltage Temperature Coefficient	Δ V <sub>DET</sub> / Δ Ta	Ta=0 ~ +85°C	-	±100	-	ppm/°C	
Operating Voltage(*3)	V <sub>DD</sub>	R <sub>L</sub> =100kΩ	0.8	-	9	V	

(\*3): The minimum Operating Voltage(V<sub>OPL</sub>) indicates the same value of the input voltage(V<sub>DD</sub>) on condition that V<sub>OUT</sub> becomes 10% or less of the input voltage(V<sub>DD</sub>).

## ■ TEST CIRCUIT

### ① COMMON TEST CIRCUIT

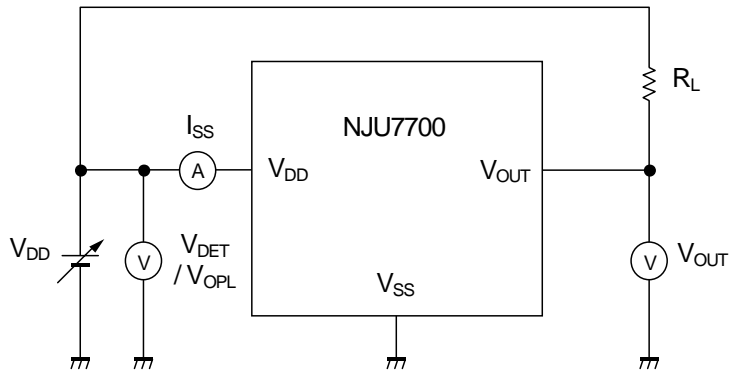

### ② OUTPUT CURRENT/OUTPUT LEAK CURRENT TEST CIRCUIT

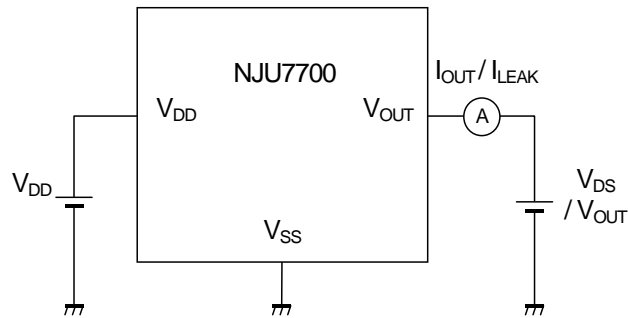

## ■ TYPICAL APPLICATION

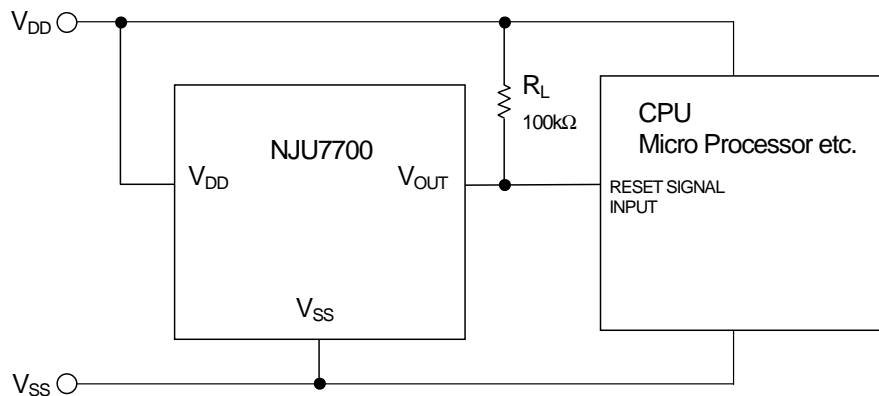

# NJU7700/01

## ■ NJU7701

### ■ ABSOLUTE MAXIMUM RATINGS (Ta=25°C)

PARAMETER	SYMBOL	RATINGS	UNIT
Input Voltage	V <sub>DD</sub>	+10	V
Output Voltage	V <sub>OUT</sub>	V <sub>SS</sub> -0.3 ~ V <sub>DD</sub> +0.3	V
Output Current	I <sub>OUT</sub>	50	mA
Power Dissipation	P <sub>D</sub>	F : SOT-23-5	200(*4)
		F4 : SC-82AB	250(*5)
Operating Temperature	Topr	-40 ~ +85	°C
Storage Temperature	Tstg	-40 ~ +125	°C

(\*4) : Device itself

(\*5) : Mounted on glass epoxy board based on EIA/JEDEC. (114.3x76.2x1.6mm: 2Layers)

### ■ ELECTRICAL CHARACTERISTICS (Ta=25°C)

PARAMETER	SYMBOL	TEST CONDITION	MIN.	TYP.	MAX.	UNIT	
Detection Voltage	V <sub>DET</sub>		-1.0%	–	+1.0%	V	
Hysteresis Voltage	V <sub>HYS</sub>		V <sub>DET</sub> ×0.03	V <sub>DET</sub> ×0.05	V <sub>DET</sub> ×0.08	V	
Quiescent Current	I <sub>SS</sub>	V <sub>DD</sub> =V <sub>DET</sub> +1V	V <sub>DET</sub> =1.3V~1.7V Version	–	0.5	1.0	μA
			V <sub>DET</sub> =1.8V~6.0V Version	–	0.8	1.6	μA
Output Current	I <sub>OUT</sub>	Nch, V <sub>DS</sub> =0.5V	V <sub>DD</sub> =1.2V	0.75	2.0	–	mA
			V <sub>DD</sub> =2.4V (≥2.7V Version)	4.5	7.0	–	mA
		Pch, V <sub>DS</sub> =0.5V	V <sub>DD</sub> =4.8V (≤3.9V Version)	2.0	3.5	–	mA
			V <sub>DD</sub> =6.0V (4.0V~5.6V Version)	2.5	4.0	–	mA
		V <sub>DD</sub> =8.4V (≥5.7V Version)	3.0	5.0	–	mA	
Detection Voltage Temperature Coefficient	Δ V <sub>DET</sub> / ΔTa	Ta=0 ~ +85°C	–	±100	–	ppm/°C	
Operating Voltage(*6)	V <sub>DD</sub>	R <sub>L</sub> =100kΩ	0.8	–	9	V	

(\*6): The minimum Operating Voltage(V<sub>OPL</sub>) indicates the same value of the input voltage(V<sub>DD</sub>) on condition that V<sub>OUT</sub> becomes 10% or less of the input voltage(V<sub>DD</sub>).

## ■ TEST CIRCUIT

### ① COMMON TEST CIRCUIT

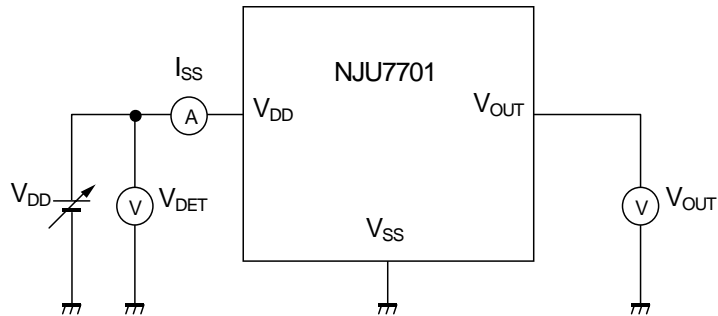

### ② Nch OUTPUT CURRENT TEST CIRCUIT

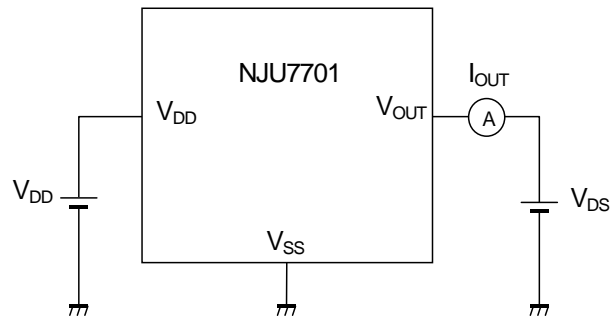

### ③ Pch OUTPUT CURRENT TEST CIRCUIT

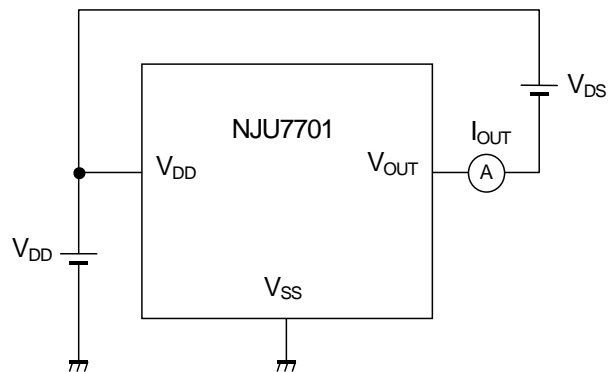

## ④ MINIMUM OPERATING VOLTAGE TEST CIRCUIT

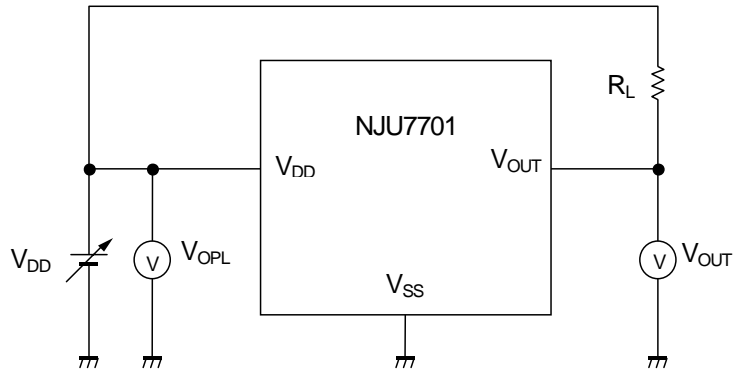

## ■ TYPICAL APPLICATION

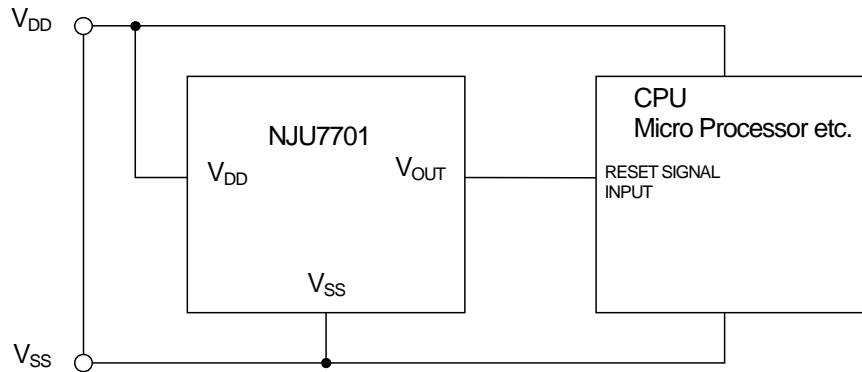

## FUNCTIONAL DESCRIPTION

### (1) Basic operation

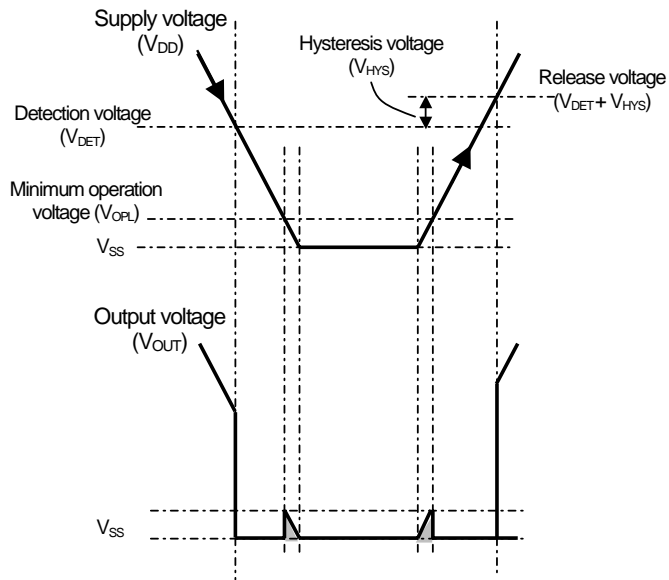

(1) When supply voltage ( $V_{DD}$ ) drops below detection voltage ( $V_{DET}$ ), Output voltage ( $V_{OUT}$ ) changes "H" to "L" to alert reset state.

(2) The reset state is kept while  $V_{DD}$  is lower than release voltage. The release voltage is a sum of  $V_{DET}$  and Hysteresis voltage ( $V_{HYS}$ ). Please refer to the (\*7) below.

(3) When  $V_{DD}$  becomes higher than the release voltage, then  $V_{OUT}$  changes from "L" to "H" to resume normal state.

(\*7)  $V_{HYS}$  is to avoid unstable  $V_{OUT}$  state caused by rapid voltage change at nearby  $V_{DET}$ .

(\*8): C-MOS output product (NJU7701) : When  $V_{DD}$  less than  $V_{OPL}$ ,  $V_{OUT}$  is free of the shaded region.

**[CAUTION]**

The specifications on this databook are only given for information, without any guarantee as regards either mistakes or omissions. The application circuits in this databook are described only to show representative usages of the product and not intended for the guarantee or permission of any right including the industrial rights.