



# PRODUCT SPECIFICATION

**Model No : CSHV-NL60xWG4-A6**

Descriptions:	
• LED Type	: High Power VEGA
• LED Package	: Lambertian
• Emitting Color	: SW / WW
• Viewing Angle	: 120°
• Encapsulating	: Silicone LENS



CUSTOMER APPROVED SIGNATURES	APPROVED BY	CHECKED BY	PREPARED BY
	 李 CSC 榮泰	 張 CSC 坤政	 馬 CSC 仁倫

**CHINA SEMICONDUCTOR CORPORATION**  
Address : 2FL. NO.909,Chung-Cheng Road,  
Chung-Ho City Taipei Hsien,Taiwan.

**OPTO PLUS TECHNOLOGIES CO.,LTD**  
Address : 696 Shun jiang Rd.,Ji Shan St.Shaoxing,  
ZheJiang,China

Tel : 886-2-2223-9696

Tel : 86-0575-88623888

Fax : 886-2-2223-9377

Fax : 86-0575-88623112

<http://www.csctw.com.tw>



<b>Spec. No.</b>	PS-0905-002
<b>Rev.</b>	A

■ **Features –**

1. High Luminous Output
2. Silicone Encapsulation
3. RoHs Compliant
4. Compatible Lead-Free Reflow Solder
5. ESD>8KV(HBM)
6. Standard Collimator Compatible
7. Low thermal resistance (junction to Case) : 10 °C/W

■ **Device Selection Guide –**

Part No.	Chip		LED Lens
	Material	Emitted Color	
CSHV-NL60SWG4-A6	InGaN/Sapphire	Standard White	Water Transparent
CSHV-NL60WWG4-A6		Warm White	

■ **Absolute Maximum Rating –**

(Ta=25°C)

Parameter	Symbol	Rating	Unit
Power Dissipation	<b>Pd</b>	2	W
Forward Current (DC)	<b>IF</b>	500	mA
Peak Forward Current *	<b>IFP</b>	700	mA
Reverse Voltage	<b>VR</b>	5	V
Operating Temp.	<b>Topr</b>	-40 ~ +85	°C
Storage Temp.	<b>Tstg</b>	-40 ~ +100	°C

\* Pulse width  $\leq 0.1$  msec. duty  $\leq 1/10$

Spec. No.	PS-0905-002
Rev.	A

■ Package Outline Dimensions –

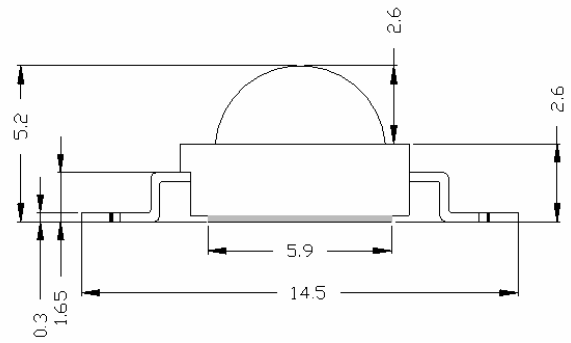
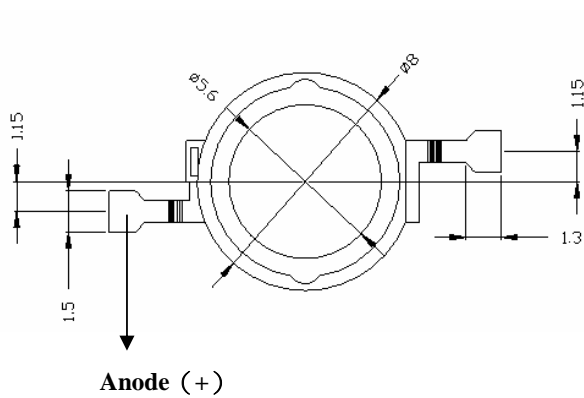
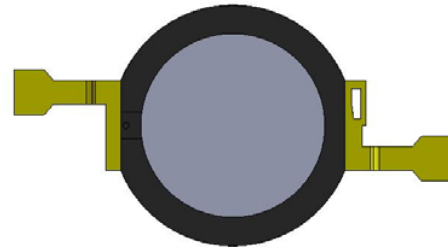
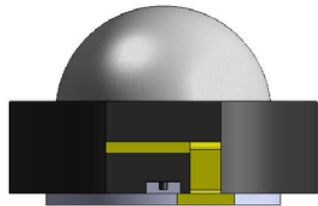
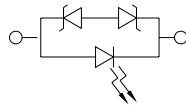
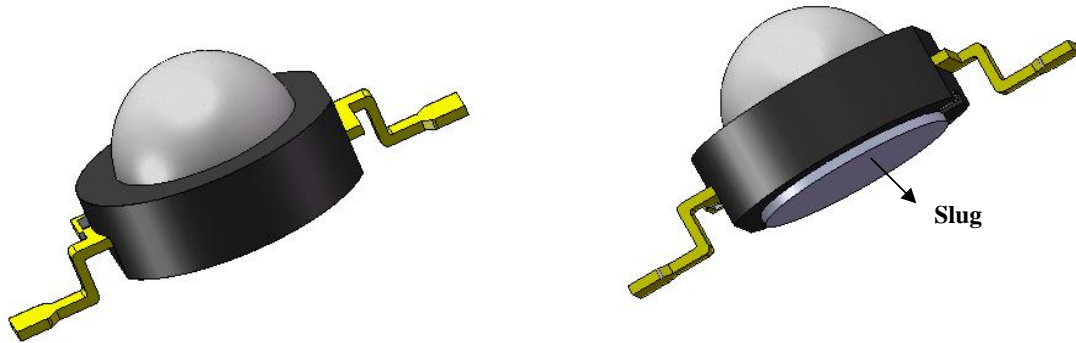

Notes: Tolerance of measurement of Dimension:  $\pm 0.25\text{mm}$



<b>Spec. No.</b>	PS-0905-002
<b>Rev.</b>	A

■ **Electrical / Optical Characteristics –**

(Ta=25°C)

Parameter	Symbol	Min.	Typ.	Max.	Unit	Condition
Forward Voltage	VF		3.4	4	V	IF=350mA
Luminous Flux	Φv	58	75		lm	
Viewing Angle	2θ 1/2		120		deg	
Reverse Current	IR			50	μA	VR=5V

■ **Luminous Flux Rank Limits ( IF = 350mA )**

unit : lm

Luminous Flux Part No.	58-70	70-80	80-90	90-100
	CSHV-NL60SWG4-A6	K	L	M
CSHV-NL60WWG4-A6	K	L	M	N

■ **Color Rank Limits ( IF = 350mA )**

**CSHV-NL60SWG4-A6**

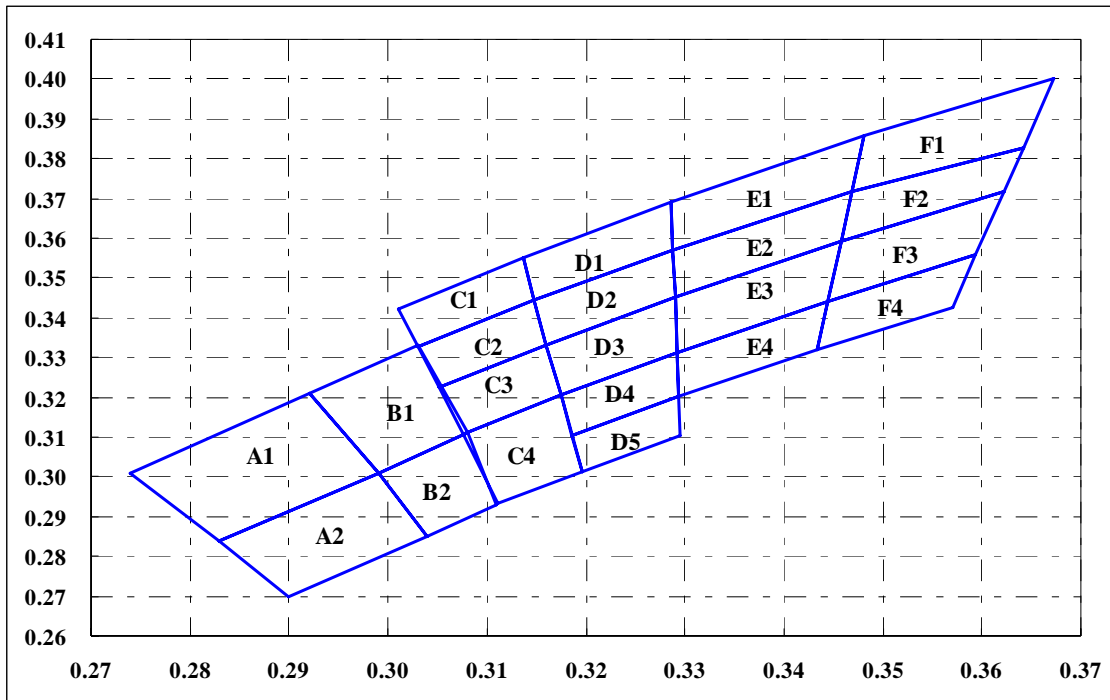

<b>Rank A Color Temperature:8000~10000K</b>									
<b>A1</b>					<b>A2</b>				
<b>X</b>	0.2920	0.2740	0.2830	0.2990	<b>X</b>	0.3040	0.2900	0.2830	0.2990
<b>Y</b>	0.3210	0.3010	0.2840	0.3010	<b>Y</b>	0.2850	0.2700	0.2840	0.3010

<b>Rank B Color Temperature:6700~8000K</b>									
<b>B1</b>					<b>B2</b>				
<b>X</b>	0.2990	0.2920	0.3030	0.3080	<b>X</b>	0.3040	0.2990	0.3080	0.3110
<b>Y</b>	0.3010	0.3210	0.3330	0.3110	<b>Y</b>	0.2850	0.3010	0.3110	0.2930

<b>Rank C Color Temperature:6000~6700K</b>									
<b>C1</b>					<b>C3</b>				
<b>X</b>	0.3011	0.3136	0.3148	0.3031	<b>X</b>	0.3052	0.3160	0.3175	0.3076
<b>Y</b>	0.3422	0.3550	0.3444	0.3327	<b>Y</b>	0.3224	0.3332	0.3204	0.3108
<b>C2</b>					<b>C4</b>				
<b>X</b>	0.3031	0.3148	0.3160	0.3052	<b>X</b>	0.3076	0.3175	0.3196	0.3112
<b>Y</b>	0.3327	0.3444	0.3332	0.3224	<b>Y</b>	0.3108	0.3204	0.3013	0.2932



<b>Spec. No.</b>	PS-0905-002
<b>Rev.</b>	A

<b>Rank D Color Temperature:5300~6000K</b>									
<b>D1</b>					<b>D4</b>				
<b>X</b>	0.3136	0.3286	0.3288	0.3148	<b>X</b>	0.3175	0.3292	0.3294	0.3186
<b>Y</b>	0.3550	0.3690	0.3569	0.3444	<b>Y</b>	0.3204	0.3313	0.3202	0.3102
<b>D2</b>					<b>D5</b>				
<b>X</b>	0.3148	0.3288	0.3290	0.3160	<b>X</b>	0.3186	0.3294	0.3295	0.3196
<b>Y</b>	0.3444	0.3569	0.3451	0.3332	<b>Y</b>	0.3102	0.3202	0.3105	0.3013
<b>D3</b>									
<b>X</b>	0.3160	0.3290	0.3292	0.3175					
<b>Y</b>	0.3332	0.3451	0.3313	0.3204					

<b>Rank E Color Temperature:4750~5300K</b>									
<b>E1</b>					<b>E3</b>				
<b>X</b>	0.3286	0.3481	0.3469	0.3288	<b>X</b>	0.3290	0.3458	0.3444	0.3292
<b>Y</b>	0.3690	0.3856	0.3717	0.3569	<b>Y</b>	0.3451	0.3592	0.3442	0.3313
<b>E2</b>					<b>E4</b>				
<b>X</b>	0.3288	0.3469	0.3458	0.3290	<b>X</b>	0.3292	0.3444	0.3434	0.3294
<b>Y</b>	0.3569	0.3717	0.3592	0.3451	<b>Y</b>	0.3313	0.3442	0.3320	0.3202

<b>Rank F Color Temperature:4300~4750K</b>									
<b>F1</b>					<b>F3</b>				
<b>X</b>	0.3481	0.3673	0.3642	0.3469	<b>X</b>	0.3458	0.3622	0.3594	0.3444
<b>Y</b>	0.3856	0.4003	0.3829	0.3717	<b>Y</b>	0.3592	0.3716	0.3557	0.3442
<b>F2</b>					<b>F4</b>				
<b>X</b>	0.3469	0.3642	0.3622	0.3458	<b>X</b>	0.3444	0.3594	0.3571	0.3434
<b>Y</b>	0.3717	0.3829	0.3716	0.3592	<b>Y</b>	0.3442	0.3557	0.3426	0.3320

**CSHV-NL60WWG4-A6**

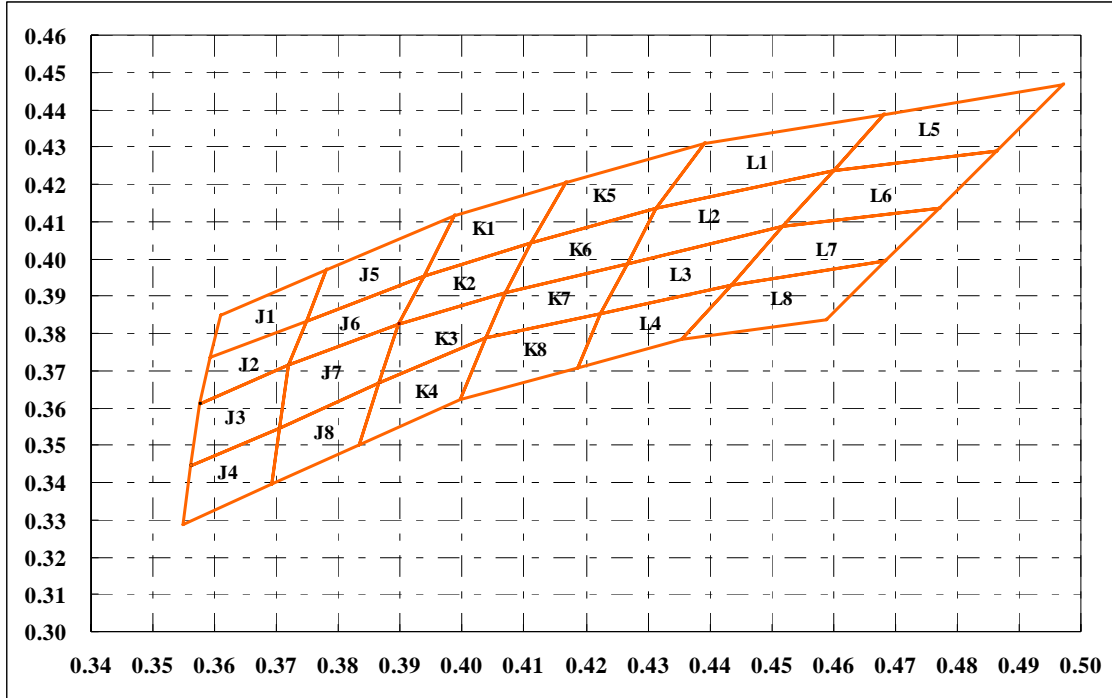

<b>Rank J Color Temperature:3800~4600K</b>									
<b>J1</b>					<b>J5</b>				
<b>X</b>	0.3593	0.3610	0.3780	0.3748	<b>X</b>	0.3748	0.3780	0.3988	0.3938
<b>Y</b>	0.3736	0.3850	0.3970	0.3834	<b>Y</b>	0.3834	0.3970	0.4116	0.3954
<b>J2</b>					<b>J6</b>				
<b>X</b>	0.3575	0.3593	0.3748	0.3720	<b>X</b>	0.3720	0.3748	0.3938	0.3897
<b>Y</b>	0.3612	0.3736	0.3834	0.3714	<b>Y</b>	0.3714	0.3834	0.3954	0.3823
<b>J3</b>					<b>J7</b>				
<b>X</b>	0.3561	0.3575	0.3720	0.3705	<b>X</b>	0.3705	0.3720	0.3897	0.3866
<b>Y</b>	0.3445	0.3612	0.3714	0.3544	<b>Y</b>	0.3544	0.3714	0.3823	0.3666
<b>J4</b>					<b>J8</b>				
<b>X</b>	0.3548	0.3561	0.3705	0.3692	<b>X</b>	0.3692	0.3705	0.3866	0.3834
<b>Y</b>	0.3285	0.3445	0.3544	0.3394	<b>Y</b>	0.3394	0.3544	0.3666	0.3501

<b>Rank K Color Temperature:3175~3800K</b>									
<b>K1</b>					<b>K5</b>				
<b>X</b>	0.3938	0.3988	0.4167	0.4112	<b>X</b>	0.4112	0.4167	0.4390	0.4314
<b>Y</b>	0.3954	0.4116	0.4203	0.4043	<b>Y</b>	0.4043	0.4203	0.4310	0.4135
<b>K2</b>					<b>K6</b>				
<b>X</b>	0.3897	0.3938	0.4112	0.4069	<b>X</b>	0.4069	0.4112	0.4314	0.4267
<b>Y</b>	0.3823	0.3954	0.4043	0.3908	<b>Y</b>	0.3908	0.4043	0.4135	0.3986
<b>K3</b>					<b>K7</b>				
<b>X</b>	0.3866	0.3897	0.4069	0.4037	<b>X</b>	0.4037	0.4069	0.4267	0.4222
<b>Y</b>	0.3666	0.3823	0.3908	0.3786	<b>Y</b>	0.3786	0.3908	0.3986	0.3853
<b>K4</b>					<b>K8</b>				
<b>X</b>	0.3834	0.3866	0.4037	0.3996	<b>X</b>	0.3996	0.4037	0.4222	0.4186
<b>Y</b>	0.3501	0.3666	0.3786	0.3624	<b>Y</b>	0.3624	0.3786	0.3853	0.3709

<b>Rank L Color Temperature:2500~3175K</b>									
<b>L1</b>					<b>L5</b>				
<b>X</b>	0.4314	0.4390	0.4680	0.4601	<b>X</b>	0.4601	0.4680	0.4970	0.4863
<b>Y</b>	0.4135	0.4310	0.4385	0.4238	<b>Y</b>	0.4238	0.4385	0.4466	0.4290
<b>L2</b>					<b>L6</b>				
<b>X</b>	0.4267	0.4314	0.4601	0.4519	<b>X</b>	0.4519	0.4601	0.4863	0.4770
<b>Y</b>	0.3986	0.4135	0.4238	0.4086	<b>Y</b>	0.4086	0.4238	0.4290	0.4137
<b>L3</b>					<b>L7</b>				
<b>X</b>	0.4222	0.4267	0.4519	0.4434	<b>X</b>	0.4434	0.4519	0.4770	0.4683
<b>Y</b>	0.3853	0.3986	0.4086	0.3930	<b>Y</b>	0.3930	0.4086	0.4137	0.3995
<b>L4</b>					<b>L8</b>				
<b>X</b>	0.4186	0.4222	0.4434	0.4355	<b>X</b>	0.4355	0.4434	0.4683	0.4588
<b>Y</b>	0.3709	0.3853	0.3930	0.3785	<b>Y</b>	0.3785	0.3930	0.3995	0.3838

**Notes :**

1. Tolerance of measurement of luminous Flux :  $\pm 10\%$
2. Tolerance of measurement of Color Coordinates :  $\pm 0.01$
3. All data are measured by CSC's test equipment.
4. Please confirm with CSC sales , if your request different from standard specification.



■ **Typical Electrical / Optical Characteristics Curves –**  
( $T_a = 25^\circ\text{C}$  Unless Otherwise Noted)

**Figure 1. Relative Luminous FLux vs. Forward Current**

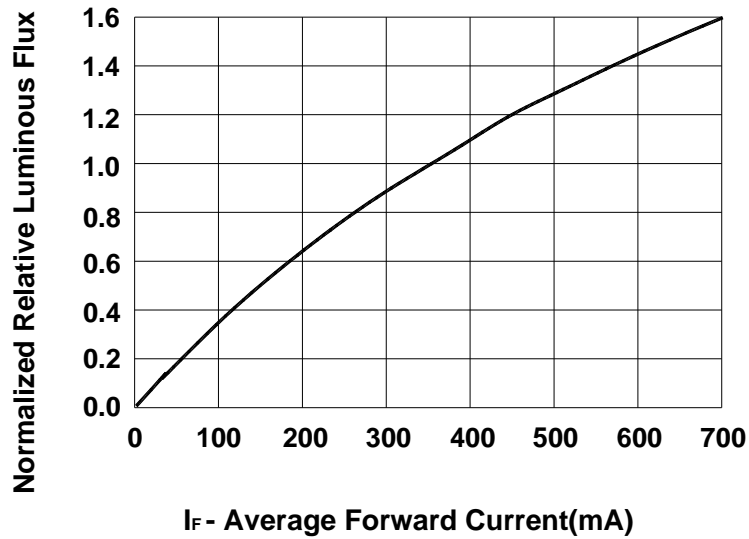

**Figure 2. Forward Current vs. Forward Voltage**

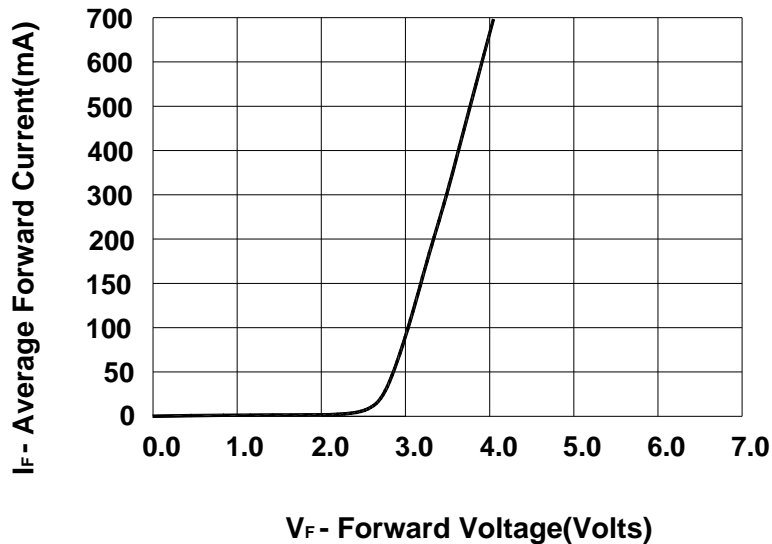



Spec. No.	PS-0905-002
Rev.	A

Figure 3. Maximum Forward Current  
vs. Ambient Temperature.  
Derating based on  $T_{JMAX}=120^{\circ}C$

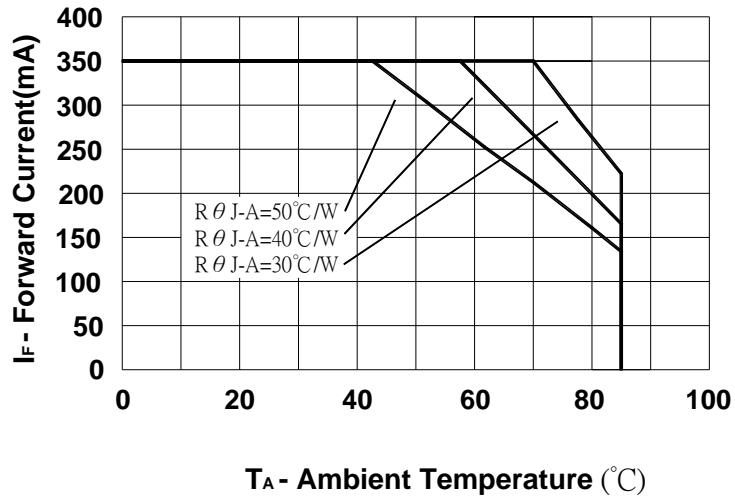
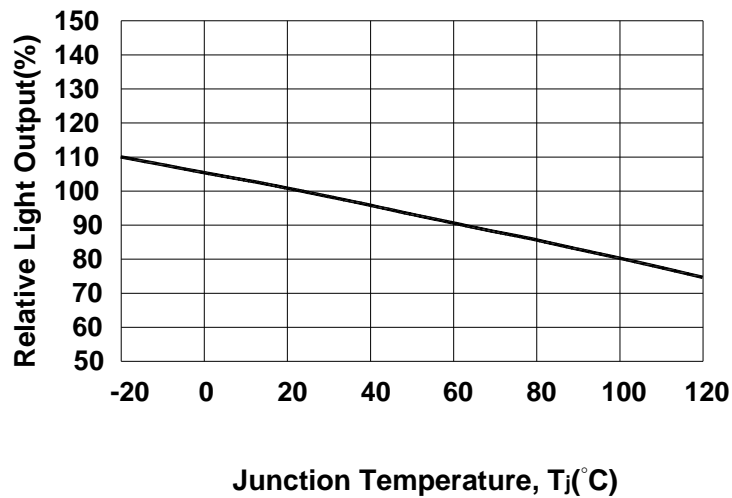
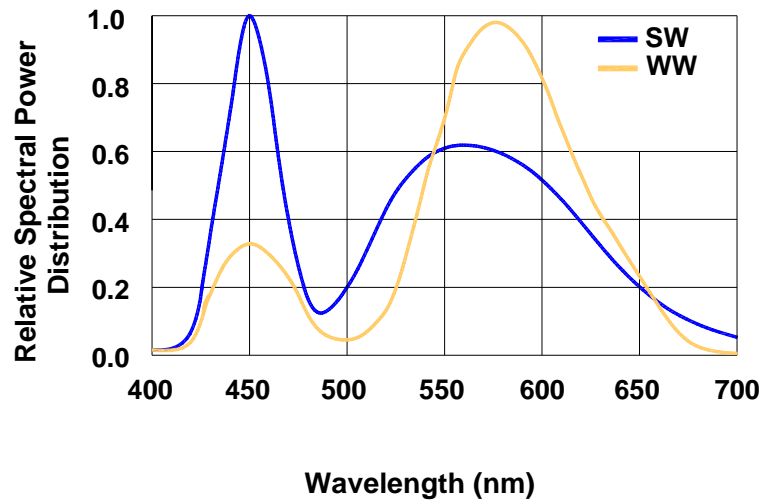

Figure 4. Relative Light Output  
vs. Junction Temperature



**Figure 5. Relative Spectral Power Distribution vs. Wavelength**



**Figure 6. Relative Luminosity vs. Radiation Angle**

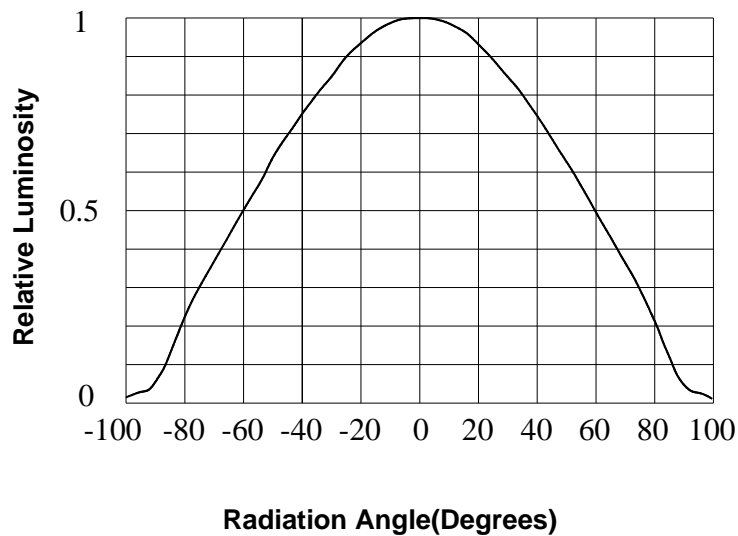

## ■ Reflow Soldering Characteristics –

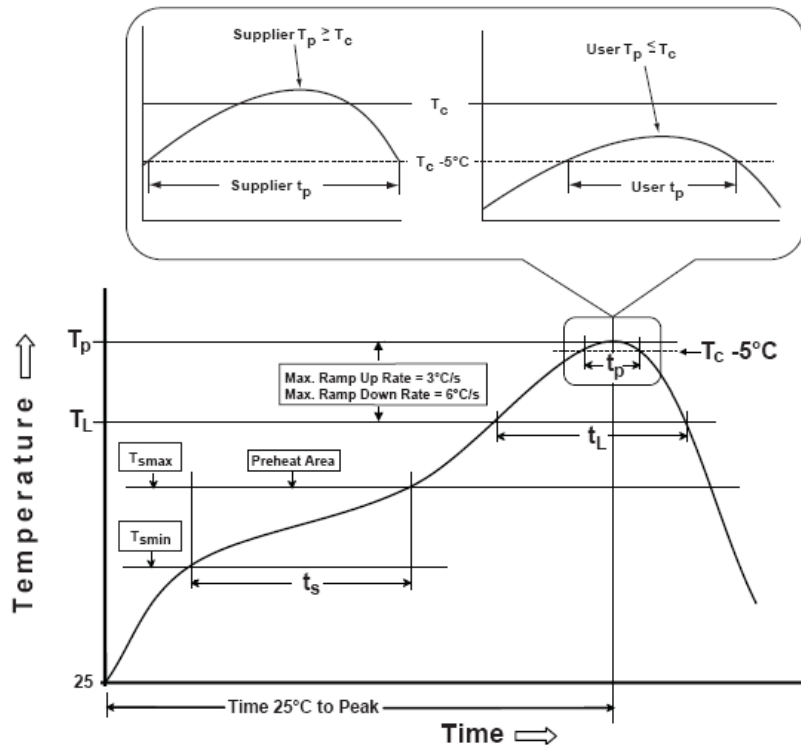

Profile Feature	Sn-Pb Eutectic Assembly	Pb-Free Assembly
<b>Preheat &amp; Soak</b>		
Temperature Min ( $T_{smin}$ )	100°C	150°C
Temperature Max ( $T_{smax}$ )	150°C	200°C
Time ( $t_s$ ) from ( $T_{smin}$ to $T_{smax}$ )	60-120 seconds	60-120 seconds
Ramp-up rate ( $T_L$ to $T_p$ )	3°C/second max.	3°C/second max.
Liquidous temperature ( $T_L$ )	183°C	217°C
Time ( $t_L$ ) maintained above $T_L$	60-150 seconds	60-150 seconds
Peak package body temperature ( $T_p$ )	For users $T_p$ must not exceed the Classification temp in Table 4-1. For suppliers $T_p$ must equal or exceed the Classification temp in Table 4-1.	For users $T_p$ must not exceed the Classification temp in Table 4-2. For suppliers $T_p$ must equal or exceed the Classification temp in Table 4-2.
Time ( $t_p$ )* within 5°C of the specified classification temperature ( $T_c$ ), see Figure 5-1.	20* seconds	30* seconds
Ramp-down rate ( $T_p$ to $T_L$ )	6°C/second max.	6°C/second max.
Time 25°C to peak temperature	6 minutes max.	8 minutes max.
*Tolerance for peak profile temperature ( $T_p$ ) is defined as a supplier minimum and a user maximum		

## ■ Hand Soldering Characteristics –

<b>Soldering temperature</b>	<b>260°C</b>
<b>Soldering time</b>	<b>5 sec</b>

**Notes : All temperatures refer to solder Pad**

<b>Spec. No.</b>	PS-0905-002
<b>Rev.</b>	A

■ **Package –**

**1. Tube : 50pcs/tube**

CSC P/N : CSC Production number  
 Flux : Intensity grade  
 Color : Color grade  
 Q'ty : Quantity

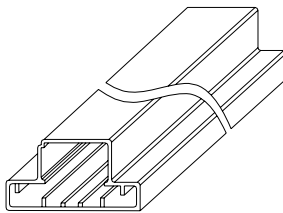



Part No :
Flux : Color: VF: Q'ty: pcs

**on tube**

**2. Anti-electrostatic bag : 10 tubes/bag**

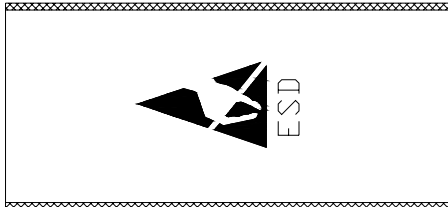
Product type : Vega Power  
 CSC P/N : CSC Production number  
 Flux : Intensity grade  
 Color : Color grade  
 Lot No : Lot Number  
 Date code : Production time  
 Q'ty : Quantity





Product Type :	Part No :
Flux : Color: VF: Q'ty: PCS	RoHS
Lot No : Date code :	QC :
	

**on anti-electrostatic bag**

**3. Carton: 2 anti-electrostatic bags/carton**

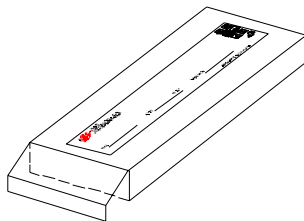
CSC P/N : CSC Production number  
 Q'ty : Quantity  
 Date code : Production time



 <p>CSC OPTOELECTRONICS A DIVISION OF CHINA SEMICONDUCTOR CORP</p>		
	P / N _____ Q'TY _____ PCS _____	Data code _____
SIZE:49.5X9.5X4.5cm		

**on carton**

■ **Precautions for use –**

1 . Please use LEDES refer to JEDEC 2a(Industry Best Moisture Sensitivity Level) as below

Floor life		Standard		Accelerated Environment	
time	conditions	time	conditions	time	conditions
4	≤ 30°C/60%RH	(hours)	30°C/60%RH	(hours)	60°C/60%RH
weeks		696 <sup>2</sup> +5/-0		120+1/-0	

**Notes : The standard soak time includes a default value of 24 hours for semiconductor exposure time between bake and bag and includes the maximum time allowed out of bag at the distributor's facility.**

- 2 . Please confirm the moisture card in the anti-electrostatic bag after opening package.  
If it shows 50%RH, LEDs should be performed baking treatment before used.  
( bake condition: At 125°C +5/-0 for 24 hours )
- 3 . Any mechanical force or any excess vibration on LENS should be avoid during operating.
- 4 . LED should be stored below 60%RH after opening package.
- 5 . Please refer to Fig.3 of Page 10 to choose current drive to use. Ambient temperature will affect current.

**Notes : The specifications are subject to change without notice. Please contact us for updated information.**