

Compact Two-way Detection Type Detector Switch

SSCM Series

Compact, low-profile, and high-reliability type provides detection in the right and left directions.

- Power
- Push
- Slide
- Rotary
- Encoders
- Detector**
- Dual-in-line Package Type
- Multi Control Devices
- TACT
- Custom-Products

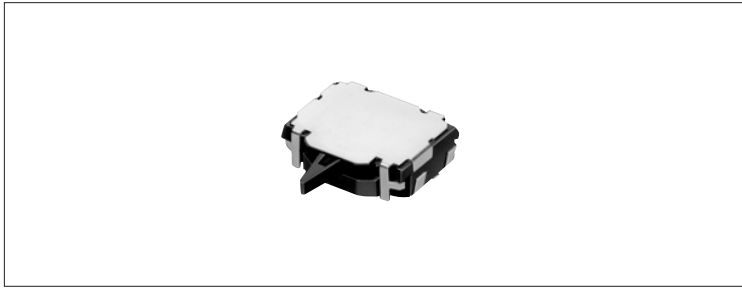

Car Use

Features

- Two right and left directions can be detected.
- Small size and thin type of 5mm in width, 4mm in length, and 1.5mm in height.
- Reflow soldering type.
- Double-sided sliding contact provides high reliability.

Applications

- For detection mechanism devices, including DVD players, DSCs, and car audio systems
- For switching modes and zoom operation of DVD players and DSCs and digital camcorders

Typical Specifications

Items		Specifications
Rating (max.) (Resistive load)		1mA 5V DC
Contact resistance (Initial performance/After lifetime)		2Ω max./5Ω max.
Operating force		0.35N max.
Operating life	Without load	50,000 cycles
	With load	50,000 cycles (1mA 5V DC)

Products Line

Poles	Positions	Total travel (mm)	Terminal style	Locating lug	Minimum packing unit (pcs.)	Products No.
1	2	1.57	For PC board (Reflow)	With	3,000	SSCM110100
				Without		SSCM120100

For other detailed specifications, see P.303
For specifications for the taping package, see P.307

Dimensions

Unit:mm

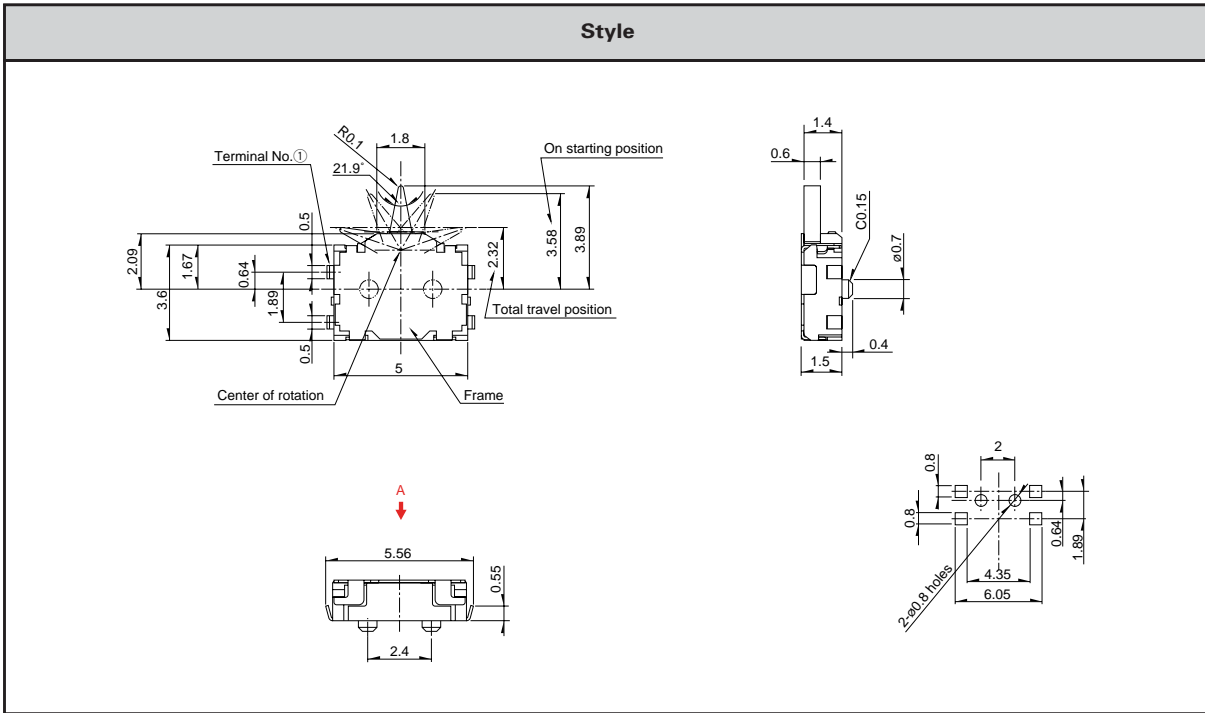

Power

Push

Slide

Rotary

Encoders

Detector

Dual-in-line
Package Type

Multi Control
Devices

TACT

Custom-
Products

Terminal Layout (Viewed from Direction A)

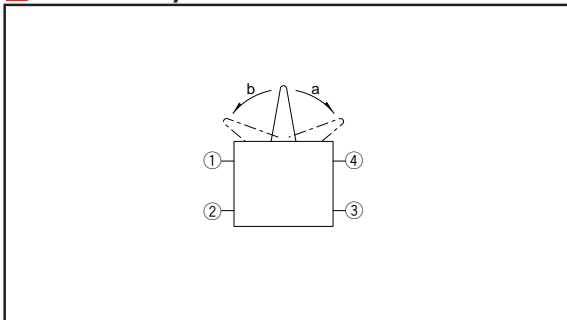

Circuit Diagram

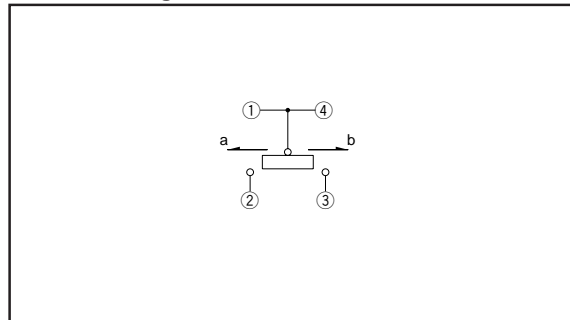

Note

Only the configurations with the location lug are indicated in the dimensions.

Products Specifications

Items		Series											
		SPPB	SPVE	SPPW8	SPVM	SPVR	SPVP	SPVN	SPVG	SPVL	SSCM		
Operating temperature range		-10°C to +60°C											
Rating (max.) (Resistive load)		0.1A 30V DC	0.1A 12V DC	0.1A 30V DC	1mA 5V DC				50mA 20V DC	1mA 5V DC			
Electrical performance	Initial contact resistance	1 Ω max.	500mΩ max.	1 Ω max.	2 Ω max.	3 Ω max.	5 Ω max.	2 Ω max.	500mΩ max.	2 Ω max.			
	Insulation resistance	100MΩ min. 100V DC											
	Voltage proof	100V AC for 1 min.											
Mechanical performance	Robustness of terminal	3N for 1 min.	0.5N for 1 min.	3N for 1 min.	1N for 1 min.	0.5N for 1 min.			1N for 1 min.	0.5N for 1 min.			
	Robustness of actuator	10N	5N	10N	5N	2N	5N	10N	5N	0.5N			
	Vibration	10 to 55 to 10Hz/min., the amplitude is 1.5mm for all the frequencies, in the 3 direction of X, Y and Z for 2 hours respectively											
	Resistance to soldering heat	Manual soldering	300±5°C, 5s max.	350±5°C, 3s max.									
		Dip soldering	260±5°C, 5±1s	—	255±5°C, 5±1s	—							
Reflow soldering		Please see P.306											
Durability	Operating life without load	50,000 cycles 2Ω max.	50,000 cycles 1Ω max.	100,000 cycles 2Ω max.	50,000 cycles 5Ω max.		50,000 cycles 10Ω max.	50,000 cycles 5Ω max.	100,000 cycles 1Ω max.	50,000 cycles 5Ω max.			
	Operating life with load	(0.1A 30V DC) 50,000 cycles 2Ω max.	(0.1A 12V DC) 50,000 cycles 1Ω max.	(0.1A 30V DC) 100,000 cycles 2Ω max.	(1mA 5V DC) 50,000 cycles 5Ω max.		(1mA 5V DC) 50,000 cycles 10Ω max.	(1mA 5V DC) 50,000 cycles 5Ω max.	(50mA 20V DC) 100,000 cycles 1Ω max.	(1mA 5V DC) 50,000 cycles 5Ω max.			
Environmental performance	Cold	-20±2°C for 96h	-25±2°C for 96h	-20±2°C for 96h							-40±2°C for 96h	-20±2°C for 96h	
	Dry heat	85±2°C for 96h											
	Damp heat	40±2°C, 90 to 95%RH for 96h											

Power

Push

Slide

Rotary

Encoders

Detector

Dual-in-line
Package Type

Multi Control
Devices

TACT

Custom-
Products

Soldering Conditions

Example of Reflow Soldering Condition

1. Heating method: Double heating method with infrared heater.
2. Temperature measurement: Thermocouple 0.1 to 0.2 ϕ CA (K) or CC (T) at soldering portion (copper foil surface). A heat resisting tape should be used for fixed measurement.
3. Temperature profile

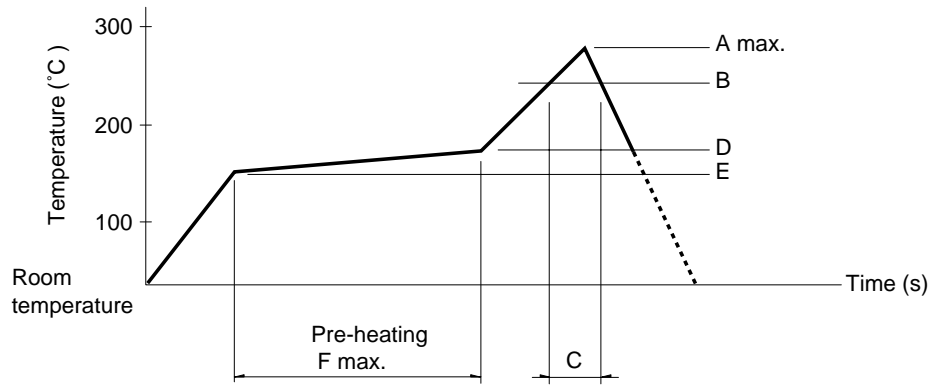

Series (Reflow type)	A (°C) 3s max.	B (°C)	C (s)	D (°C)	E (°C)	F (s)
SPPB	250	230	40	180	150	120
SPVE	260					
SPPW8	250	200	20	180	150	120
SPVM	260	230	40			
SPVR						
SPVP						
SPVN						
SPVG						
SPVL	260	230	40	180	150	120
SSCM						
SPPY5	240		20	150	Room Temperature	180

Notes

1. The condition mentioned above is the temperature on the mounting surface of a PC board. There are cases where the PC board's temperature greatly differs from that of the switch, depending on the PC board's material, size, thickness, etc. The above-stated conditions shall also apply to switch surface temperatures.
2. As the conditions vary some how depending on the kind of reflow soldering equipment, please make sure you have the right one before use.

Taping Specifications

Taping Packaging

Reel Size

Unit:mm

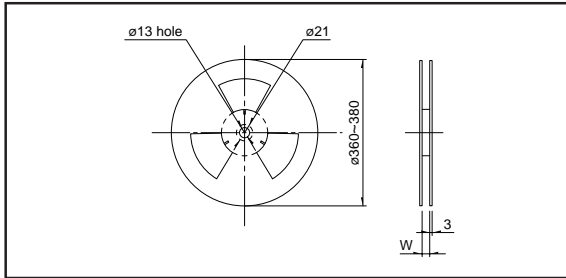

Series		Number of packages (pcs.)			Reel width W (mm)	Tape width (mm)
		1 reel	1 case / domestic	1 case / export packing		
SPPB	53 (Horizontal)	1,500	3,000	6,000	24.4	24
	53 (Vertical)	600	1,200	2,400		
	63, 64	1,300	2,600	5,200		
SPVE	Standard	h=3.8	2,800	5,600	12.4	12
		h=4.1				
		h=4.8	2,200	4,400		
		h=5.2	2,000	4,000		
		h=5.5				
	Low-profile	h=3.3	2,800	5,600		
		h=4.75	2,000	4,000		
SPPW81	h = 6.1 (Reflow)	1,000	2,000	4,000	24.4	24
	h = 6.55 (Reflow)					
	h = 7.6 (Reflow)	850	1,700	3,400		
SPVM		3,000	6,000	12,000	16.4	16
SPVR		2,500	5,000	10,000		
SPVP		4,500	9,000	18,000		
SPVN		5,000	10,000	20,000		
SPVG		2,500	5,000	10,000		
SPVL		5,000	10,000	20,000		
SSCM		3,000	6,000	12,000		
SPPY5		550	1,650	3,300		

Power

Push

Slide

Rotary

Encoders

Detector

Dual-in-line
Package Type

Multi Control
Devices

TACT

Custom-
Products

Note

Order products in N minimum packing units(1 reel or 1 case).