

VFT14C Series Micro-miniature OCXO

Product Data Sheet

Features

- Low Cost DIL 14 package
- High Vacuum Sealed Crystal
- Low Power Consumption (<500 mW)
- Fast Warm-up Time (1 minute)
- Stratum3 or better Stability
- Low Aging < 3 ppm over life
- Very Low Phase Noise (-160dBc/Hz TYP)
- HCMOS/TTL output
- 8 MHz to 160 MHz Frequencies Available
- Voltage Control Optional

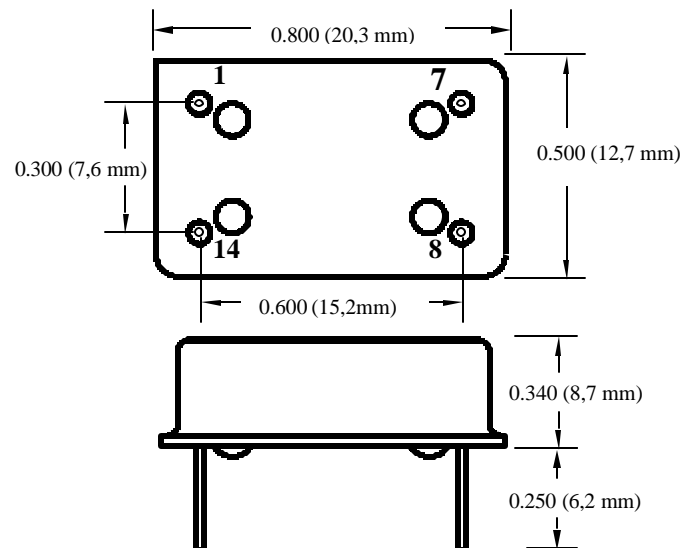

Applications

- Telecommunications
- Data Communications
- Instrumentation

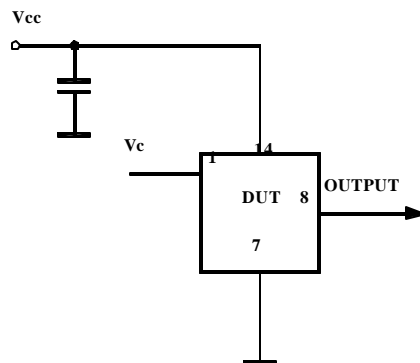

VFT14C Series

Micro-miniature OCXO

Specifications:

Parameter	Symb	Condition	Min	Typ	Max	Unit	Note
Absolute Maximum Ratings							
Input Break Down Voltage	V _{cc}		-0.5		7.0	V	
Storage temper.	T _s		-40		85	°C	
Control Voltage	V _c		-1		6	V	

Electrical

Frequency	F		8	10.000	160	MHz	
Frequency stability	ΔF/F	vs. Temp.		±100	±280	ppb	See chart below
		vs. Supply		10	50	ppb/V	
Aging		per day		5E-9			after 30 days
		first year		3E-7			
		15 years			3E-6		
Allan Variance		.1s to 100s		5E-11			
Calibration		No voltage control			± 2	ppm	
V _{cc} sensitivity				5E-8/V			
Load sensitivity		For 10% change			5E-8		
SSB Phase Noise		10 Hz		-90		dBc/Hz	
		100 Hz		-120			
		10 KHz		-160			
Retrace		After 30 minutes			±50	ppb	
G-sensitivity		worst direction			±2.0	ppb/G	
Input Voltage	V _{cc}		4.75	5.0	5.25	V	3.3V±5% optional
Input Current	I _{cc}	steady state, 25°C steady state, -30°C start-up current		100/150 180/250 500/600	120/180	mA	5V/3.3 supply
Load		10KOhm//15pF					
Warm-up time	τ	to 0.3 ppm accuracy		1	2	min	
Output Waveform		3.3V HCMOS/TTL compatible					
Control voltage	V _c		0		4.0/2.8	V	5V/3.3 supply
Pull range		from nominal F	±10			ppm	
Deviation slope		Monotonic, posit		5		ppm/V	
Setability	V _{c0}	@25°C, F _{nom} .	1.0/0.8	2.0/1.4	3.0/2.2	V	5V/3.3 supply

All parameters for 10 MHz

Environmental and Mechanical

Operating temp. range	-30°C to 70°C Standard, Other options – see chart below
Mechanical Shock	Per MIL-STD-202, 30G, 11ms
Vibration	Per MIL-STD-202, 5G to 2000 Hz
Soldering Conditions	Leads Temperature 260°C, for 10s, Max
Hermetic Seal	Leak rate less than 1x10 ⁻⁸ atm.ccm/s of helium

Electrical Connections

Pin Out	Pin 1- V _c or N/C; Pin 7- Case, GND; Pin8 – Output; Pin 14 - V _{cc}
---------	---

Creating a Part Number

VFT14C



FREQUENCY, MHz

Rev 12/05

Temperature Range

Code	Specification
A	0°C to 50°C
B	-10°C to 60°C
C	0°C to 70°C
D	-20°C to 70°C
E	-30°C to 70°C
F	-40°C to 85°C

Temperature Stability

Code	Specification
05	5x10 ⁻⁸
10	1x10 ⁻⁷
28	2.8x10 ⁻⁷
30	3x10 ⁻⁷
50	5x10 ⁻⁷
YZ	YZx10 ⁻⁸

“V” for Volt. Control

Not all combinations are available.
Consult Factory .

Supply Voltage

Code	Specification
5	5V ± 5%
3	3.3V ± 5%