

CMF02

Switching Mode Power Supply Applications
DC/DC Converter Applications

- Repetitive peak reverse voltage: $V_{RRM} = 600\text{ V}$
- Average forward current: $I_F (AV) = 1.0\text{ A}$
- Forward voltage: $V_{FM} = 2.0\text{ V (max)}$
- Very fast reverse-recovery time: $t_{rr} = 100\text{ ns (max.)}$
- Suitable for compact assembly due to small surface-mount package “M-FLAT™” (Toshiba package name)

Absolute Maximum Ratings ($T_a = 25^\circ\text{C}$)

Characteristic	Symbol	Rating	Unit
Repetitive peak reverse voltage	V_{RRM}	600	V
Average forward current	$I_F (AV)$	1.0 (Note 1)	A
Peak one-cycle surge forward current (non-repetitive)	I_{FSM}	10 (50 Hz) (Note 3)	A
Junction temperature	T_j	-40~150	°C
Storage temperature range	T_{stg}	-40~150	°C

Note 1: $T\ell = 108^\circ\text{C}$
Rectangular waveform ($\alpha = 180^\circ$)

Note 2: Using continuously under heavy loads (e.g. the application of high temperature/current/voltage and the significant change in temperature, etc.) may cause this product to decrease in the reliability significantly even if the operating conditions (i.e. operating temperature/current/voltage, etc.) are within the absolute maximum ratings. Please design the appropriate reliability upon reviewing the Toshiba Semiconductor Reliability Handbook (“Handling Precautions”/Derating Concept and Methods) and individual reliability data (i.e. reliability test report and estimated failure rate, etc).

Note 3: This rating specifies the non-repetitive peak current in one cycle of a 50 Hz sine wave, condition angle 180° . Therefore the rating applies only to abnormal operation, which seldom occurs during the lifespan of a device.

Unit: mm

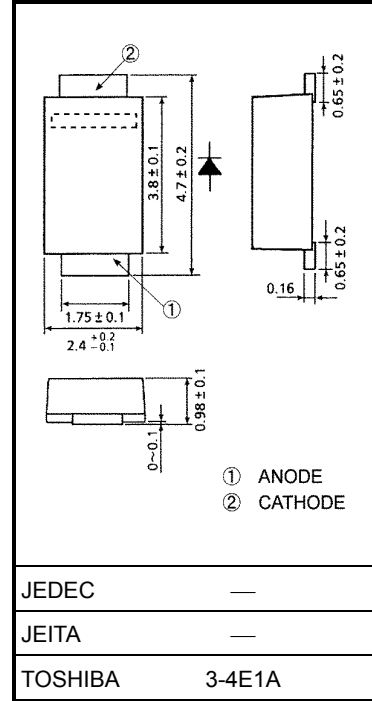

Weight: 0.023 g (typ.)

Electrical Characteristics (Ta = 25°C)

Characteristic	Symbol	Test Condition	Min	Typ.	Max	Unit
Peak forward voltage	V_{FM}	$I_{FM} = 1.0 \text{ A}$ (pulse test)	—	—	2.0	V
Repetitive peak reverse current	I_{RRM}	$V_{RRM} = 600 \text{ V}$ (pulse test)	—	—	50	μA
Reverse recovery time	t_{rr}	$I_F = 1 \text{ A}$, $di/dt = -30 \text{ A}/\mu\text{s}$	—	—	100	ns
Forward recovery time	t_{fr}	$I_F = 1 \text{ A}$	—	270	—	ns
Thermal resistance	$R_{th(j-a)}$	Device mounted on a ceramic board (board size: 50 mm × 50 mm) (soldering land: 2 mm × 2 mm) (board thickness: 0.64 t)	—	—	60	$^{\circ}\text{C}/\text{W}$
		Device mounted on a glass-epoxy board (board size: 50 mm × 50 mm) (soldering land: 6 mm × 6 mm) (board thickness: 1.6 t)	—	—	135	
		Device mounted on a glass-epoxy board (board size: 50 mm × 50 mm) (soldering land: 2.1 mm × 1.4 mm) (board thickness: 1.6 t)	—	—	210	
Thermal resistance (junction to lead)	$R_{th(j-t)}$	—	—	—	16	$^{\circ}\text{C}/\text{W}$

Marking

Abbreviation Code	Part No.
F2	CMF02

Standard Soldering Pad

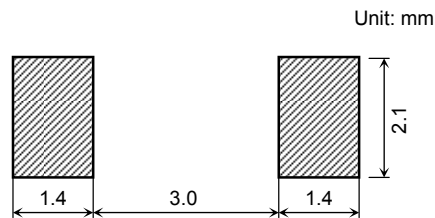

Handling Precautions

Thermal resistance between junction and ambient fluctuates depending on the mounting condition of the device. When using the device, be sure to design the circuit board and soldering land size to match the appropriate thermal resistance value.

Refer to the Rectifier databook for further information.

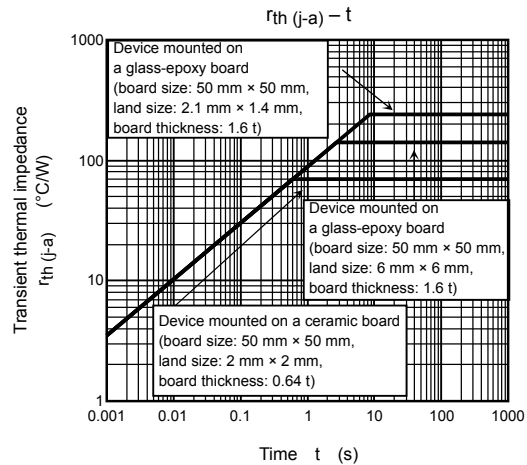
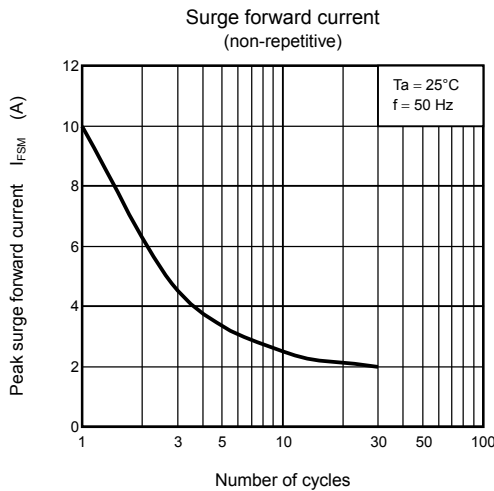
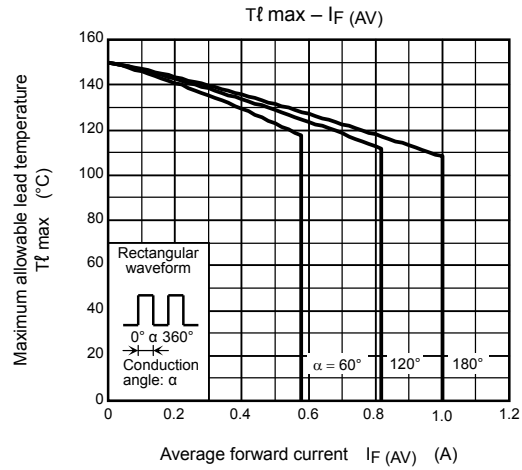
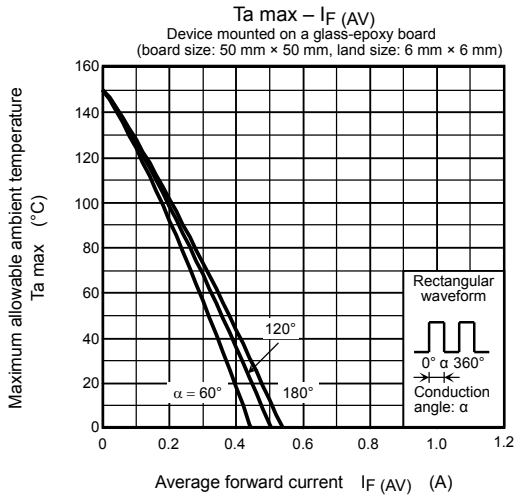
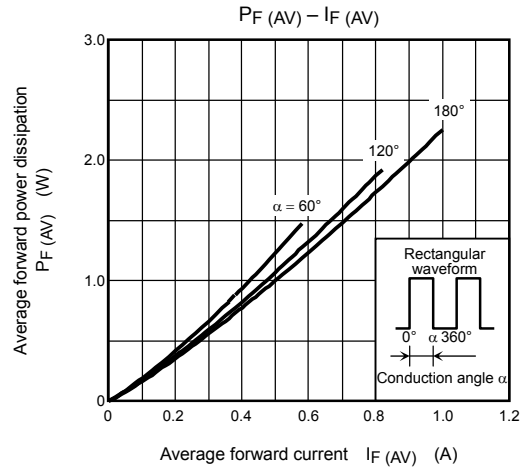
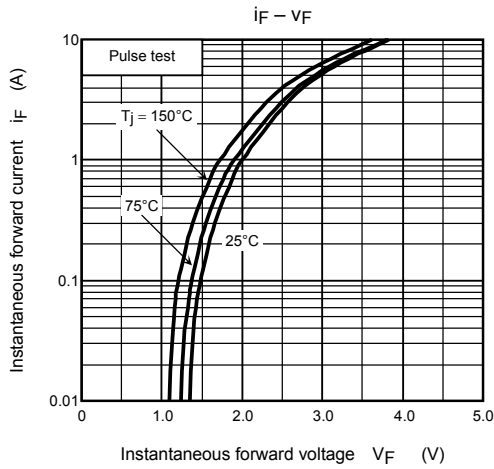

RESTRICTIONS ON PRODUCT USE

20070701-EN

- The information contained herein is subject to change without notice.
- TOSHIBA is continually working to improve the quality and reliability of its products. Nevertheless, semiconductor devices in general can malfunction or fail due to their inherent electrical sensitivity and vulnerability to physical stress. It is the responsibility of the buyer, when utilizing TOSHIBA products, to comply with the standards of safety in making a safe design for the entire system, and to avoid situations in which a malfunction or failure of such TOSHIBA products could cause loss of human life, bodily injury or damage to property.
In developing your designs, please ensure that TOSHIBA products are used within specified operating ranges as set forth in the most recent TOSHIBA products specifications. Also, please keep in mind the precautions and conditions set forth in the "Handling Guide for Semiconductor Devices," or "TOSHIBA Semiconductor Reliability Handbook" etc.
- The TOSHIBA products listed in this document are intended for usage in general electronics applications (computer, personal equipment, office equipment, measuring equipment, industrial robotics, domestic appliances, etc.). These TOSHIBA products are neither intended nor warranted for usage in equipment that requires extraordinarily high quality and/or reliability or a malfunction or failure of which may cause loss of human life or bodily injury ("Unintended Usage"). Unintended Usage include atomic energy control instruments, airplane or spaceship instruments, transportation instruments, traffic signal instruments, combustion control instruments, medical instruments, all types of safety devices, etc.. Unintended Usage of TOSHIBA products listed in this document shall be made at the customer's own risk.
- The products described in this document shall not be used or embedded to any downstream products of which manufacture, use and/or sale are prohibited under any applicable laws and regulations.
- Please contact your sales representative for product-by-product details in this document regarding RoHS compatibility. Please use these products in this document in compliance with all applicable laws and regulations that regulate the inclusion or use of controlled substances. Toshiba assumes no liability for damage or losses occurring as a result of noncompliance with applicable laws and regulations.