

Schottky Rectifier Diodes

KBR0520LW/0530W/0540W

(MBR0520LW/0530W/0540W)

■ Features

- Low forward voltage drop
- Guard ring construction for Transient protection.
- High conductance.
- Also available in lead free version.

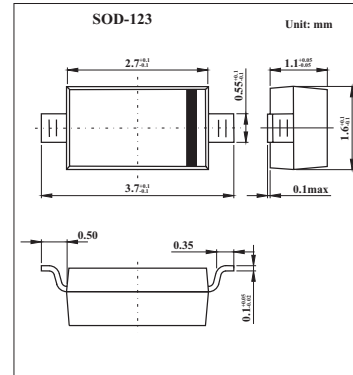

■ Absolute Maximum Ratings Ta = 25°C

Parameter	Symbol	KBR0520LW	KBR0530W	KBR0540W	Unit
Peak repetitive peak reverse voltage	VRRM				
Working peak	VRWM	20	30	40	V
DC blocking voltage	VR				
RMS reverse voltage	VR(RMS)	14	21	28	V
Average rectified output current	Io	500			mA
Peak forward surge current	IFSM	5.5			A
Power dissipation	Pd	410			mW
Voltage rate of change	dv/dt	1000			V/μs
Thermal resistance junction to ambient	RθJA	304			°C/W
Storage temperature	Tstg	-65 to +125			°C

■ Electrical Characteristics Ta = 25°C

Parameter	Symbol	Test conditions	Min	Typ	Max	Unit
Minimum Reverse Breakdown Voltage	KBR0520LW	IR=250 μA	20			V
	KBR0530W	IR=200 μA	30			
	KBR0540W	IR=20 μA	40			
Forward voltage	KBR0520LW	IF=0.1A	0.3			V
	KBR0530W		0.375			
Forward voltage	KBR0520LW	IF=0.5A	0.375			V
	KBR0530W		0.430			
	KBR0540W		0.510			
Forward voltage	KBR0540W	IF=1A	0.62			V
Reverse current	KBR0520LW	IR1 VR=10V	75			μA
	KBR0530W	IR2 VR=15V	20			μA
Reverse current	KBR0520LW	IR3 VR=20V	250			μA
	KBR0540W		10			μA
Reverse current	KBR0530W	IR4 VR=30V	130			μA
	KBR0540W	IR5 VR=40V	20			μA
Capacitance between terminals	CT	VR=0V, f=1MHz	170			pF

■ Marking

NO.	KBR0520LW	KBR0530W	KBR0540W
Marking	SD	SE	SF

KBR0520LW/0530W/0540W (MBR0520LW/0530W/0540W)

■ Typical Characteristics

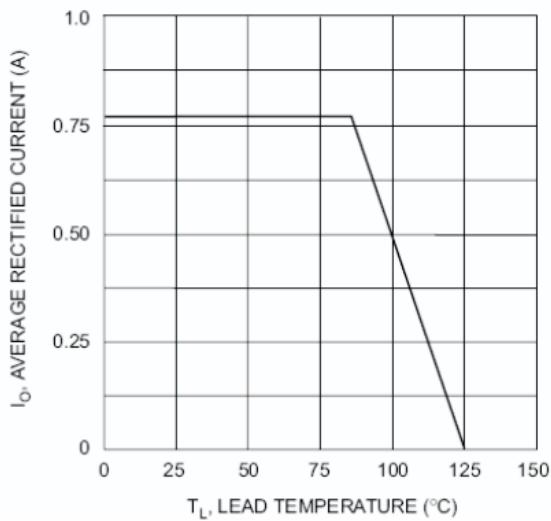

Fig.1 Forward Current Derating Curve

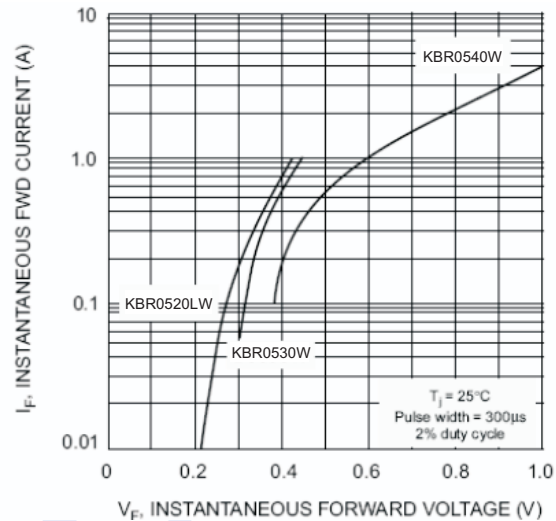

Fig.2 Typical Forward Characteristics

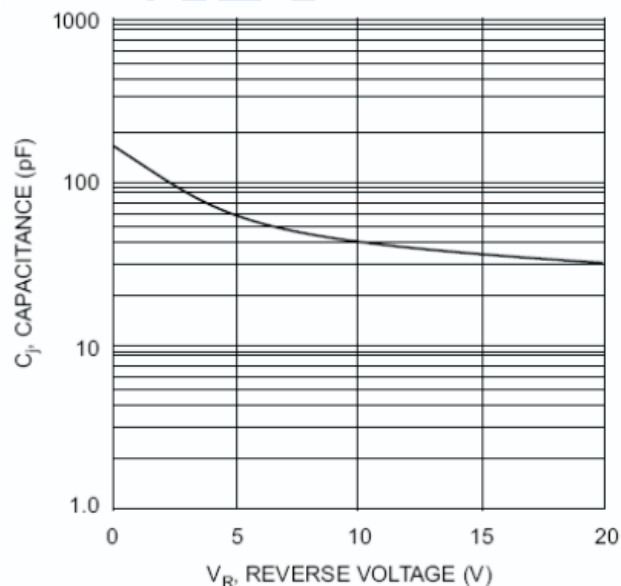

Fig.3 Typ. Junction Capacitance vs Reverse Voltage