

# DDR SDRAM UDIMM

MT9VDDT1672A – 128MB<sup>1</sup>  
 MT9VDDT3272A – 256MB  
 MT9VDDT6472A – 512MB

For component data sheets, refer to Micron's Web site: [www.micron.com](http://www.micron.com)

## Features

- 184-pin, unbuffered dual in-line memory module (UDIMM)
- Fast data transfer rates: PC2100, PC2700, or PC3200
- 128MB (16 Meg x 72), 256MB (32 Meg x 72), and 512MB (64 Meg x 72)
- Supports ECC error detection and correction
- VDD = VDDQ = +2.5V (-40B: VDD = VDDQ)
- VDDSPD = +2.3V to +3.6V
- 2.5V I/O (SSTL\_2-compatible)
- Internal, pipelined double data rate (DDR) architecture; 2n-prefetch architecture
- Bidirectional data strobe (DQS) transmitted/received with data—that is, source-synchronous data capture
- Differential clock inputs (CK and CK#)
- Multiple internal device banks for concurrent operation
- Single rank
- Selectable burst lengths (BL): 2, 4, or 8
- Auto precharge option
- Auto refresh and self refresh modes: 128MB, 15.625µs; 256MB and 512MB, 7.8125µs maximum average periodic refresh interval
- Serial presence-detect (SPD) with EEPROM
- Selectable CAS latency (CL) for maximum compatibility
- Gold edge contacts

Figure 1: 184-Pin UDIMM (MO-206)

PCB height: 31.75mm (1.25in)

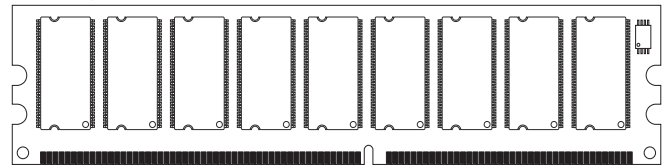

## Options

## Marking

- Operating temperature<sup>2</sup>
  - Commercial (0°C ≤ T<sub>A</sub> ≤ +70°C) None
  - Industrial (-40°C ≤ T<sub>A</sub> ≤ +85°C) I
- Package
  - 184-pin DIMM (standard) G
  - 184-pin DIMM (Pb-free) Y
- Memory clock, speed, CAS latency
  - 5.0ns (200 MHz), 400 MT/s, CL = 3 -40B
  - 6.0ns (167 MHz), 333 MT/s, CL = 2.5 -335
  - 7.5ns (133 MHz), 266 MT/s, CL = 2<sup>3</sup> -262
  - 7.5ns (133 MHz), 266 MT/s, CL = 2<sup>3</sup> -26A
  - 7.5ns (133 MHz), 266 MT/s, CL = 2.5<sup>3</sup> -265

- Notes: 1. End of life.  
 2. Contact Micron for industrial temperature module offerings.  
 3. Not recommended for new designs.

Table 1: Key Timing Parameters

Speed Grade	Industry Nomenclature	Data Rate (MT/s)			t <sub>RCD</sub> (ns)	t <sub>RP</sub> (ns)	t <sub>RC</sub> (ns)	Notes
		CL = 3	CL = 2.5	CL = 2				
-40B	PC3200	400	333	266	15	15	55	
-335	PC2700	–	333	266	18	18	60	1
-262	PC2100	–	266	266	15	15	60	
-26A	PC2100	–	266	266	20	20	65	
-265	PC2100	–	266	200	20	20	65	

Notes: 1. The values of t<sub>RCD</sub> and t<sub>RP</sub> for -335 modules show 18ns to align with industry specifications; actual DDR SDRAM device specifications are 15ns.



**Table 2: Addressing**

Parameter	128MB	256MB	512MB
Refresh count	4K	8K	8K
Row address	4K (A0–A11)	8K (A0–A12)	8K (A0–A12)
Device bank address	4 (BA0, BA1)	4 (BA0, BA1)	4 (BA0, BA1)
Device configuration	128Mb (16 Meg x 8)	256Mb (32 Meg x 8)	512Mb (64 Meg x 8)
Column address	1K (A0–A9)	1K (A0–A9)	2K (A0–A9, A11)
Module rank address	1 (S0#)	1 (S0#)	1 (S0#)

**Table 3: Part Numbers and Timing Parameters – 128MB**

Base device: MT46V16M8,<sup>1</sup> 128Mb DDR SDRAM

Part Number <sup>2</sup>	Module Density	Configuration	Module Bandwidth	Memory Clock/ Data Rate	Clock Cycles (CL- <sup>t</sup> RCD- <sup>t</sup> RP)
MT9VDDT1672AG-40B__	128MB	16 Meg x 72	3.2 GB/s	5.0ns/400 MT/s	3-3-3
MT9VDDT1672AG-335__	128MB	16 Meg x 72	2.7 GB/s	6.0ns/333 MT/s	2.5-3-3
MT9VDDT1672AY-335__	128MB	16 Meg x 72	2.7 GB/s	6.0ns/333 MT/s	2.5-3-3
MT9VDDT1672AG-262__	128MB	16 Meg x 72	2.1 GB/s	7.5ns/266 MT/s	2-2-2
MT9VDDT1672AG-26A__	128MB	16 Meg x 72	2.1 GB/s	7.5ns/266 MT/s	2-3-3
MT9VDDT1672AG-265__	128MB	16 Meg x 72	2.1 GB/s	7.5ns/266 MT/s	2.5-3-3
MT9VDDT1672AY-265__	128MB	16 Meg x 72	2.1 GB/s	7.5ns/266 MT/s	2.5-3-3

**Table 4: Part Numbers and Timing Parameters – 256MB**

Base device: MT46V32M8,<sup>1</sup> 256Mb DDR SDRAM

Part Number <sup>2</sup>	Module Density	Configuration	Module Bandwidth	Memory Clock/ Data Rate	Clock Cycles (CL- <sup>t</sup> RCD- <sup>t</sup> RP)
MT9VDDT3272AG-40B__	256MB	32 Meg x 72	3.2 GB/s	5.0ns/400 MT/s	3-3-3
MT9VDDT3272AY-40B__	256MB	32 Meg x 72	3.2 GB/s	5.0ns/400 MT/s	3-3-3
MT9VDDT3272AG-335__	256MB	32 Meg x 72	2.7 GB/s	6.0ns/333 MT/s	2.5-3-3
MT9VDDT3272AY-335__	256MB	32 Meg x 72	2.7 GB/s	6.0ns/333 MT/s	2.5-3-3
MT9VDDT3272AG-262__	256MB	32 Meg x 72	2.1 GB/s	7.5ns/266 MT/s	2-2-2
MT9VDDT3272AG-26A__	256MB	32 Meg x 72	2.1 GB/s	7.5ns/266 MT/s	2-3-3
MT9VDDT3272AG-265__	256MB	32 Meg x 72	2.1 GB/s	7.5ns/266 MT/s	2.5-3-3
MT9VDDT3272AY-265__	256MB	32 Meg x 72	2.1 GB/s	7.5ns/266 MT/s	2.5-3-3



**Table 5: Part Numbers and Timing Parameters – 512MB**

Base device: MT46V64M8,<sup>1</sup> 512Mb DDR SDRAM

Part Number <sup>2</sup>	Module Density	Configuration	Module Bandwidth	Memory Clock/ Data Rate	Clock Cycles (CL- <sup>t</sup> RCD- <sup>t</sup> RP)
MT9VDDT6472AG-40B__	512MB	64 Meg x 72	3.2 GB/s	5.0ns/400 MT/s	3-3-3
MT9VDDT6472AY-40B__	512MB	64 Meg x 72	3.2 GB/s	5.0ns/400 MT/s	3-3-3
MT9VDDT6472AG-335__	512MB	64 Meg x 72	2.7 GB/s	6.0ns/333 MT/s	2.5-3-3
MT9VDDT6472AY-335__	512MB	64 Meg x 72	2.7 GB/s	6.0ns/333 MT/s	2.5-3-3
MT9VDDT6472AG-262__	512MB	64 Meg x 72	2.1 GB/s	7.5ns/266 MT/s	2-2-2
MT9VDDT6472AG-265__	512MB	64 Meg x 72	2.1 GB/s	7.5ns/266 MT/s	2.5-3-3
MT9VDDT6472AY-265__	512MB	64 Meg x 72	2.1 GB/s	7.5ns/266 MT/s	2.5-3-3

- Notes:
1. Data sheets for the base devices can be found on Micron's Web site.
  2. All part numbers end with a two-place code (not shown) that designates component and PCB revisions. Consult factory for current revision codes. Example: MT9VDDT3272AY-335G4.



## Pin Assignments and Descriptions

Table 6: Pin Assignments

184-Pin DDR UDIMM Front								184-Pin DDR UDIMM Back							
Pin	Symbol	Pin	Symbol	Pin	Symbol	Pin	Symbol	Pin	Symbol	Pin	Symbol	Pin	Symbol	Pin	Symbol
1	VREF	24	DQ17	47	DQS8	70	VDD	93	Vss	116	Vss	139	Vss	162	DQ47
2	DQ0	25	DQS2	48	A0	71	NC	94	DQ4	117	DQ21	140	DM8	163	NC
3	Vss	26	Vss	49	CB2	72	DQ48	95	DQ5	118	A11	141	A10	164	VDDQ
4	DQ1	27	A9	50	Vss	73	DQ49	96	VDDQ	119	DM2	142	CB6	165	DQ52
5	DQS0	28	DQ18	51	CB3	74	Vss	97	DM0	120	VDD	143	VDDQ	166	DQ53
6	DQ2	29	A7	52	BA1	75	CK2#	98	DQ6	121	DQ22	144	CB7	167	NC
7	VDD	30	VDDQ	53	DQ32	76	CK2	99	DQ7	122	A8	145	Vss	168	VDD
8	DQ3	31	DQ19	54	VDDQ	77	VDDQ	100	Vss	123	DQ23	146	DQ36	169	DM6
9	NC	32	A5	55	DQ33	78	DQS6	101	NC	124	Vss	147	DQ37	170	DQ54
10	NC	33	DQ24	56	DQS4	79	DQ50	102	NC	125	A6	148	VDD	171	DQ55
11	Vss	34	Vss	57	DQ34	80	DQ51	103	NC	126	DQ28	149	DM4	172	VDDQ
12	DQ8	35	DQ25	58	Vss	81	Vss	104	VDDQ	127	DQ29	150	DQ38	173	NC
13	DQ9	36	DQS3	59	BA0	82	NC	105	DQ12	128	VDDQ	151	DQ39	174	DQ60
14	DQS1	37	A4	60	DQ35	83	DQ56	106	DQ13	129	DM3	152	Vss	175	DQ61
15	VDDQ	38	VDD	61	DQ40	84	DQ57	107	DM1	130	A3	153	DQ44	176	Vss
16	CK1	39	DQ26	62	VDDQ	85	VDD	108	VDD	131	DQ30	154	RAS#	177	DM7
17	CK1#	40	DQ27	63	WE#	86	DQS7	109	DQ14	132	Vss	155	DQ45	178	DQ62
18	Vss	41	A2	64	DQ41	87	DQ58	110	DQ15	133	DQ31	156	VDDQ	179	DQ63
19	DQ10	42	Vss	65	CAS#	88	DQ59	111	NC	134	CB4	157	S0#	180	VDDQ
20	DQ11	43	A1	66	Vss	89	Vss	112	VDDQ	135	CB5	158	NC	181	SA0
21	CKE0	44	CB0	67	DQS5	90	NC	113	NC	136	VDDQ	159	DM5	182	SA1
22	VDDQ	45	CB1	68	DQ42	91	SDA	114	DQ20	137	CK0	160	Vss	183	SA2
23	DQ16	46	VDD	69	DQ43	92	SCL	115 <sup>1</sup>	NC/A12	138	CK0#	161	DQ46	184	VDDSPD

Notes: 1. Pin 115 is NC for 128MB and A12 for 256MB and 512MB.

**Table 7: Pin Descriptions**

Symbol	Type	Description
A0–A12	Input	<b>Address inputs:</b> Provide the row address for ACTIVE commands, and the column address and auto precharge bit (A10) for READ/WRITE commands, to select one location out of the memory array in the respective device bank. A10 sampled during a PRECHARGE command determines whether the PRECHARGE applies to one device bank (A10 LOW, device bank selected by BA0, BA1) or all device banks (A10 HIGH). The address inputs also provide the op-code during a MODE REGISTER SET command. BA0, BA1 define which mode register (mode register or extended mode register) is loaded during the LOAD MODE REGISTER command. A0–A11 (128MB) and A0–A12 (256MB, 512MB).
BA0, BA1	Input	<b>Bank address:</b> BA0, BA1 define the device bank to which an ACTIVE, READ, WRITE, or PRECHARGE command is being applied.
CK0, CK0#, CK1, CK1#, CK2, CK2#	Input	<b>Clock:</b> CK and CK# are differential clock inputs. All address and control input signals are sampled on the crossing of the positive edge of CK and the negative edge of CK#. Output data (DQ and DQS) is referenced to the crossings of CK and CK#.
CKE0	Input	<b>Clock enable:</b> CKE (registered HIGH) activates and CKE (registered LOW) deactivates the internal clock, input buffers, and output drivers.
DM0–DM7	Input	<b>Input data mask:</b> DM is an input mask signal for write data. Input data is masked when DM is sampled HIGH, along with that input data, during a write access. DM is sampled on both edges of DQS. Although DM pins are input-only, the DM loading is designed to match that of DQ and DQS pins.
RAS#, CAS#, WE#	Input	<b>Command inputs:</b> RAS#, CAS#, and WE# (along with S#) define the command being entered.
S0#	Input	<b>Chip selects:</b> S# enables (registered LOW) and disables (registered HIGH) the command decoder.
SA0–SA2	Input	<b>Presence-detect address inputs:</b> These pins are used to configure the presence-detect device.
SCL	Input	<b>Serial clock for presence-detect:</b> SCL is used to synchronize the presence-detect data transfer to and from the module.
CB0–CB7	I/O	Check bits.
DQ0–DQ63	I/O	<b>Data input/output:</b> Data bus.
DQS0–DQS8	I/O	<b>Data strobe:</b> Output with read data, input with write data. DQS is edge-aligned with read data, center-aligned with write data. Used to capture data.
SDA	I/O	<b>Serial presence-detect data:</b> SDA is a bidirectional pin used to transfer addresses and data into and out of the presence-detect portion of the module.
VDD/VDDQ	Supply	<b>Power supply:</b> +2.5V ±0.2V (-40B: +2.6V ±0.1V)
VDDSPD	Supply	<b>Serial EEPROM positive power supply:</b> +2.3V to +3.6V.
VREF	Supply	SSTL_2 reference voltage (VDD/2).
Vss	Supply	Ground.
NC	-	<b>No connect:</b> These pins are not connected on the module.

## Functional Block Diagram

Figure 2: Functional Block Diagram

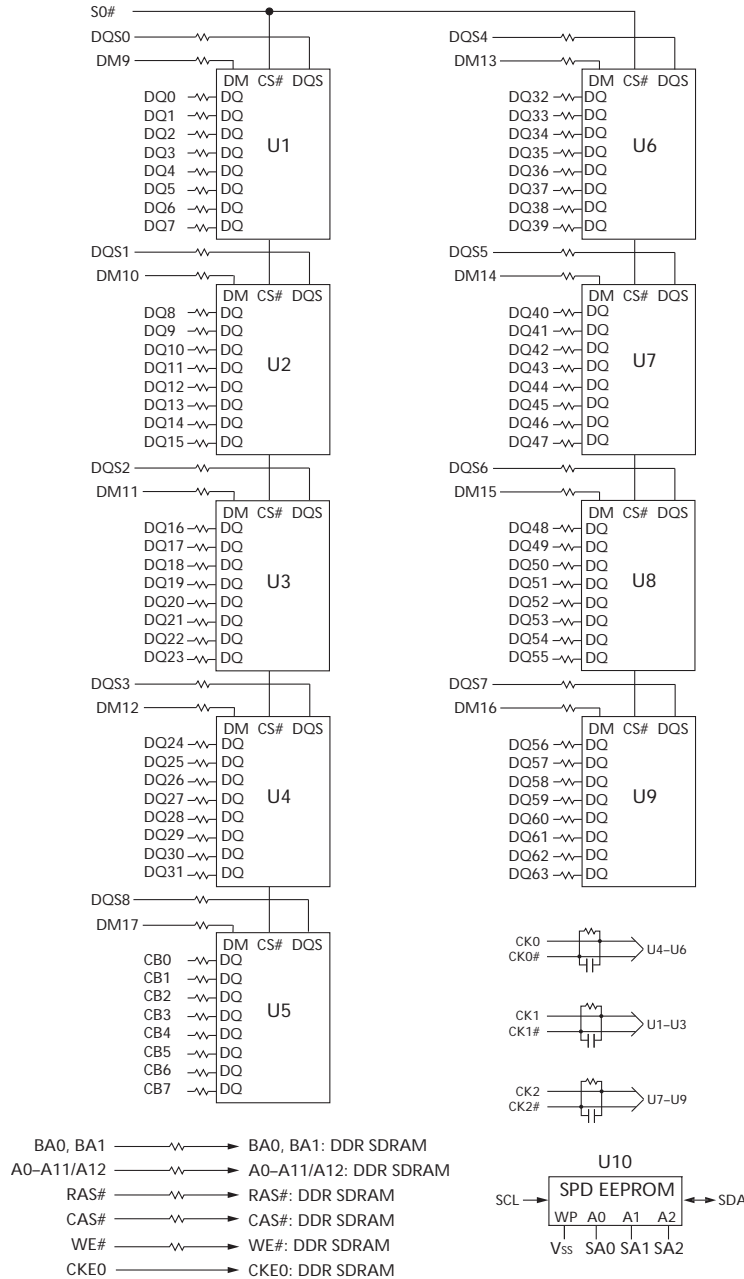

## General Description

The MT9VDDT1672A, MT9VDDT3272A, and MT9VDDT6472A are high-speed, CMOS, dynamic random access 128MB, 256MB, and 512MB memory modules organized in a x72 configuration. These modules use DDR SDRAM devices with four internal banks.

DDR SDRAM modules use a double data rate architecture to achieve high-speed operation. The double data rate architecture is essentially a  $2n$ -prefetch architecture with an interface designed to transfer two data words per clock cycle at the I/O pins. A single read or write access for DDR SDRAM modules effectively consists of a single  $2n$ -bit-wide, one-clock-cycle data transfer at the internal DRAM core and two corresponding  $n$ -bit-wide, one-half-clock-cycle data transfers at the I/O pins.

A bidirectional data strobe (DQS) is transmitted externally, along with data, for use in data capture at the receiver. DQS is a strobe transmitted by the DDR SDRAM during READs and by the memory controller during WRITEs. DQS is edge-aligned with data for READs and center-aligned with data for WRITEs.

DDR SDRAM modules operate from differential clock inputs (CK and CK#); the crossing of CK going HIGH and CK# going LOW will be referred to as the positive edge of CK. Commands are registered at every positive edge of CK. Input data is registered on both edges of DQS, and output data is referenced to both edges of DQS, as well as to both edges of CK.

## Serial Presence-Detect Operation

DDR SDRAM modules incorporate serial presence-detect (SPD). The SPD function is implemented using a 2,048-bit EEPROM. This nonvolatile storage device contains 256 bytes. The first 128 bytes are programmed by Micron to identify the module type and various SDRAM organizations and timing parameters. The remaining 128 bytes of storage are available for use by the customer. System READ/WRITE operations between the master (system logic) and the slave EEPROM device (DIMM) occur via a standard I<sup>2</sup>C bus using the DIMM's SCL (clock) and SDA (data) signals, together with SA (2:0), which provide eight unique DIMM/EEPROM addresses. Write protect (WP) is tied to VSS on the module, permanently disabling hardware write protect.

## Electrical Specifications

Stresses greater than those listed in Table 8 may cause permanent damage to the module. This is a stress rating only, and functional operation of the module at these or any other conditions outside those indicated in each device's data sheet is not implied. Exposure to absolute maximum rating conditions for extended periods may adversely affect reliability.

**Table 8: Absolute Maximum Ratings**

Symbol	Parameter	Min	Max	Units	
VDD/VDDQ	VDD/VDDQ supply voltage relative to Vss	-1.0	+3.6	V	
VIN, VOUT	Voltage on any pin relative to Vss	-0.5	+3.2	V	
II	Input leakage current; Any input $0V \leq V_{IN} \leq V_{DD}$ ; VREF input $0V \leq V_{IN} \leq 1.35V$ (All other pins not under test = 0V)	Address inputs, RAS#, CAS#, WE#, BA, S#, CKE	-18	+18	$\mu A$
		CK, CK#	-6	+6	
		DM	-2	+2	
Ioz	Output leakage current; $0V \leq V_{OUT} \leq V_{DDQ}$ ; DQ are disabled	-5	+5	$\mu A$	
TA	DRAM ambient operating temperature <sup>1</sup>	Commercial	0	+70	$^{\circ}C$
		Industrial	-40	+85	$^{\circ}C$

Notes: 1. For further information, refer to technical note TN-00-08: "Thermal Applications," available on Micron's Web site.

## Input Capacitance

Micron encourages designers to simulate the performance of the module to achieve optimum values. Simulations are significantly more accurate and realistic than a gross estimation of module capacitance when inductance and delay parameters associated with trace lengths are used in simulations. JEDEC modules are currently designed using simulations to close timing budgets.

## Component AC Timing and Operating Conditions

Recommended AC operating conditions are given in the DDR component data sheets. Component specifications are available on Micron's Web site. Module speed grades correlate with component speed grades, as shown in Table 9.

**Table 9: Module and Component Speed Grades**

Module Speed Grade	Component Speed Grade
-40B	-5B
-335	-6
-262	-75E
-26A	-75Z
-265	-75





## IDD Specifications

**Table 10: IDD Specifications and Conditions – 128MB**

Values are shown for the MT46V16M8 DDR SDRAM only and are computed from values specified in the 128Mb (16 Meg x 8) component data sheet

Parameter/Condition	Symbol	-40B	-335	-262	-26A/ -265	Units	
<b>Operating one bank active-precharge current:</b> $t_{RC} = t_{RC}(\text{MIN})$ ; $t_{CK} = t_{CK}(\text{MIN})$ ; DQ, DM, and DQS inputs changing once per clock cycle; Address and control inputs changing once every two clock cycles	IDD0	1,035	1,125	990	945	mA	
<b>Operating one bank active-read-precharge current:</b> BL = 2; $t_{RC} = t_{RC}(\text{MIN})$ ; $t_{CK} = t_{CK}(\text{MIN})$ ; IOUT = 0mA; Address and control inputs changing once per clock cycle	IDD1	1,215	1,215	1,080	1,080	mA	
<b>Precharge power-down standby current:</b> All device banks idle; Power-down mode; $t_{CK} = t_{CK}(\text{MIN})$ ; CKE = LOW	IDD2P	27	27	27	27	mA	
<b>Idle standby current:</b> CS# = HIGH; All device banks idle; $t_{CK} = t_{CK}(\text{MIN})$ ; CKE = HIGH; Address and other control inputs changing once per clock cycle. VIN = VREF for DQ, DM, and DQS	IDD2F	450	405	405	360	mA	
<b>Active power-down standby current:</b> One device bank active; Power-down mode; $t_{CK} = t_{CK}(\text{MIN})$ ; CKE = LOW	IDD3P	225	225	225	180	mA	
<b>Active standby current:</b> CS# = HIGH; CKE = HIGH; One device bank active; $t_{RC} = t_{RAS}(\text{MAX})$ ; $t_{CK} = t_{CK}(\text{MIN})$ ; DQ, DM, and DQS inputs changing twice per clock cycle; Address and other control inputs changing once per clock cycle	IDD3N	450	450	450	405	mA	
<b>Operating burst READ current:</b> BL = 2; Continuous burst READs; One device bank active; Address and control inputs changing once per clock cycle; $t_{CK} = t_{CK}(\text{MIN})$ ; IOUT = 0mA	IDD4R	1,215	1,260	1,170	1,125	mA	
<b>Operating burst WRITE current:</b> BL = 2; Continuous burst WRITEs; One device bank active; Address and control inputs changing once per clock cycle; $t_{CK} = t_{CK}(\text{MIN})$ ; DQ, DM, and DQS inputs changing twice per clock cycle	IDD4W	1,395	1,260	1,125	1,080	mA	
<b>Auto refresh current</b>	$t_{REFC} = t_{RFC}(\text{MIN})$	IDD5	2,160	2,385	1,980	1,980	mA
	$t_{REFC} = 15.625\mu\text{s}$	IDD5A	54	45	45	45	mA
<b>Self refresh current:</b> CKE $\leq$ 0.2V	IDD6	36	27	27	18	mA	
<b>Operating bank interleave READ current:</b> Four device bank interleaving READs (BL = 4) with auto precharge; $t_{RC} = t_{RC}(\text{MIN})$ ; $t_{CK} = t_{CK}(\text{MIN})$ ; Address and control inputs change only during active READ or WRITE commands	IDD7	3,195	3,195	2,970	2,925	mA	

**Table 11: IDD Specifications and Conditions – 256MB**

Values are shown for the MT46V32M8 DDR SDRAM only and are computed from values specified in the 256Mb (32 Meg x 8) component data sheet

Parameter/Condition	Symbol	-40B	-335	-262	-26A/ -265	Units	
<b>Operating one bank active-precharge current:</b> $t_{RC} = t_{RC}(\text{MIN})$ ; $t_{CK} = t_{CK}(\text{MIN})$ ; DQ, DM, and DQS inputs changing once per clock cycle; Address and control inputs changing once every two clock cycles	IDD0	1,215	1,125	1,125	1,080	mA	
<b>Operating one bank active-read-precharge current:</b> BL = 4; $t_{RC} = t_{RC}(\text{MIN})$ ; $t_{CK} = t_{CK}(\text{MIN})$ ; IOUT = 0mA; Address and control inputs changing once per clock cycle	IDD1	1,530	1,530	1,440	1,305	mA	
<b>Precharge power-down standby current:</b> All device banks idle; Power-down mode; $t_{CK} = t_{CK}(\text{MIN})$ ; CKE = LOW	IDD2P	36	36	36	36	mA	
<b>Idle standby current:</b> CS# = HIGH; All device banks idle; $t_{CK} = t_{CK}(\text{MIN})$ ; CKE = HIGH; Address and other control inputs changing once per clock cycle; VIN = VREF for DQ, DM, and DQS	IDD2F	540	450	405	405	mA	
<b>Active power-down standby current:</b> One device bank active; Power-down mode; $t_{CK} = t_{CK}(\text{MIN})$ ; CKE = LOW	IDD3P	360	270	225	225/ 270	mA	
<b>Active standby current:</b> CS# = HIGH; CKE = HIGH; One device bank active; $t_{RC} = t_{RAS}(\text{MAX})$ ; $t_{CK} = t_{CK}(\text{MIN})$ ; DQ, DM, and DQS inputs changing twice per clock cycle; Address and other control inputs changing once per clock cycle	IDD3N	630	540	450	450	mA	
<b>Operating burst READ current:</b> BL = 2; Continuous burst READs; One device bank active; Address and control inputs changing once per clock cycle; $t_{CK} = t_{CK}(\text{MIN})$ ; IOUT = 0mA	IDD4R	1,800	1,575	1,350	1,350	mA	
<b>Operating burst WRITE current:</b> BL = 2; Continuous burst WRITEs; One device bank active; Address and control inputs changing once per clock cycle; $t_{CK} = t_{CK}(\text{MIN})$ ; DQ, DM, and DQS inputs changing twice per clock cycle	IDD4W	1,755	1,575	1,350	1,350	mA	
<b>Auto refresh current</b>	$t_{REFC} = t_{RFC}(\text{MIN})$	IDD5	2,340	2,295	2,115	2,115/ 2,205	mA
	$t_{REFC} = 7.8125\mu\text{s}$	IDD5A	54	54	54	54	mA
<b>Self refresh current:</b> CKE $\leq$ 0.2V	IDD6	36	36	36	36	mA	
<b>Operating bank interleave READ current:</b> Four device bank interleaving READs (BL = 4) with auto precharge; $t_{RC} = t_{RC}(\text{MIN})$ ; $t_{CK} = t_{CK}(\text{MIN})$ ; Address and control inputs change only during active READ or WRITE commands	IDD7	4,230	3,690	3,150	3,150/ 3,285	mA	



**Table 12: IDD Specifications and Conditions – 512MB**

Values are shown for the MT46V64M8 DDR SDRAM only and are computed from values specified in the 512Mb (64 Meg x 8) component data sheet

Parameter/Condition	Symbol	-40B	-335	-262	-26A/ -265	Units	
<b>Operating one bank active-precharge current:</b> $t_{RC} = t_{RC}(\text{MIN})$ ; $t_{CK} = t_{CK}(\text{MIN})$ ; DQ, DM, and DQS inputs changing once per clock cycle; Address and control inputs changing once every two clock cycles	IDD0	1,395	1,170	1,170	1,035	mA	
<b>Operating one bank active-read-precharge current:</b> BL = 4; $t_{RC} = t_{RC}(\text{MIN})$ ; $t_{CK} = t_{CK}(\text{MIN})$ ; IOUT = 0mA; Address and control inputs changing once per clock cycle	IDD1	1,665	1,440	1,440	1,305	mA	
<b>Precharge power-down standby current:</b> All device banks idle; Power-down mode; $t_{CK} = t_{CK}(\text{MIN})$ ; CKE = LOW	IDD2P	45	45	45	45	mA	
<b>Idle standby current:</b> CS# = HIGH; All device banks idle; $t_{CK} = t_{CK}(\text{MIN})$ ; CKE = HIGH; Address and other control inputs changing once per clock cycle; VIN = VREF for DQ, DM, and DQS	IDD2F	495	405	405	360	mA	
<b>Active power-down standby current:</b> One device bank active; Power-down mode; $t_{CK} = t_{CK}(\text{MIN})$ ; CKE = LOW	IDD3P	405	315	315	270	mA	
<b>Active standby current:</b> CS# = HIGH; CKE = HIGH; One device bank active; $t_{RC} = t_{RAS}(\text{MAX})$ ; $t_{CK} = t_{CK}(\text{MIN})$ ; DQ, DM, and DQS inputs changing twice per clock cycle; Address and other control inputs changing once per clock cycle	IDD3N	540	450	450	405	mA	
<b>Operating burst READ current:</b> BL = 2; Continuous burst READs; One device bank active; Address and control inputs changing once per clock cycle; $t_{CK} = t_{CK}(\text{MIN})$ ; IOUT = 0mA	IDD4R	1,710	1,485	1,485	1,305	mA	
<b>Operating burst WRITE current:</b> BL = 2; Continuous burst WRITEs; One device bank active; Address and control inputs changing once per clock cycle; $t_{CK} = t_{CK}(\text{MIN})$ ; DQ, DM, and DQS inputs changing twice per clock cycle	IDD4W	1,755	1,575	1,395	1,215	mA	
<b>Auto refresh current</b>	$t_{REFC} = t_{RFC}(\text{MIN})$	IDD5	3,105	2,610	2,610	2,520	mA
	$t_{REFC} = 7.8125\mu\text{s}$	IDD5A	99	90	90	90	mA
<b>Self refresh current:</b> CKE $\leq$ 0.2V	IDD6	45	45	45	45	mA	
<b>Operating bank interleave READ current:</b> Four device bank interleaving READs (BL = 4) with auto precharge; $t_{RC} = t_{RC}(\text{MIN})$ ; $t_{CK} = t_{CK}(\text{MIN})$ ; Address and control inputs change only during active READ or WRITE commands	IDD7	4,050	3,645	3,600	3,150	mA	

## Serial Presence-Detect

**Table 13: Serial Presence-Detect EEPROM DC Operating Conditions**

Parameter/Condition	Symbol	Min	Max	Units
Supply voltage	VDDSPD	2.3	3.6	V
Input high voltage: Logic 1; All inputs	V <sub>IH</sub>	VDDSPD × 0.7	VDDSPD + 0.5	V
Input low voltage: Logic 0; All inputs	V <sub>IL</sub>	-1.0	VDDSPD × 0.3	V
Output low voltage: I <sub>OUT</sub> = 3mA	V <sub>OL</sub>	-	0.4	V
Input leakage current: V <sub>IN</sub> = GND to V <sub>DD</sub>	I <sub>LI</sub>	-	10	μA
Output leakage current: V <sub>OUT</sub> = GND to V <sub>DD</sub>	I <sub>LO</sub>	-	10	μA
Standby current: SCL = SDA = V <sub>DD</sub> - 0.3V; All other inputs = V <sub>SS</sub> or V <sub>DD</sub>	I <sub>SB</sub>	-	30	μA
Power supply current: SCL clock frequency = 100 kHz	I <sub>CC</sub>	-	2.0	mA

**Table 14: Serial Presence-Detect EEPROM AC Operating Conditions**

Parameter/Condition	Symbol	Min	Max	Units	Notes
SCL LOW to SDA data-out valid	t <sup>AA</sup>	0.2	0.9	μs	1
Time the bus must be free before a new transition can start	t <sup>BUF</sup>	1.3	-	μs	
Data-out hold time	t <sup>DH</sup>	200	-	ns	
Clock/data fall time	t <sup>F</sup>	-	300	ns	2
Clock/data rise time	t <sup>R</sup>	-	300	ns	2
Data-in hold time	t <sup>HD:DAT</sup>	0	-	μs	
Start condition hold time	t <sup>HD:STA</sup>	0.6	-	μs	
Clock HIGH period	t <sup>HIGH</sup>	0.6	-	μs	
Noise suppression time constant at SCL, SDA inputs	t <sub>I</sub>	-	50	ns	
Clock LOW period	t <sup>LOW</sup>	1.3	-	μs	
SCL clock frequency	f <sup>SCL</sup>	-	400	kHz	
Data-in setup time	t <sup>SU:DAT</sup>	100	-	ns	
Start condition setup time	t <sup>SU:STA</sup>	0.6	-	μs	3
Stop condition setup time	t <sup>SU:STO</sup>	0.6	-	μs	
WRITE cycle time	t <sup>WRC</sup>	-	10	ms	4

- Notes:
1. To avoid spurious start and stop conditions, a minimum delay is placed between SCL = 1 and the falling or rising edge of SDA.
  2. This parameter is sampled.
  3. For a restart condition or following a WRITE cycle.
  4. The SPD EEPROM WRITE cycle time (t<sup>WRC</sup>) is the time from a valid stop condition of a write sequence to the end of the EEPROM internal ERASE/PROGRAM cycle. During the WRITE cycle, the EEPROM bus interface circuit is disabled, SDA remains HIGH due to pull-up resistance, and the EEPROM does not respond to its slave address.

## Serial Presence-Detect Data

For the latest serial presence-detect data, refer to Micron's SPD page:  
[www.micron.com/SPD](http://www.micron.com/SPD).

## Module Dimensions

Figure 3: 184-pin DDR UDIMM

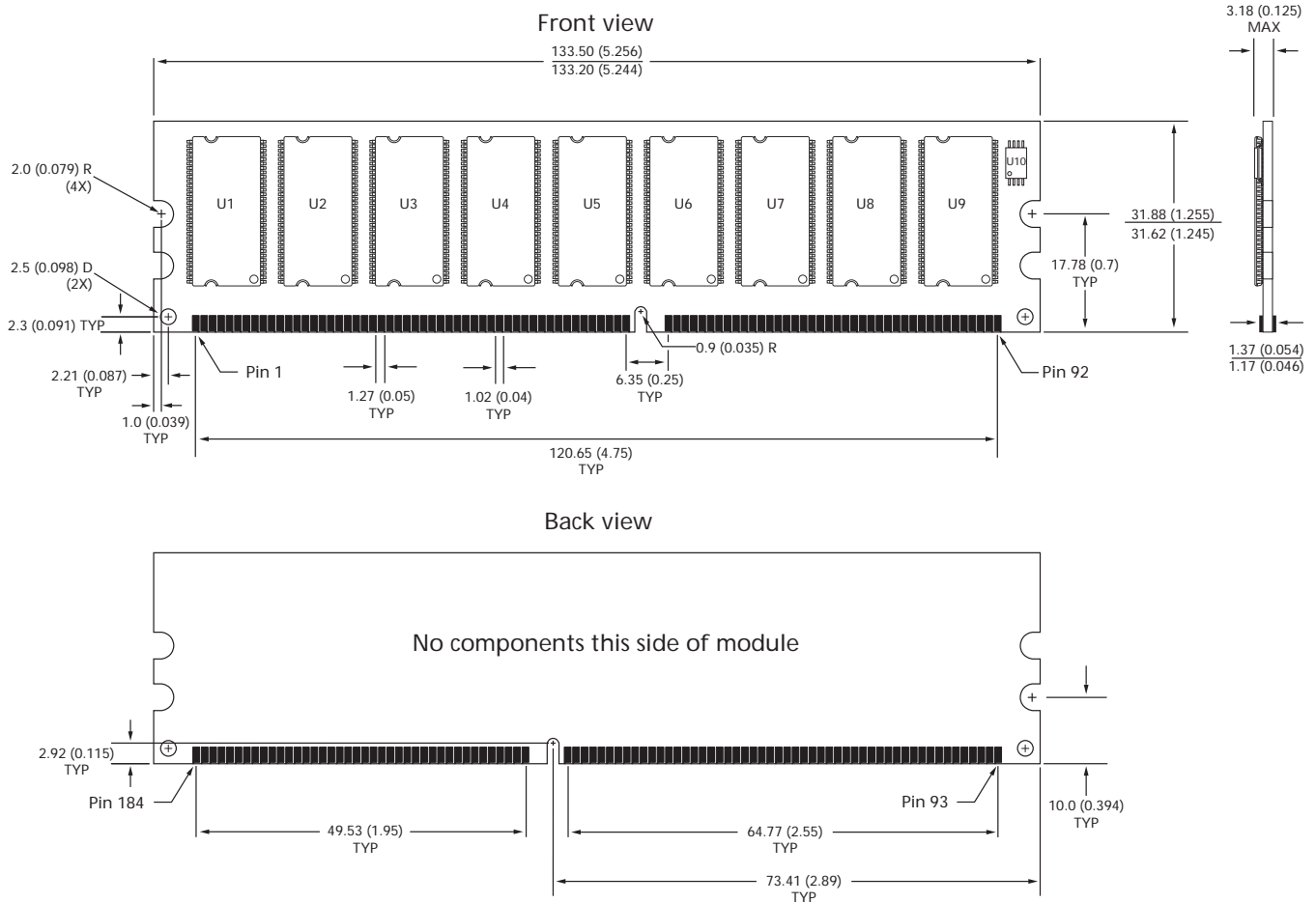

- Notes:
1. All dimensions are in millimeters (inches); MAX/MIN or typical (TYP) where noted.
  2. The dimensional diagram is for reference only. Refer to the JEDEC MO document for additional design dimensions.



8000 S. Federal Way, P.O. Box 6, Boise, ID 83707-0006, Tel: 208-368-3900  
 prodmktg@micron.com www.micron.com Customer Comment Line: 800-932-4992

Micron, the M logo, and the Micron logo are trademarks of Micron Technology, Inc. All other trademarks are the property of their respective owners.

This data sheet contains minimum and maximum limits specified over the power supply and temperature range set forth herein. Although considered final, these specifications are subject to change, as further product development and data characterization sometimes occur.