

### Analog Inputs

- $\pm 10$  Vdc current reference
- Peak, continuous current & peak-time set

### Analog Outputs

- Current monitor
- Current reference

### Digital Inputs

- Amp Enable
- Fwd/Rev Enable (limit switches)
- Hi/Lo load inductance

### Digital Outputs

- Amp OK
- Regen control
- Brake control

### Feedback

- Digital Halls from brushless motors

### Dimensions

- 53.3 x 45.7 x 15.2 mm
- 2.1 x 1.8 x 0.6 in

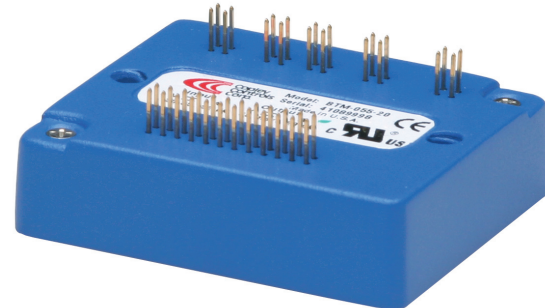

Actual Size

Model	Vdc	Ic	Ip
BTM-055-20	12~55	10	20
BTM-090-10	12~90	5	10

## DESCRIPTION

*Bantam* is a compact, DC powered analog current amplifier for torque control of DC brush or brushless motors. It operates as a stand-alone driver taking a  $\pm 10$ V input from an external controller. Mounting to a PC board with solderless connectors facilitates low-cost, multi-axis designs.

The Amp Enable input interfaces to active LO signals up to 24 Vdc. Another digital input switches the current-loop gain from a high to low for load inductance compensation. Forward and Reverse Enable inputs are provided for limit switches.

A digital output for Amp-OK indicates the amplifier's status. There are two other digital outputs one of which can activate an external

regenerative energy dissipator circuit and another for motor brake control.

Digital Hall feedback enables trapezoidal drive of DC brushless motors. For driving DC brush motors, these inputs are left unconnected and the motor connected between the U & V outputs.

Protections include I2T current limiting for peak and continuous current as well as peak time. Short circuits between outputs or to ground and amplifier over-temperature produce latching faults.

## DEVELOPMENT KIT

A Development Kit is available that provides mounting and easy connectivity for the Bantam.

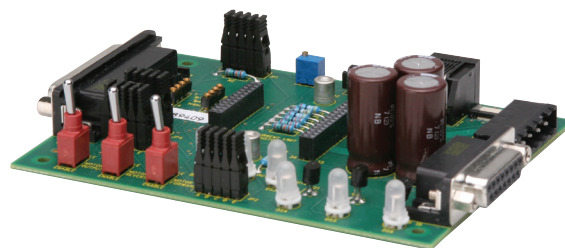

### GENERAL SPECIFICATIONS

Test conditions: Load = Wye connected load: 2 mH + 2 Ω line-line. Ambient temperature = 25°C, +HV = HV<sub>max</sub>

MODEL	BTM-055-20	BTM-090-10	
<b>OUTPUT POWER</b>			
Peak Current	20	10	Adc, ±5%
Peak time	1	1	Sec
Continuous current	10	5	Adc, ±5%
Peak Output Power	1045	855	W
Continuous Output Power	523	427	W
Output resistance	0.075	0.075	Rout (Ω)
Maximum Output Voltage	Vout = HV*0.97 - Rout*Iout		
<b>INPUT POWER</b>			
HV <sub>min</sub> to HV <sub>max</sub>	+12 to +55	+12 to +90	Vdc, Transformer-isolated
Ipeak	20	10	Adc (1 sec) peak
Icont	10	5	Adc continuous (Note 1)
<b>PWM OUTPUTS</b>			
Type	3-phase MOSFET, 33 kHz		
Commutation	Trapezoidal using digital Hall feedback		
<b>CONTROL</b>			
Analog Reference Input	±10 Vdc, 100 kΩ differential input impedance		
Bandwidths	Current loop: 2.5 kHz typical, bandwidth will vary with tuning & load inductance		
Minimum load inductance	200 μH line-line		
<b>FEEDBACK</b>			
Digital Halls	3, non-isolated, for brushless motor commutation		
Power	10 kΩ to +5 Vdc pull-up with 33 μs RC filter to 74HC14 Schmitt trigger +5 Vdc @ 250 mA max. (J1-21, 22) to power Hall sensors or commutating encoder		
<b>DIGITAL INPUTS</b>			
Number	4		
[IN1] /Enable	Amplifier enable, LO active, HI disables		
/PosEnab, /NegEnab	Forward and reverse direction limit switch/enable inputs: HI will disable output current in direction		
Type	74HC14 Schmitt trigger operating from +5 Vdc with RC filter on input Vin-LO < 1.35 Vdc, Vin-HI > 3.65 Vdc, input voltage range 0 to +24 Vdc 10 kΩ to +5 Vdc pull-up, 74HC14 Schmitt trigger operating from +5 Vdc with RC filter on input 74HCT, Vil = 0.8 Vdc max, Vih = 2.0 Vdc min, input voltage range 0 to +24 Vdc		
[LoInd] Low Inductance	HI or open: for higher inductance loads, LO or grounded: for lower inductance loads		
<b>ANALOG INPUTS</b>			
Number	5		
Ref(+), Ref(-)	Command input for output current demand, ±10 Vdc		
Peak Current Limit	0.5 to 4.80 Vdc sets peak current limit from 10~100% of rated peak current		
Continuous Current Limit	0.5 to 4.87 Vdc sets continuous current limit from 10~100% of rated continuous current		
I2T Limit	0.5 to 5.00 Vdc sets 10~100% of I2T time		
Balance	±2.5 Vdc from the 2.5 Vdc quiescent state will adjust output current ±1% of peak rated current		
<b>DIGITAL OUTPUTS</b>			
Number: type	3: N-channel MOSFET, open-drain, 30 Vdc max, 100 mA max for [AOK] and [OUT1], 1000 mA for [OUT2]		
[AOK]	Amp OK: active LO when amplifier has no faults and will operate when enabled		
[OUT1]	Configured as external regen switch controller: will be LO to turn on regen switch		
[OUT2]	Brake control (external flyback diode required): will be LO when AOK and is enabled to release brake		
<b>ANALOG OUTPUT</b>			
Current Monitor	±3.0 Vdc @ ±Ipeak		
Current Ref	Monitor for current-loop command: ±3.0 Vdc = ±100% of rated peak current		

### NOTES

1) Heatsink is required for continuous current rating.

### MOTOR CONNECTIONS

Phase U, V, W	PWM outputs to 3-phase ungrounded Wye or delta wound brushless motors, or DC brush motors (U-V)
Hall U, V, W	Digital Hall signals, single-ended
Hall power	+5 Vdc ±2% @ 250 mAdc max

### PROTECTIONS

HV Overvoltage	+HV > HV <sub>max</sub> Amplifier outputs turn off until +HV < HV <sub>max</sub> (See Input Power for HV)
HV Undervoltage	BTM-090-10: +HV < +12 Vdc, Amplifier outputs turn off until +HV > +20 Vdc BTM-055-20: +HV < +12 Vdc, Amplifier outputs turn off until +HV > +12 Vdc
Amplifier over temperature	Heat plate > 70°C
Short circuits	Output to output, output to ground, internal PWM bridge faults
I <sup>2</sup> T Current limiting	Programmable: continuous current, peak current, peak time

### MECHANICAL & ENVIRONMENTAL

Size	2.1 x 1.8 x 0.6 [53.3 x 45.7 x 15.2] in [mm]
Weight	
Ambient temperature	0 to +45 °C operating, -40 to +85 °C storage
Humidity	0 to 95%, non-condensing
Contaminants	Pollution degree 2
Environment	IEC68-2: 1990
Cooling	Conduction through heatplate on amplifier chassis, or convection

### AMPLIFIER DIMENSIONS

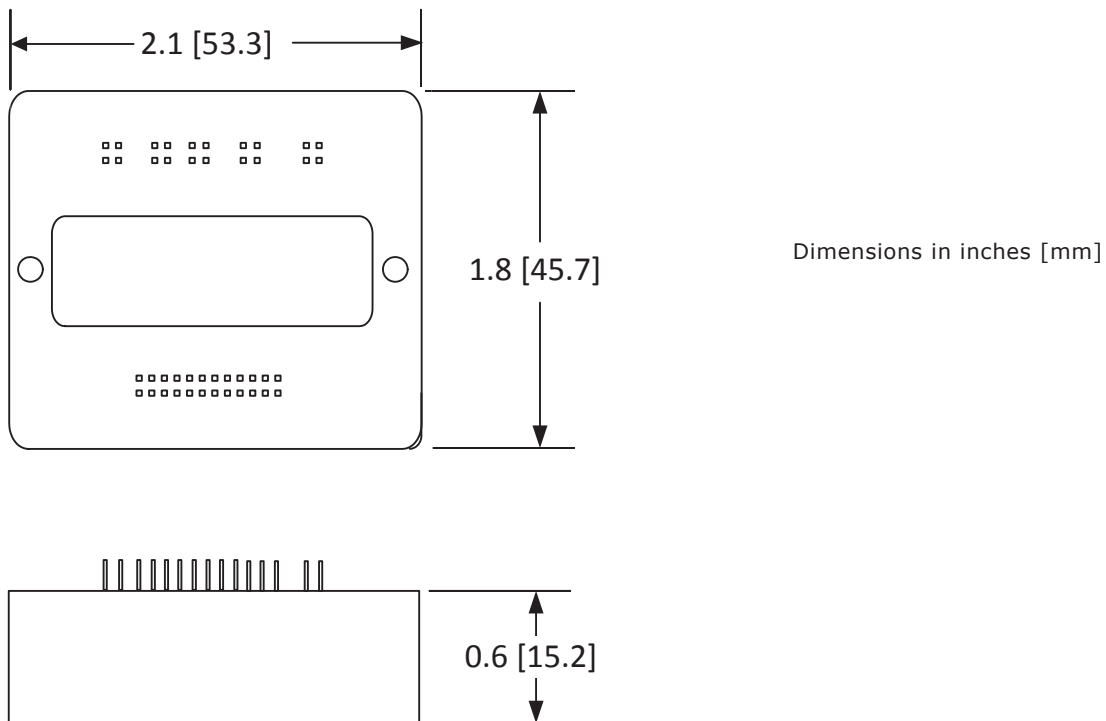

### CONTROL INPUTS AND OUTPUTS

#### ENABLE INPUT

The Enable input [IN1] is LO-active and pulled up to +5V by an internal 10k resistor. This provides fail-safe operation by disabling the amplifier if the Enable input is open, or a wire from the controller should break.

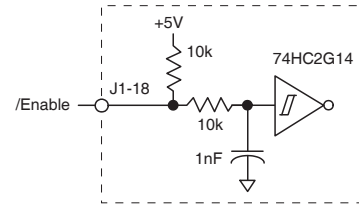

#### FWD/REV ENABLE INPUTS

Two inputs are provided for limit switches. These should be LO for normal operation, and open or HI to inhibit current of positive or negative polarity.

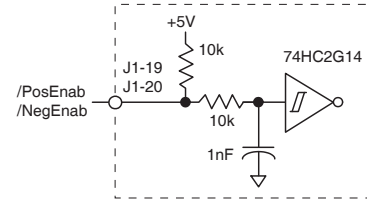

#### LOAD INDUCTANCE INPUT

The /LowInd input controls the gain of the current error amplifier to compensate the amplifier for lower or higher inductance loads. With the input open, the bandwidth will be ~2.5 kHz for a 2 mH (line-line) load. Grounding the input reduces the gain to 1/10 of the input-open gain for the same bandwidth with 200 μH loads.

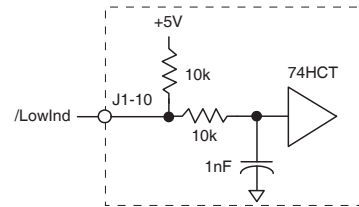

#### ANALOG REFERENCE INPUT

The amplitude and polarity of the amplifier output current is controlled by a ±10V analog signal from an external controller.

#### BALANCE INPUT

The output current of the amplifier can be adjusted to 0 Adc by connecting the balance input to a potentiometer with an adjustment range of 0 to +5 Vdc. This will produce an offset adjustment range of ±0.8% of the Ipeak rating of the amplifier. The table below shows the offset adjustment range in mA.

Model	±Ioffset (mA)
BTM-055-20	160
BTM-090-10	80

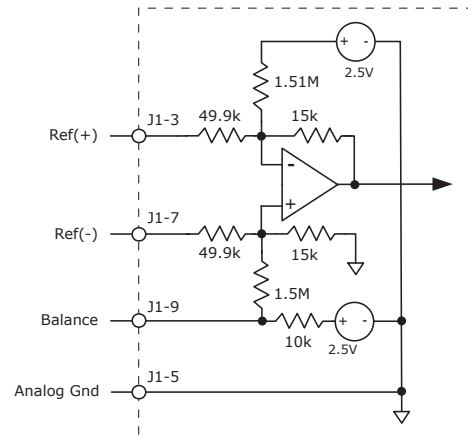

#### DIGITAL OUTPUTS

Three N-channel MOSFETs sink current from loads connecting to +30 Vdc maximum. Outputs [AOK] and [OUT1] can sink 100 mA maximum. The brake output [OUT2] can sink 1000 mA. An external flyback diode is required with driving inductive loads like a brake, or relays.

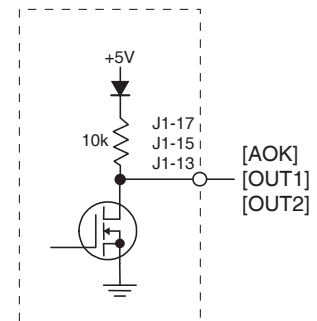

MOTOR CONNECTIONS

Motor connections are of two types for brushless motors: phases and Halls. For brush motors, only the armature connections are needed. The phase or armature connections carry the amplifier output currents that drive the motor to produce motion. The Hall signals are three digital signals used for commutating a brushless motor. When using a brush motor the Hall inputs should be unconnected and the motor armature connections made between the U & V phase outputs.

MOTOR PHASE CONNECTIONS: BRUSHLESS

The amplifier output is a three-phase PWM inverter that converts the DC buss voltage (+HV) into DC voltage waveforms that drive two motor phase-coils at a time (trapezoidal commutation). Cable should be sized for the continuous current rating of the amplifier. Motor cabling should use twisted, shielded conductors for CE compliance, and to minimize PWM noise coupling into other circuits. The motor cable shield should connect to motor frame and the equipment frame ground for best results.

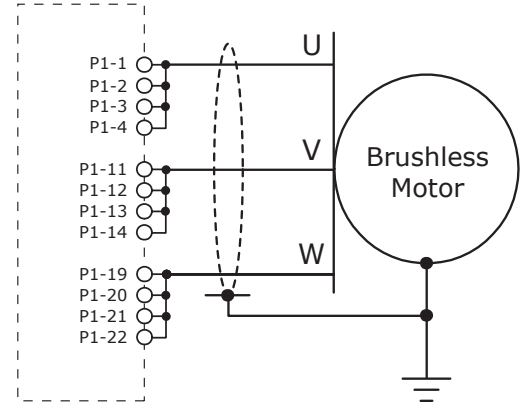

MOTOR PHASE CONNECTIONS: BRUSH

The amplifier output is an H-bridge PWM inverter that converts the DC bus voltage (+HV) into a DC voltage waveform that drives the motor armature. Cable should be sized for the continuous current rating of the amplifier. Motor cabling should use twisted, shielded conductors for CE compliance, and to minimize PWM noise coupling into other circuits. The motor cable shield should connect to motor frame and the equipment frame ground for best results.

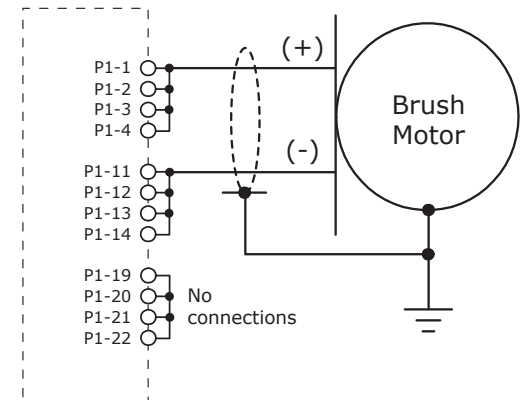

MOTOR HALL SIGNALS

Hall signals are single-ended signals that provide absolute feedback within one electrical cycle of the motor. There are three of them (U, V, & W) and they may be sourced by magnetic sensors in the motor, or by encoders that have Hall tracks as part of the encoder disc. They typically operate at much lower frequencies than the motor encoder signals, and are used for commutation. When driving DC brush motors, the Hall inputs should be left unconnected.

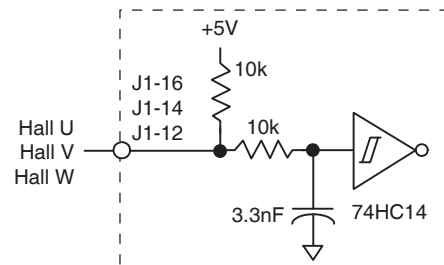

### CURRENT LIMIT INPUTS

Two inputs are provided for setting the peak and continuous current limits. The I-Peak and I-Cont inputs each have equivalent circuits shown below. Limits can be set either by applying a voltage (Vset) to the input or by connecting a resistor (Rset) between input and signal ground. The tables below show values for Rset and Vset that give 10~100% of the rated peak and continuous current ratings.

### AMPLIFIER MODELS AND RATINGS

Model	I-Peak	I-Cont	T-Peak	I2T
BTM-055-20	20	10	1	400
BTM-090-10	10	5		100

### PEAK CURRENT LIMIT SETTINGS

%	Vpeak	Rpeak
100	4.80	<OUT>
90	4.32	86400
80	3.84	38400
70	3.36	22400
60	2.88	14400
50	2.4	9600
40	1.92	6400
30	1.44	4114
20	0.96	2400
10	0.48	1067

To use the table, find the % value as follows:

$$\% = \frac{\text{PeakLimitCurrent} * 100}{\text{AmpPeak Current}}$$

### EQUIVALENT CIRCUIT

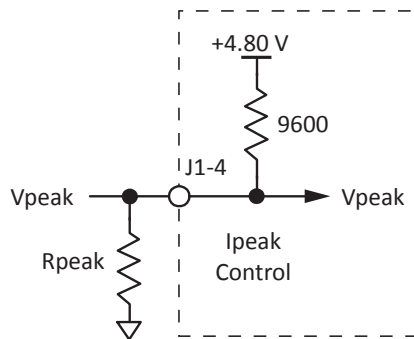

### EXAMPLE I-Peak SETTING

If a voltage Vpeak is used to control the peak-limit current, it can be found like this:

$$V_{\text{peak}} = \frac{4.80 * \text{PeakLimitCurrent}}{\text{AmpPeakCurrent}}$$

Example: find Vpeak for a 6 A PeakLimitCurrent using a BTM-090-20:

$$V_{\text{peak}} = \frac{4.80 * 6}{20} = 1.44 \text{ V}$$

To use a resistor for setting Peak-Limit current, calculate the value as follows:

$$R_{\text{peak}} = \frac{9600 * \text{PeakLimitCurrent}}{(\text{AmpPeakCurrent} - \text{PeakLimitCurrent})}$$

Example: find Rpeak for a 14 A PeakLimitCurrent:

$$R_{\text{peak}} = \frac{9600 * 14}{(20 - 14)} = 22,400 \text{ ohms}$$

### CONTINUOUS CURRENT LIMIT SETTINGS

%	Vcont	Rcont
100	4.87	<OUT>
90	4.38	88189
80	3.90	39195
70	3.41	22864
60	2.92	14698
50	2.44	9799
40	1.95	6533
30	1.46	4199
20	0.97	2450
10	0.49	1089

To use the table, find the % value as follows:

$$\% = \frac{\text{ContLimitCurrent} * 100}{\text{AmpContCurrent}}$$

### EQUIVALENT CIRCUIT

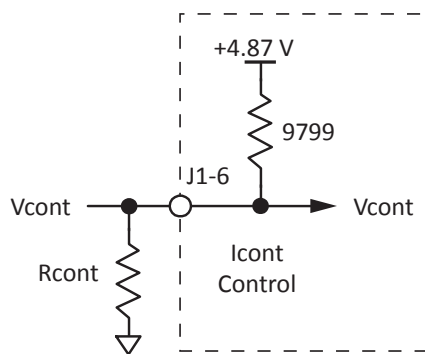

### EXAMPLE Icont SETTING

If a voltage Vcont is used to control the peak-limit current, it can be found like this:

$$V_{\text{cont}} = \frac{4.80 * \text{ContLimitCurrent}}{\text{AmpContCurrent}}$$

Example: find Vcont for a 3 A ContLimitCurrent using a BTM-090-10:

$$V_{\text{cont}} = \frac{4.87 * 3}{5} = 2.92 \text{ V}$$

To use a resistor for setting Cont-Limit current, calculate the value as follows:

$$R_{\text{cont}} = \frac{9799 * \text{ContLimitCurrent}}{(\text{AmpContCurrent} - \text{ContLimitCurrent})}$$

Example: find Rcont for a 2 A ContLimitCurrent:

$$R_{\text{cont}} = \frac{9799 * 2}{(5 - 2)} = 6,533 \text{ ohms}$$

### PWM LIMITING INPUT

#### I2T LIMIT SETTINGS

%	Vi2t	Ri2t
100	5.0	<OUT>
90	4.50	90000
80	4.00	40000
70	3.50	23333
60	3.00	15000
50	2.50	10000
40	2.00	6667
30	1.50	4286
20	1.00	2500
10	0.50	1111

#### EQUIVALENT CIRCUIT

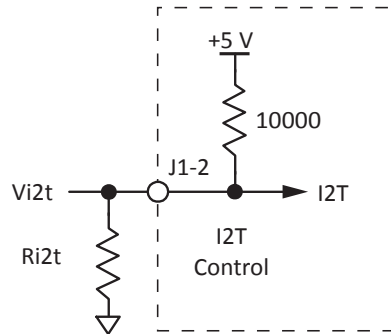

#### EXAMPLE I2T SETTING

If a voltage  $V_{peak}$  is used to control the I2T, it can be found like this:

$$Vi2t = \frac{5.0 * I2TSecs}{AmpI2TLimit}$$

Example: find Vi2t for a 6 A PeakLimitCurrent using a BTM-090-20:

$$V_{peak} = \frac{4.80 * 6}{20} = 1.44 \text{ V}$$

To use a resistor for setting Peak-Limit current, calculate the value as follows:

$$R_{peak} = \frac{9600 * PeakLimitCurrent}{(AmpPeakCurrent - PeakLimitCurrent)}$$

Example: find Rpeak for a 14 A PeakLimitCurrent:

$$R_{peak} = \frac{9600 * 14}{(20 - 14)} = 22,400 \text{ ohms}$$

#### ABOUT PWM LIMITING

PWM limiting sets a maximum value for the on vs. off time of the outputs of the amplifier. While the peak voltage seen by the load remains about the same as the supply voltage (HV), the average voltage seen by the motor can be limited. A common use of this is to limit the maximum RPM of a motor even though it's operating in torque mode.

#### PWM LIMIT SETTINGS

%	Rset (K)	Vset
97	<OUT>	4.95
78	42	4.00
70	30	3.71
68	25	3.54
62	20	3.3
57	15	2.97
45	10	2.48
38	7.5	2.12
28	5	1.65
25	2.5	0.99
25	0	0

#### EQUIVALENT CIRCUIT

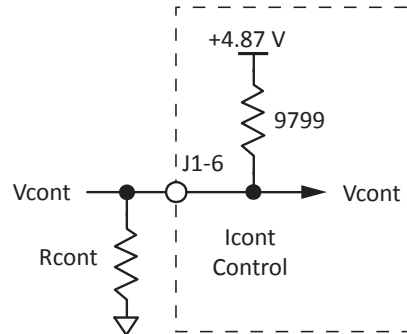

#### EXAMPLE PWM SETTING

The table shows duty cycles measured with some choices of Rset for the PWM limits.

## PC BOARD DESIGN

Printed circuit board layouts for Bantam amplifiers should follow some simple rules:

1. Install a low-ESR electrolytic capacitor not more than 12 inches from the drive. PWM amplifiers produce ripple currents in their DC supply conductors. Bantam amplifiers do not use internal electrolytic capacitors as these can be easily supplied by the printed circuit board. In order to provide a good, low-impedance path for these currents a low-ESR capacitor should be mounted as close to the drive as possible. 330  $\mu$ F is a minimum value, with a voltage rating appropriate to the drive model and power supply.

2. Connect P1 signals (U,V,W outputs, +HV, and +HV Common) in pin-groups for current-sharing. The signals on P1 are all high-current types (with the exception

of the +24 Vdc Aux HV supply). To carry these high currents (up to 20 Adc peak) the pins of P1 must be used in multiples to divide the current and keep the current carrying capacity of the connectors within specification. The diagram on page 9 shows the pin groups that must be inter-connected to act as a single connection point for pc board traces.

3. Follow IPC-2221 rules for conductor thickness and minimum trace width of P1 signals. The width and plating should depend on the model of drive used, the maximum voltage, and maximum current expected to be used for that model. Power supply traces (+HV, +HV Common) should be routed close to each other to minimize the area of the loop enclosed by the drive DC power. Noise emission or effects on nearby circuitry are proportional to the area of this loop, so minimizing it is good layout practice.

Motor signals (U,V,W) should also be routed close together. All the motor currents sum to zero, and while the instantaneous value in a given phase will change, the sum of currents will be zero. So, keeping these traces as closely placed as possible will again minimize noise radiation due to motor phase currents.

Bantam circuit grounds are electrically common, and connect internally. However, the P1 signals carry high currents while the grounds on J1 (signal ground) carry low currents. So, J1 signals should be routed away from, and never parallel to the signals on P1. Encoder signal pairs (A, /A, B, /B, and X, /X) should be routed close together for good transmission-line effect to reduce reflections and noise.

The amplifier heatplate is electrically isolated from all drive circuits. For best noise-immunity it is recommended to connect the standoffs to frame ground and to use metal mounting screws to maintain continuity between heatplate and standoffs.



PC BOARD MOUNTING FOOTPRINT

Top View  
Dimensions in inches

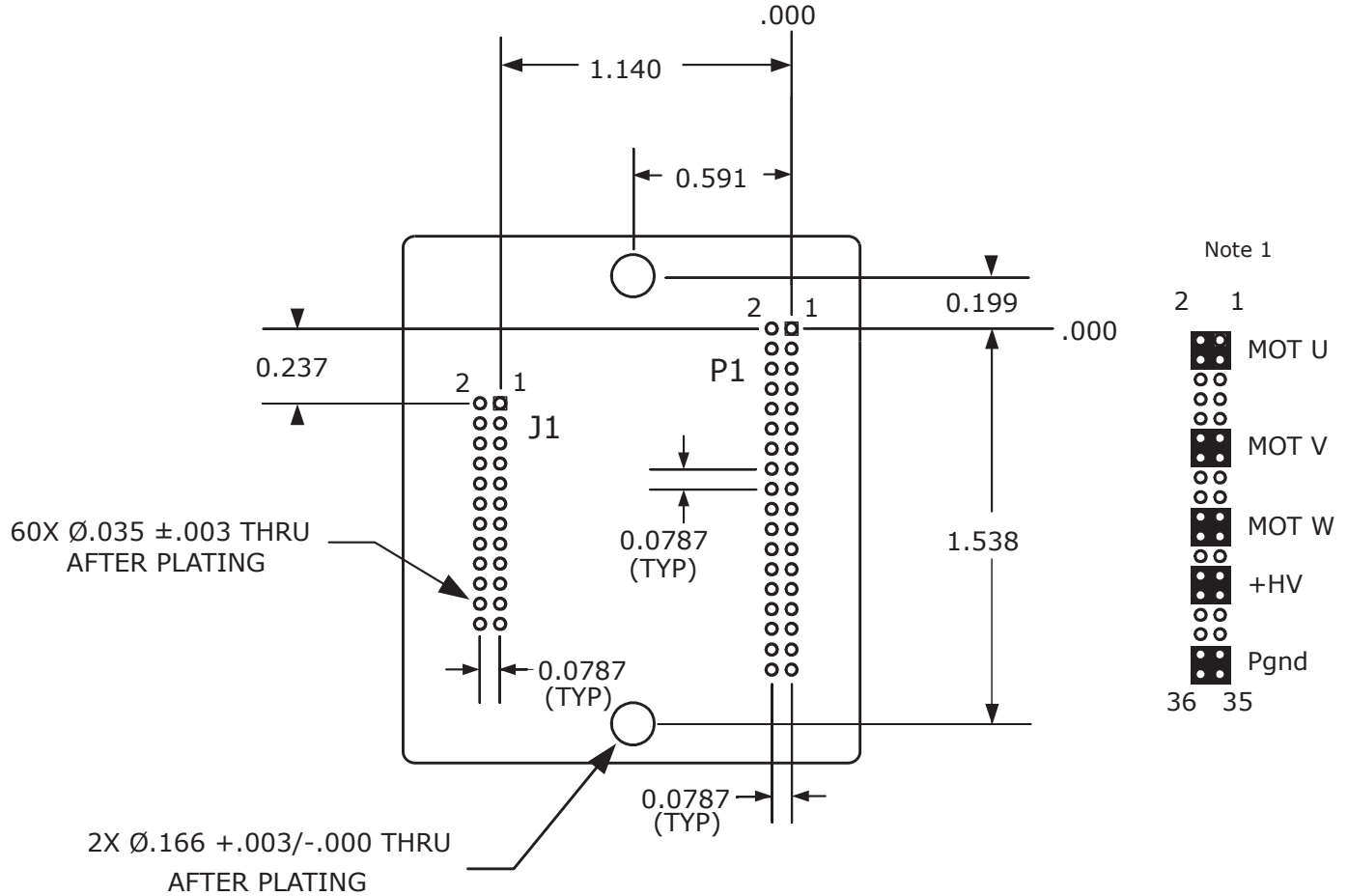

Accelnet Mounting Hardware:

Qty	Description	Mfgr	Part Number	Remarks
1	Socket Strip	Samtec	SQW-112-01-L-D	J1
1	Socket Strip	Samtec	SQW-118-01-L-D	P1

Notes

1. P1 signals must be connected for current-sharing.
2. To determine copper width and thickness for P1 signals refer to specification IPC-2221. (Association Connecting Electronic Industries, <http://www.ipc.org>)
3. Standoffs should be connected to etches on pc board that connect to frame ground for maximum noise suppression and immunity.

### AMPLIFIER PC BOARD CONNECTORS

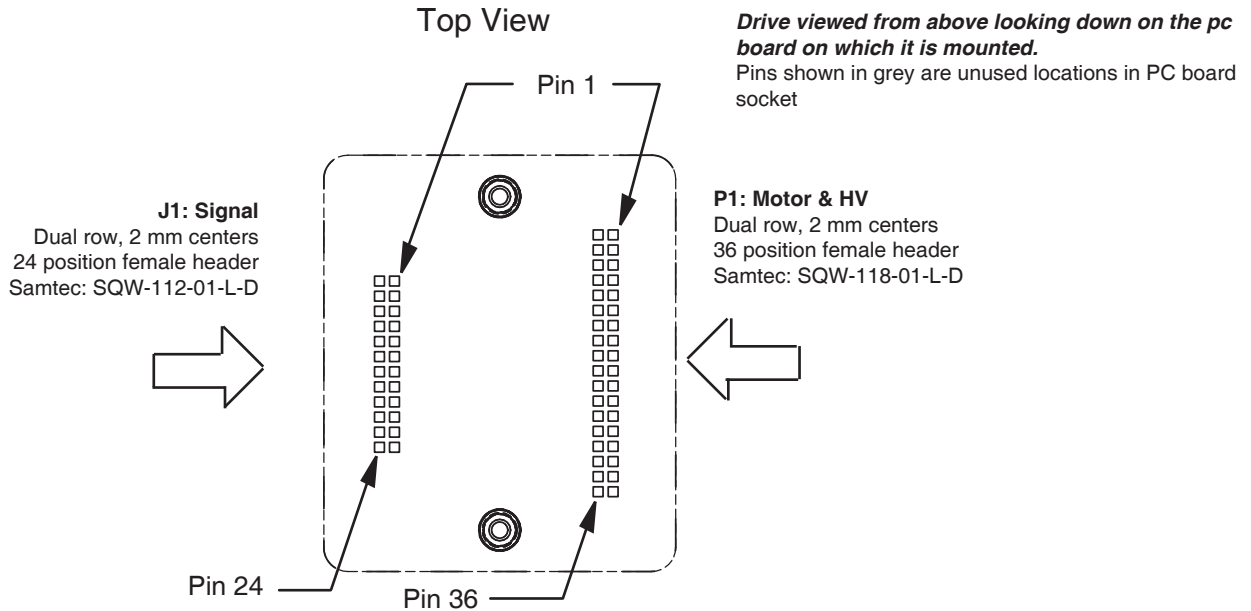

#### J1 SIGNALS & PINS

Signal	Pin	Signal
I2T Time	2	1 Current Ref
Peak Curr Limit	4	3 Ref(+)
Cont Curr Limit	6	5 Agnd
PWM Limit	8	7 Ref(-)
/LowInd	10	9 Balance
Hall W	12	11 Current Monitor
Hall V	14	13 [OUT2]
Hall U	16	15 [OUT1]
/Enable	18	17 [AOK]
/NegEnab	20	19 /PosEnab
Hall +5V	22	21 Hall +5V
Pgnd	24	23 Pgnd

#### P1 SIGNALS & PINS

Signal	Pin	Signal
Motor U	2	1 Motor U
Motor U	4	3 Motor U
N/C	6	5 N/C
N/C	8	7 N/C
N/C	10	9 N/C
Motor V	12	11 Motor V
Motor V	14	13 Motor V
N/C	16	15 N/C
N/C	18	17 N/C
Motor W	20	19 Motor W
Motor W	22	21 Motor W
N/C	24	23 N/C
Pgnd	26	25 Pgnd
Pgnd	28	27 Pgnd
N/C	30	29 N/C
N/C	32	31 N/C
+HV	34	33 +HV
+HV	36	35 +HV

#### NOTES

1. Grey-shaded signal are N.C. (No Connection)
2. Signals are grouped for current-sharing on the power connector. When laying out pc board artworks, all pins in groups having the same signal name must be connected.
3. Total output current from +5V pins (J1-21,22) cannot exceed 250 mA.

AMPLIFIER CONNECTIONS

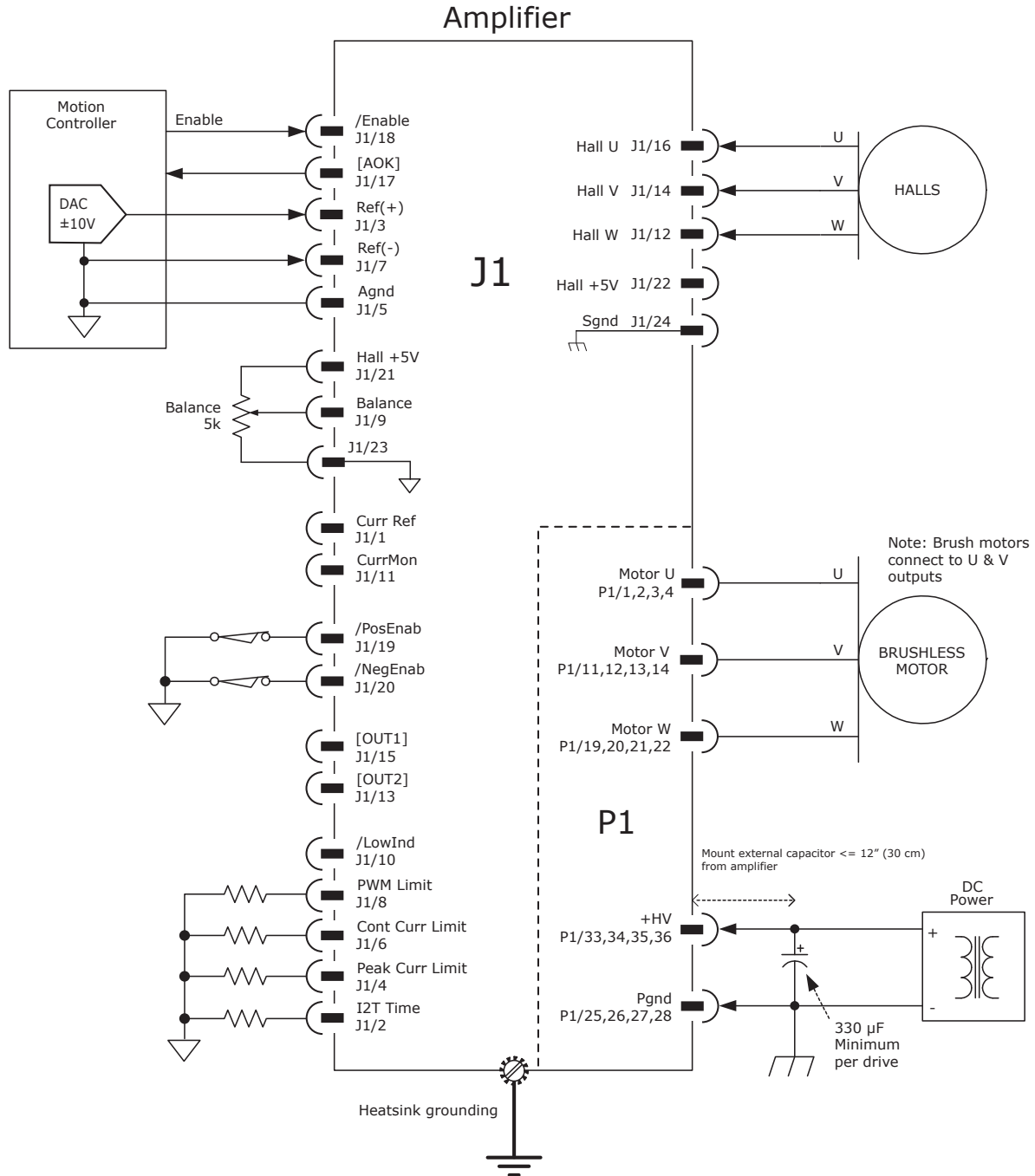

NOTES

1. Total output current from +5V pins (J1-21,22) cannot exceed 250 mA.
2. When Balance potentiometer is used, it should connect to amplifier +5V and ground for best stability.

### AMPLIFIER TEMPERATURE VS OUTPUT CURRENT AND HV AT 25C AMBIENT

The curves below use the amplifier power dissipation information and the thermal resistance of 12 °C/W without any heatsink or forced-air cooling to show quickly if a heatsink or forced-air cooling will be required. When output current is known, draw a vertical line to the curve of the supply voltage (HV) that's closes to the HV in use and mark the spot where they intersect. If the point is above the 70C line on the chart, then either a heatsink or forced-air cooling will be required. If this is the case, then use the following curves for power dissipation and thermal resistance to determine what combination of heatsinking and/or cooling would be required.

BTM-055-20

BTM-090-10

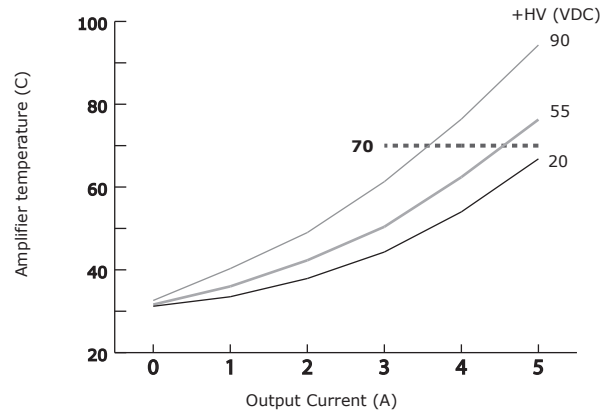
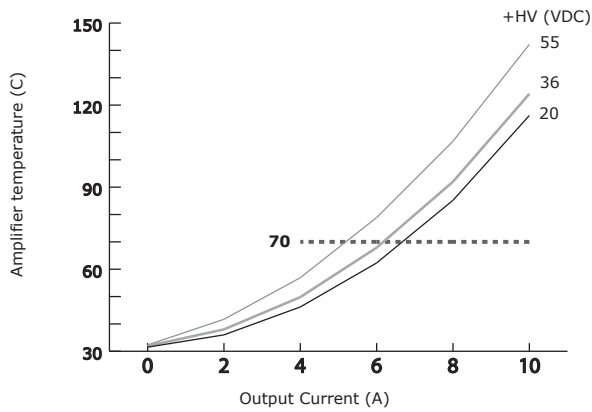

### HEATSINK AND FORCED-AIR COOLING: HOW TO FIND OUT IF THESE ARE REQUIRED

To see if a heatsink or fan-cooling is required, find the temperature rise the drive will experience when it's installed. For example, if the ambient temperature in the drive enclosure is 40 °C, and the heatplate temperature is to be limited to 70° C or less to avoid shutdown, the maximum rise would be 70C - 40C. or 30C. Then find the power dissipation in the charts below. Divide the temperature rise by the power dissipation and the result is thermal resistance in °C/W. Find this value on the Y-axis of the charts on the following page and draw horizontal lines across the charts to show what combinations of heatsink and air movement will produce this thermal resistance.

### POWER DISSIPATION VS. OUTPUT CURRENT AND HV

BTM-055-20

BTM-090-10

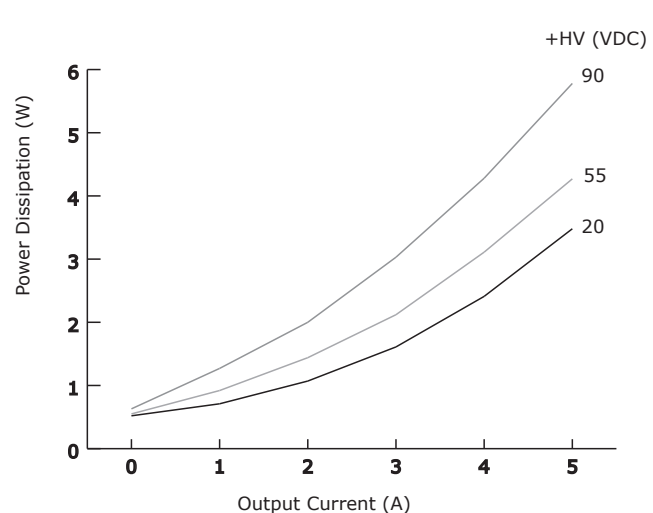
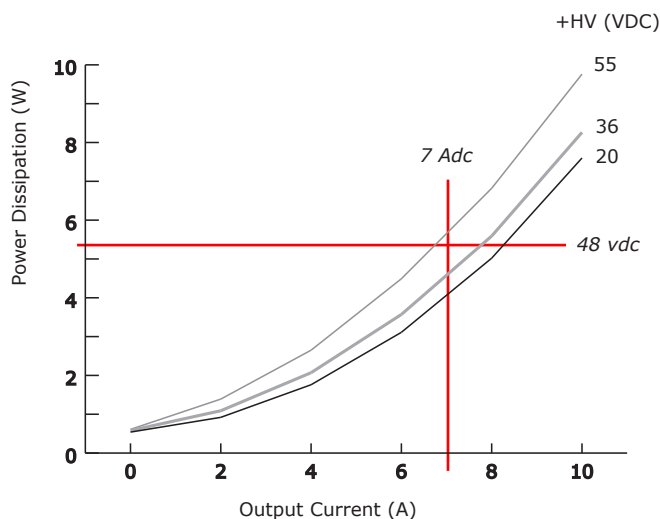

### THERMAL RESISTANCE

The temperature rise of the amplifier when operating depends on the power dissipation and the thermal resistance between the amplifier and the environment.

#### NO HEATSINK

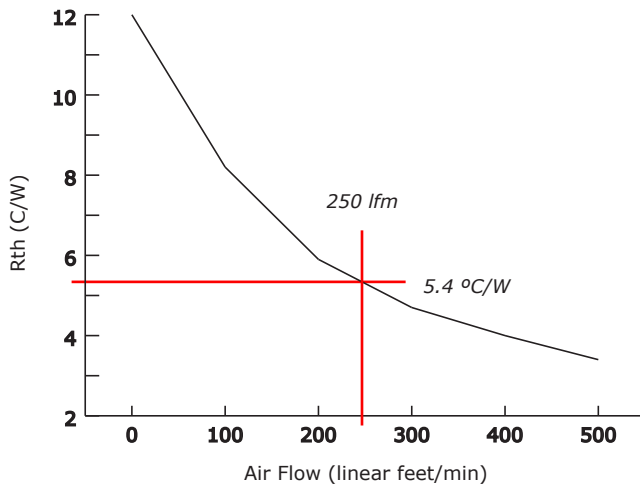

#### WITH HEATSINK

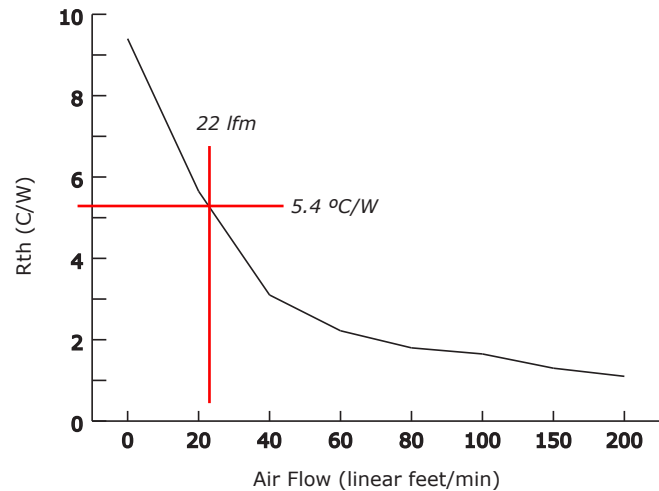

### EXAMPLE

A BTM-055-20 application needs to output 7 Adc while operating from a 48 V power supply. In the chart on p. 10, place a vertical line at the 7 Adc point. Next draw a horizontal line that intersects it at a point 2/3 of the way between the 36 & 55 V curves, estimating a 48 Vdc power supply. This line yields a power dissipation of 5.4 W. Next, draw lines at the 5.4 °C/W point on the curves above. These show that adding a heatsink reduces the air circulation requirement from 250 lfm to ~25 lfm. This low value can probably be met using a single fan in the enclosure to circulate air where it could cool multiple Bantam amplifiers adequately.

### HEATSINK INSTALLATION

If a heatsink is used it is mounted using the same type of screws used to mount the drive without a heatsink but slightly longer. Phase change material (PSM) is used in place of thermal grease. This material comes in sheet form and changes from solid to liquid form as the drive warms up. This forms an excellent thermal path from drive heatplate to heatsink for optimum heat transfer.

### STEPS TO INSTALL

1. Remove the PSM (Phase Change Material) from the clear plastic carrier.
2. Place the PSM on the *Bantam* aluminum heatplate taking care to center the PSM holes over the holes in the drive body.
3. Mount the heatsink onto the PSM again taking care to see that the holes in the heatsink, PSM, and drive all line up.
4. Torque the #4-40 mounting screws to 8~10 lb-in (0.9~1.13 N·m).

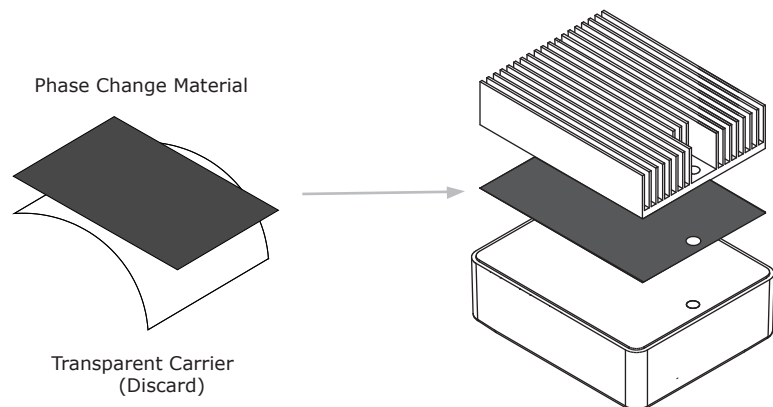

DEVELOPMENT KIT TOP VIEW

The graphic below shows the placement of components and connectors on the Development Kit PC board. The Bantam amplifier is not shown, but mounts in the outline that contains connectors J3 & J2.

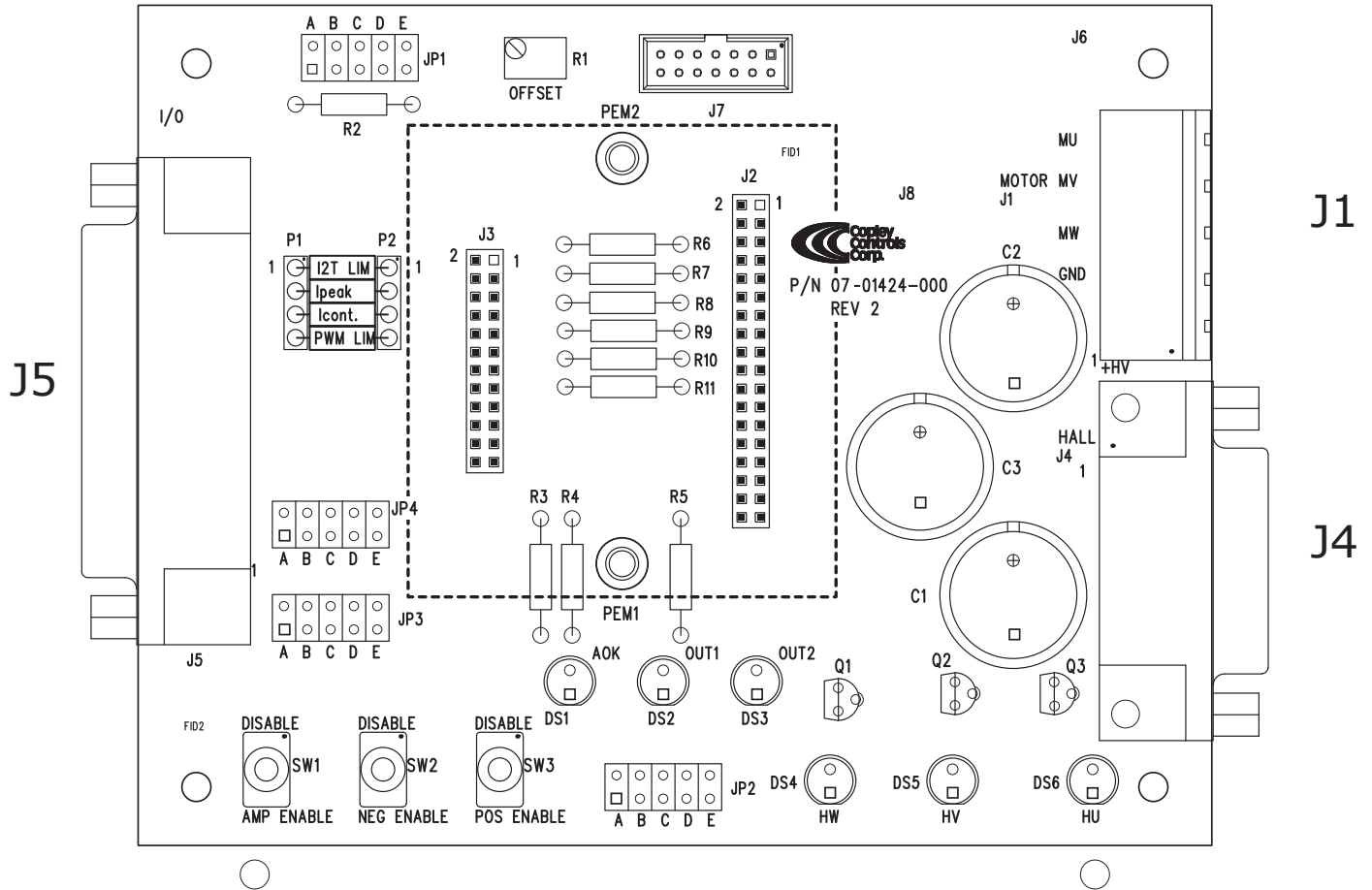

SOCKETED COMPONENTS

P1/P2	Remarks
1	I2T Time setting resistor
2	Ipeak setting resistor
3	Icont setting resistor
4	No function

## CONNECTORS

These charts show the pins and signals for the Development Kit connectors.

### J1 MOTOR AND HV POWER

Pin	Signal
5	Mot U
4	Mot V
3	Mot W
2	HV Gnd
1	+HV Input

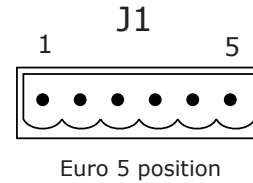

### J4 HALLS

Signal	Pin	Signal	
Sgnd	1	9	n.c.
Hall U	2	10	Sgnd
Hall V	3	11	+5 Vdc output
Hall W	4	12	Sgnd
Sgnd	5	13	n.c.
n.c.	6	14	n.c.
n.c.	7	15	n.c.
n.c.	8		

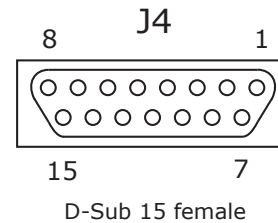

### J5 CONTROL

Signal	Pin	Signal	
Sgnd	1	14	Ref(-)
Ref(+)	2	15	Sgnd
Ext Balance	3	16	Sgnd
/NegEnab	4	17	/PosEnab
/Enable	5	18	Gain Select
[OUT1]	6	19	Sgnd
Current Cont Limit	7	20	n.c.
Current Ref	8	21	Curr Peak Limit
I2T Time	9	22	[AOK]
Current Monitor	10	23	+5 Vdc Output
[OUT2]	11	24	n.c.
Sgnd	12	25	n.c.
Sgnd	13		

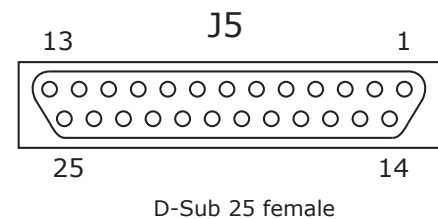

## NOTES

- 1) The combined current from J4-11 and J5-23 cannot exceed 250 mA.

CONNECTIONS

In the diagram below, connectors inside the Bantam outline are the amplifier connectors, their signal names, and pin numbers. All connectors and components outside of the Bantam are on the Development Kit.

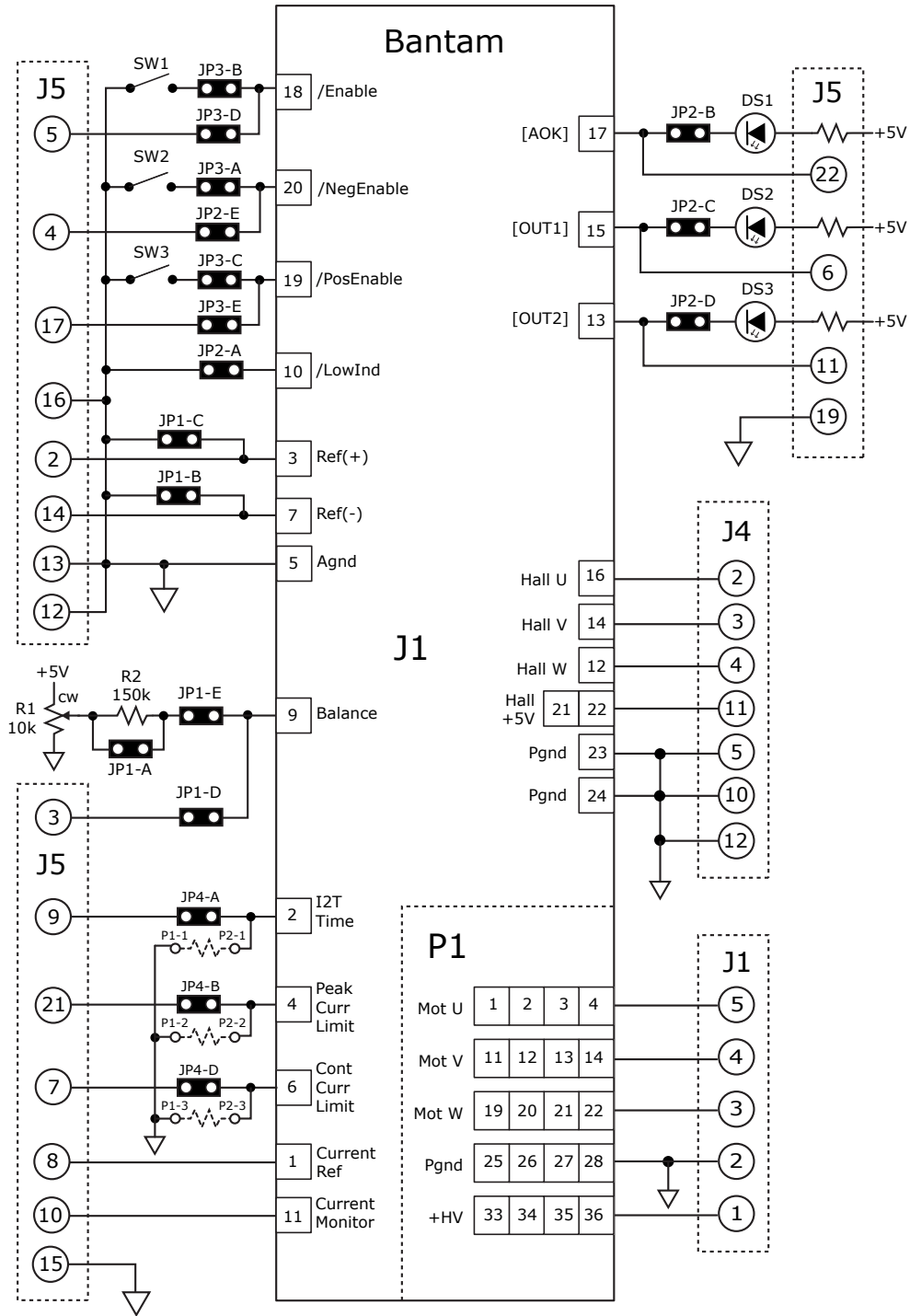

NOTES

- 1) The combined current from J4-11 and J5-23 cannot exceed 250 mA.



## JUMPER FUNCTIONS

The functions shown in the tables below are in effect when the jumper is in place.  
When a jumper is removed, the stated function is disabled.  
J5 connects to an external controller

### JP1

JP1	Remarks
A	Shorts 150k balance scaler
B	Ref(-) input is grounded
C	Ref(+) input is grounded
D	Connects J5-3 to Amp: Balance
E	R1 controls Amp: Balance

### JP2

JP2	Remarks
A	Gain Select to Sgnd
B	Amp: [AOK] drives DS1
C	Amp: [OUT1] drives DS2
D	Amp: [OUT2] drives DS3
E	Connects J5-4 to Amp: /NegEnab

### JP3

JP3	Remarks
A	Connects SW2 to Amp: /NegEnab
B	Connects SW1 to Amp: /Enable
C	Connects SW3 to Amp: /PosEnab
D	Connects J5-5 to Amp: /Enable
E	Connects J5-17 to Amp: /PosEnab

### JP4

JP4	Remarks
A	Connects J5-9 to Amp: I2T Time
B	Connects J5-21 to Amp: Current Peak Limit
C	No connections
D	Connects J5-7 to Amp: Current Cont Limit
E	Connects J5-18 to Amp: Gain Select

### MASTER ORDERING GUIDE

BTM-055-20	<i>Bantam</i> analog current amplifier, 10/20 Adc
BTM-090-10	<i>Bantam</i> analog current amplifier, 5/10 Adc
BDK-090-01	Development kit
BDK-CK	Connector Kit for Development Kit

### ORDERING EXAMPLE

Example: Order 1 BTM-055-20 current amplifier and development kit:

Qty	Item	Remarks
1	BTM-055-20	<i>Bantam</i> current amplifier
1	BDK-090-01	Development Kit for Bantam amplifier
1	BDK-CK	Connector Kit for Development Kit

### ACCESSORIES

ORDER NUMBER	Qty	Ref	DESCRIPTION
BDK-CK Connector kit for BDK-090-01 Development Kit (includes next 5 items shown below)			
	1	J1	Connector, RoHS, Euro style plug, 5 position, Tyco (AMP) 796635-5
	1	J4	Connector, D-Sub, 15-position, male, RoHS, Tyco (AMP) 5-747908-2
	1	J4	Backshell, D-Sub, RoHS, metallized, 15-position, Norcomp 979-015-020R121
	1	J5	Connector, D-Sub, 25-position, male, RoHS, Tyco (AMP) 5-747912-2
	1	J5	Backshell, D-Sub, RoHS, metallized, 25-position, Norcomp 979-025-020R121

### HEATSINK (OPTIONAL)

Heatsink Kit BTM-HK	1	Heatsink kit (for field-installation by customer)
	1	Heatsink Thermal Phase-change Material
	4	Heatsink hardware (#4-40 screws)