

■ Features :

- Universal AC input / Full range
- Protections: Short circuit / Overload / Over voltage
- Battery low protections
- Cooling by free air convection
- 100% full load burn-in test
- Fixed switching frequency at 45KHz
- 2 years warranty



SPECIFICATION

MODEL	ADD-55A			ADD-55B			
OUTPUT	OUTPUT NUMBER	CH1	CH2	CH3	CH1	CH2	CH3
	DC VOLTAGE	13.8V	5V	13.4V	27.6V	5V	26.5V
	RATED CURRENT	2.5A	3A	0.23A	1.3A	3A	0.16A
	CURRENT RANGE	0 ~ 3.5A	0 ~ 4A	-----	0 ~ 2A	0 ~ 4A	-----
	RATED POWER	52.58W			55.12W		
	RIPPLE & NOISE (max.) Note.2	100mVp-p	100mVp-p	-----	150mVp-p	150mVp-p	-----
	VOLTAGE ADJ. RANGE	CH1: 12 ~ 14.5V			CH1: 24 ~ 29V		
	VOLTAGE TOLERANCE Note.3	±1.0%	±3.0%	-----	±1.0%	±3.0%	-----
	LINE REGULATION	±1.0%	±0.5%	-----	±1.0%	±0.5%	-----
	LOAD REGULATION	±1.0%	±0.5%	-----	±1.0%	±0.5%	-----
SETUP, RISE TIME	800ms, 50ms/230VAC 1600ms, 50ms/115VAC at full load						
HOLD UP TIME (Typ.)	80ms/230VAC 16ms/115VAC at full load						
INPUT	VOLTAGE RANGE	88 ~ 264VAC 124 ~ 370VDC					
	FREQUENCY RANGE	47 ~ 63Hz					
	EFFICIENCY (Typ.)	71%			74%		
	AC CURRENT (Typ.)	1.6A/115VAC 1A/230VAC					
	INRUSH CURRENT (Typ.)	COLD START 20A/115VAC 40A/230VAC					
LEAKAGE CURRENT	<1mA / 240VAC						
PROTECTION	OVERLOAD	105 ~ 150% rated output power Protection type : Hiccup mode, recovers automatically after fault condition is removed					
	OVER VOLTAGE	CH1:14.49 ~ 18.63V			CH1:28.98 ~ 37.26V Protection type : Hiccup mode, recovers automatically after fault condition is removed		
FUNCTION	DC ALARM SIGNAL(OPTIONAL)	AC fail CN1 PIN2					
		Battery low under charge voltage 82.5%±2% CN1 PIN1 Normal 0.8V max. Abnormal 5V±0.5V					
ENVIRONMENT	WORKING TEMP.	-10 ~ +60°C (Refer to output load derating curve)					
	WORKING HUMIDITY	20 ~ 90% RH non-condensing					
	STORAGE TEMP., HUMIDITY	-20 ~ +85°C, 10 ~ 95% RH					
	TEMP. COEFFICIENT	±0.03%/°C (0 ~ 50°C) on CH1 output					
	VIBRATION	10 ~ 500Hz, 2G 10min./1cycle, 60min. each along X, Y, Z axes					
SAFETY & EMC (Note 4)	SAFETY STANDARDS	UL60950-1, TUV EN60950-1 approved					
	WITHSTAND VOLTAGE	I/P-O/P:3KVAC I/P-FG:1.5KVAC O/P-FG:0.5KVAC					
	ISOLATION RESISTANCE	I/P-O/P, I/P-FG, O/P-FG:100M Ohms / 500VDC / 25°C / 70% RH					
	EMI CONDUCTION & RADIATION	Compliance to EN55022 (CISPR22) Class B					
	HARMONIC CURRENT	Compliance to EN61000-3-2,-3					
OTHERS	EMS IMMUNITY	Compliance to EN61000-4-2,3,4,5,6,8,11; ENV50204, EN55024, light industry level, criteria A					
	MTBF	241.3K hrs min. MIL-HDBK-217F (25°C)					
NOTE	DIMENSION	159*97*38mm (L*W*H)					
	PACKING	0.57Kg; 24pcs/13.7Kg/0.75CUFT					
<p>1. All parameters NOT specially mentioned are measured at 230VAC input, rated load and 25°C of ambient temperature. 2. Ripple & noise are measured at 20MHz of bandwidth by using a 12" twisted pair-wire terminated with a 0.1uF & 47uF parallel capacitor. 3. Tolerance : includes set up tolerance, line regulation and load regulation. 4. The power supply is considered a component which will be installed into a final equipment. The final equipment must be re-confirmed that it still meets EMC directives.</p>							

Mechanical Specification

Case No. 901 Unit:mm

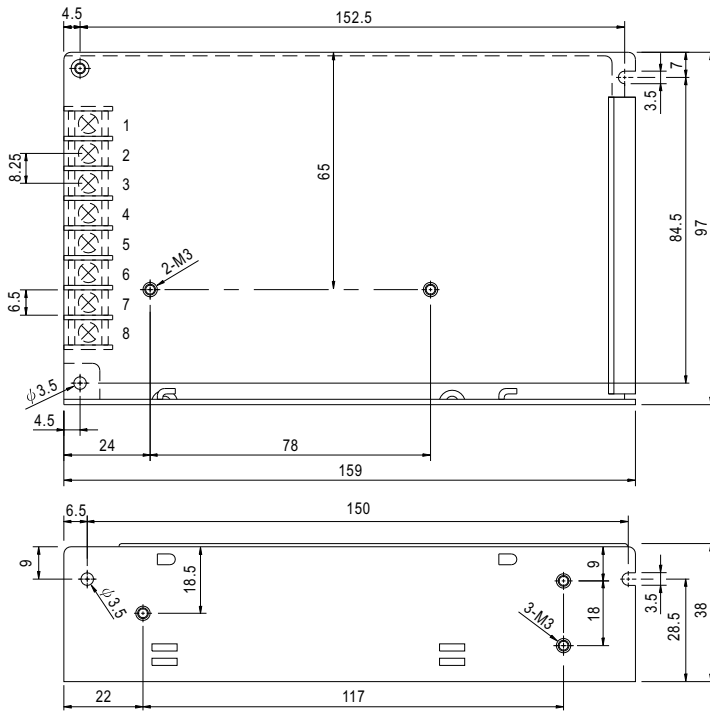

Terminal Pin No. Assignment

Pin No.	Assignment	Pin No.	Assignment
1	AC/L	5	DC OUTPUT +V
2	AC/N	6	BAT. +
3	FG \perp	7	BAT./COM
4	DC OUTPUT COM	8	DC/DC OUTPUT +5V

Block Diagram

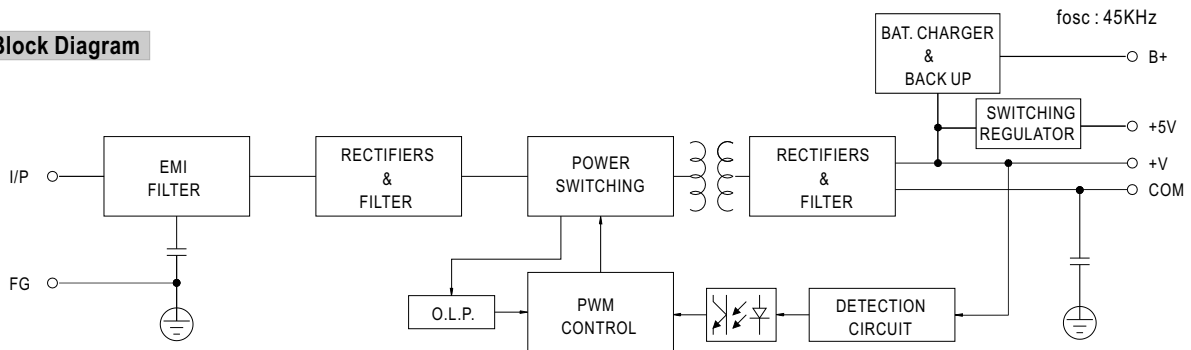

Derating Curve

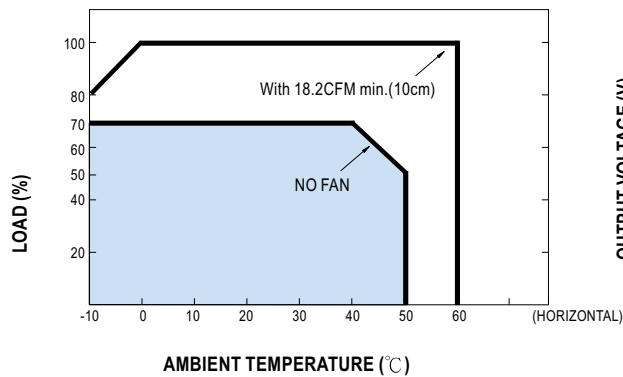

Static Characteristics (A)

