

## FEATURES

- Small footprint DC/DC converter, ideal for high current applications
- Tiny 0.9" x 1.3" x 0.40" open frame package
- Industry standard DOSA "brick" format and pinout
- 36-75 Volts DC input range
- 2250 Volt Basic input/output isolation (48V models)
- Up to 66 Watts total output power with overtemperature shutdown
- High efficiency synchronous rectifier forward topology
- Stable no-load operation with no required external components
- Operating temperature range -40 to +85°C with derating
- UL 60950-1, CSA-C22.2 No. 234, EN60950-1 safety approvals (pending)
- Extensive self-protection shut down features

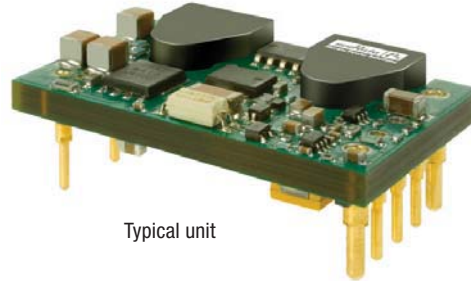

Typical unit

## PRODUCT OVERVIEW

The world of "brick" DC/DC converters has seen a steady size reduction. The ULS series makes another dramatic size shrink down to a "sixteenth-brick" width (0.9 inches) while still retaining a 66 Watt output and full 2250 Volt DC isolation. The PC-board mount converter family accepts 36 to 75 Volts DC inputs and delivers fixed outputs regulated to within  $\pm 0.2\%$ . The ULS converters are ideal for datacom and telecom applications, cell phone towers, data centers, server farms and network repeaters.

ULS outputs may be trimmed within  $\pm 10\%$  of nominal output while delivering fast settling to current step loads and no adverse effects from higher capacitive loads. Excellent ripple and noise specifications assure compatibility to circuits using CPU's, ASIC's, programmable logic and FPGA's. No

minimum load is required. For systems requiring controlled startup/shutdown, an external remote On/Off control may use a switch, transistor or digital logic. Remote Sense inputs compensate for resistive line drops at high currents.

Many self-protection features on the ULS series avoid both converter and external circuit hazards. These include input undervoltage lockout and overtemperature shutdown. The outputs current limit using the "hiccup" autorestart technique and the outputs may be short-circuited indefinitely. Additional features include output overvoltage and reverse conduction elimination.

The synchronous rectifier forward topology yields high efficiency for minimal heat buildup and "no fan" operation.

## SIMPLIFIED BLOCK DIAGRAM

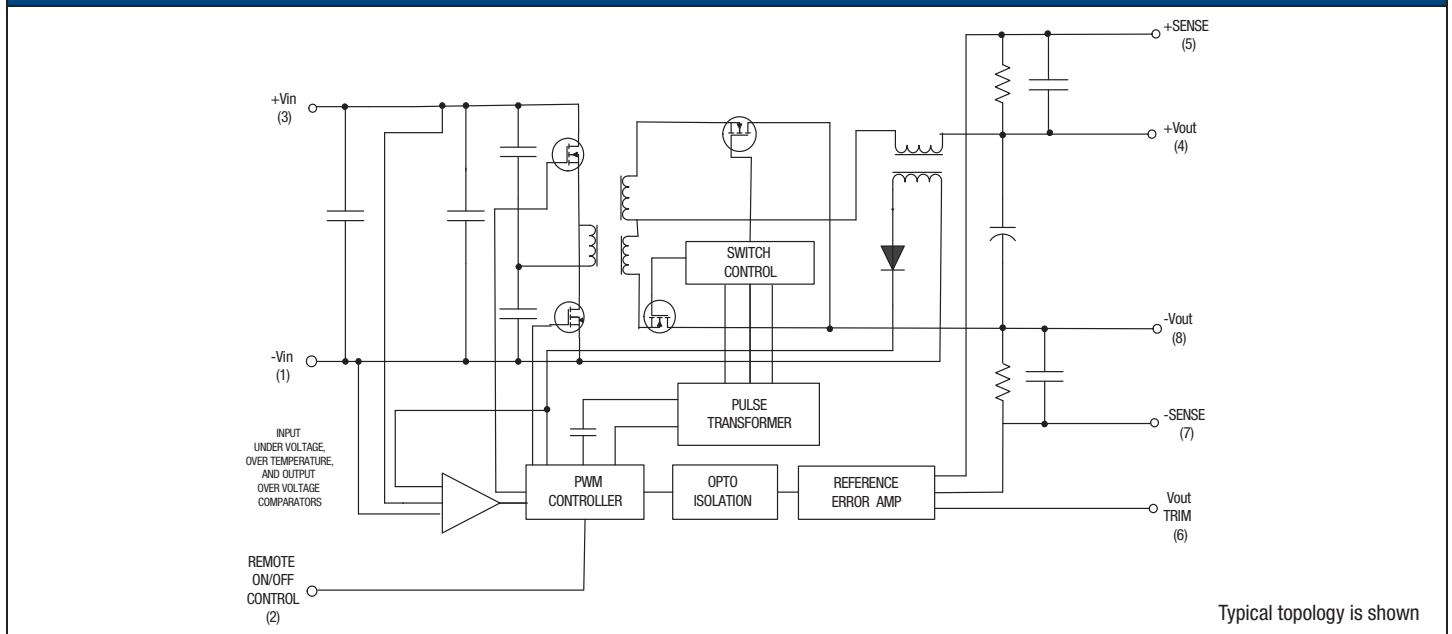

Figure 1. Simplified Block Diagram



PERFORMANCE SPECIFICATIONS AND ORDERING GUIDE ①														
Root Model ①	Output						Input				Efficiency		C76 Package	
	V <sub>OUT</sub> (V)	I <sub>OUT</sub> (A, max.)	Power (W)	R/N (mV pk-pk) ②		Regulation (max.) ④		V <sub>IN</sub> Nom. (V)	Range (V)	I <sub>IN</sub> , no load (mA)	I <sub>IN</sub> , full load (A)	Min.	Typ.	Case (inches)
				Typ.	Max.	Line	Load							
ULS-3.3/20-D48N-C	3.3	20	66	70	120	±0.1%	±0.2%	48	36-75	20	1.53	89%	90%	0.9x1.3x0.40
ULS-5/12-D48N-C	5	12	60	50	80	±0.125%	±0.25%	48	36-75	40	1.39	88%	90%	0.9x1.3x0.40
ULS-12/5-D48N-C	12	5	60	80	120	±0.125%	±0.25%	48	36-75	50	1.37	88%	91%	0.9x1.3x0.40
ULS-15/2-D48N-C	15	2	PRELIMINARY – Please contact Murata Power Solutions for further information.										0.9x1.3x0.40	
ULS-12/2.5-D48N-C	12	2.5											0.9x1.3x0.40	

- ① Please refer to the Part Number Structure when ordering.
- ② These specifications are preliminary. Contact Murata Power Solutions for availability.
- ③ All specifications are at nominal line voltage and full load, +25°C unless otherwise noted. See detailed specifications. Output capacitors are 1 µF ceramic multilayer in parallel with 10 µF electrolytic. I/O caps are necessary for our test equipment and may not be needed for your application.
- ④ Regulation specifications describe output voltage deviations from a nominal/midpoint value to either extreme (50% load step).
- ⑤ Models ULS-12/2.5-D48N-C and ULS-15/2-D48N-C do not include sense pins.

### PART NUMBER STRUCTURE

**ULS - 3.3 / 20 - D48 N H Lx - C**

- Sixteenth Brick Series**
- Nominal Output Voltage:** 3.3V, 5V, 12V, 15V
- Maximum Rated Output Current:** 20A, 12A, 5A, 2A  
Current in Amps
- Input Voltage Range:** D48 = 36-75 Volts (48V nominal)
- RoHS Hazardous Substance Compliance**  
(does not claim EU RoHS exemption 7b-lead in solder)  
C = RoHS-6  
Y = RoHS-5
- Pin Length Option (Thru-hole only)**  
Blank = Standard pin length 0.180" (4.6mm)  
L1 = 0.110" (2.79mm)  
L2 = 0.145" (3.68mm)
- Conformal Coating:**  
Blank = No coating, standard  
H = Coating added, optional special order
- On/Off Control Polarity:**  
N = Negative, standard  
P = Positive, optional special order

**Note:** Some model number combinations may not be available. Contact Murata Power Solutions.

### On/Off Enable Control Ground Bounce Protection

To improve reliability, if you use a small signal transistor or other external circuit to select the Remote On/Off control, make sure to return the LO side directly to the -Vin power input on the DC/DC converter. To avoid ground bounce errors, do not connect the On/Off return to a distant ground plane or current-carrying bus. If necessary, run a separate small return wire directly to the -Vin terminal. There is very little current (typically 1-5 mA) on the On/Off control however, large current changes on a return ground plane or ground bus can accidentally trigger the converter on or off. If possible, mount the On/Off transistor or other control circuit adjacent to the converter.

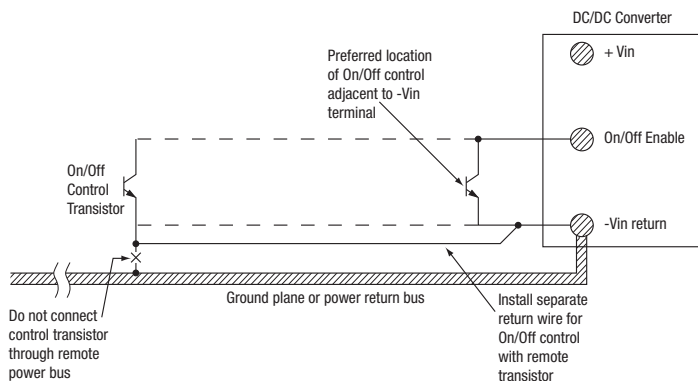
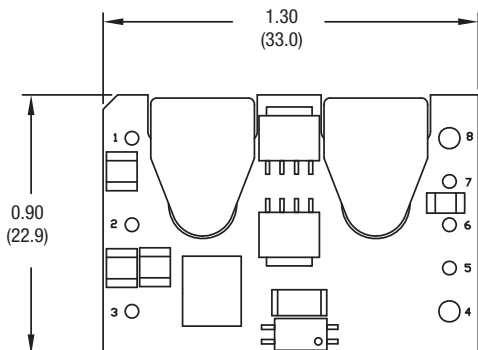

Figure 2. On/Off Enable Control Ground Bounce Protection

## MECHANICAL SPECIFICATIONS

### Case C76



Top View

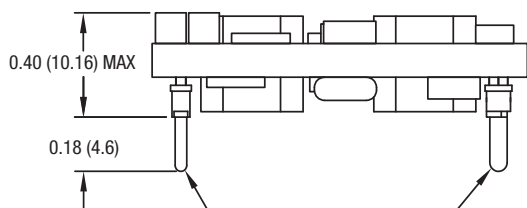

Side View

Ø0.040±0.002 Pin with  
Ø0.062±0.002 Shoulder  
6x at Pins 1, 2, 3, 5, 6 & 7

Ø0.06±0.002 Pin with  
Ø0.083±0.002 Shoulder  
2x at Pins 4 & 8

### Bottom View from Pin Side

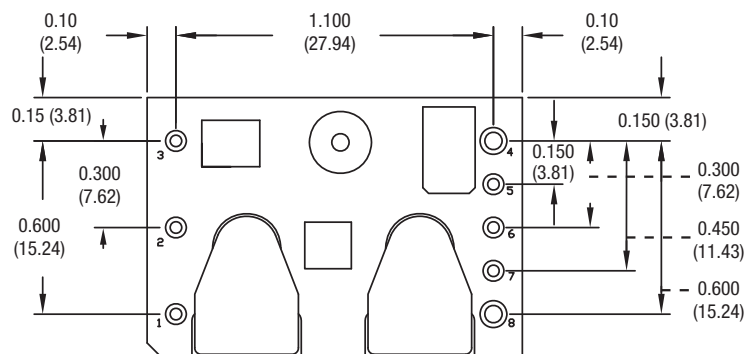

Pin material: Copper alloy. Plating: Gold over nickel

### INPUT/OUTPUT CONNECTIONS P75

Pin	Function	Pin	Function
3	Negative Input	4	Negative Output
		5	-Sense In*
2	On/Off Control	6	Trim
		7	+Sense In*
1	Positive Input	8	Positive Output

Important! **Always** connect the sense pins. If they are not connected to a remote load, wire each sense pin to its respective voltage output at the converter pins.

\* Models ULS-12/2.5-D48N-C and ULS-15/2-D48N-C do not include sense pins.

The 0.18-inch pin length is shown. Please refer to the part number structure for alternate pin lengths.

Dimensions are in inches (mm) shown for ref. only.

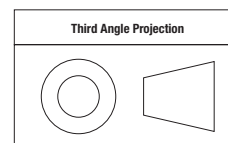

Tolerances (unless otherwise specified):  
.XX ± 0.02 (0.5)  
.XXX ± 0.010 (0.25)  
Angles ± 2°

Components are shown for reference only.

### Performance/Functional Specifications

Typical at  $T_A = +25^\circ\text{C}$  under nominal line voltage, nominal output voltage, natural air convection, 1  $\mu\text{F}$  || 10  $\mu\text{F}$  output external caps, 22 $\mu\text{F}$  low ESR input external cap and full-load conditions unless otherwise noted.<sup>(1)</sup>

Input	
<b>Input Voltage Range</b>	See Ordering Guide
<b>Start-up Threshold</b>	34.5 Volts
<b>Undervoltage Shutdown</b> <sup>(12)</sup>	32.5 Volts
<b>Overvoltage Shutdown</b>	None
<b>Reflected (Back) Ripple Current</b> <sup>(2)</sup>	20 mA pk-pk
<b>Input Current</b>	
Full Load Conditions	See Ordering Guide
Inrush Transient	0.05 A <sup>2</sup> Sec.
Output Short Circuit Current	100 mA
Low Line ( $V_{in} = V_{min.}$ )	2.08 Amps (ULS-3.3/20-D48) 1.85 Amps (ULS-5/12-D48) 1.83 Amps (ULS-12/5-D48)
Standby Mode (Off, UV, OT shutdown)	5 mA
<b>Internal Input Filter Type</b>	Capacitive
<b>Recommended External Fast Blow Fuse</b>	10 Amps
<b>Reverse Polarity Protection</b>	None, install external fuse
<b>Remote On/Off Control</b> <sup>(6)</sup>	
Positive Logic ("P" model suffix)	Off = ground pin to +1.0 V Max On = open pin or + 3.5 V min. to +15 V Max
Negative Logic ("N" model suffix)	Off = open pin or +2.5 V min. to +15 V Max On = -0.1 V to +0.8 V Max
Current, mA	1-5
Output	
<b>Voltage Output Range</b> <sup>(3)(15)</sup>	See Ordering Guide
<b>Voltage Output Accuracy</b>	$\pm 1\%$ of $V_{nominal}$
<b>Adjustment Range</b> <sup>(6)</sup>	-10% to +10% of $V_{nominal}$
<b>Temperature Coefficient</b>	$\pm 0.02\%$ of $V_{out}$ range per $^\circ\text{C}$
<b>Minimum Loading</b>	No minimum load
<b>Remote Sense Compensation</b>	10% max. of $V_{set}$ <sup>(18)</sup>
<b>Ripple/Noise</b> (20 MHz bandwidth)	See Ordering Guide <sup>(9)(14)</sup>
<b>Line/Load Regulation</b> <sup>(7)</sup>	See Ordering Guide
<b>Efficiency</b>	See Ordering Guide
<b>Maximum Capacitive Loading</b>	1000 $\mu\text{F}$ max. (Low ESR > 0.02 $\Omega$ min., resistive load)
<b>Isolation Voltage</b>	
Input to Output	2250 Vdc min.
<b>Isolation Resistance</b>	10 Megohms min.
<b>Isolation Capacitance</b>	1000 pF
<b>Isolation Safety Rating</b>	Basic insulation
<b>Current Limit Inception</b> <sup>(13)</sup>	26 Amps (ULS-3.3/20-D48, ULS-5/12-D48) 6.8 Amps (ULS-12/5-D48)
<b>Short Circuit</b> <sup>(5)</sup>	
Protection Method	Current limiting with hiccup autorestart. Remove overload for recovery.
Short Circuit Current	6.6 Amps (ULS-3.3/20-D48) 0.5 Amps (ULS-5/12-D48) 0.6 Amps (ULS-12/5-D48)
Short Circuit Duration	Continuous, output shorted to ground (no damage)

### Output, continued

<b>Overvoltage Protection</b> via Magnetic feedback	4.29 Volts (ULS-3.3/20-D48) 6.5 Volts (ULS-5/12-D48) 14.5 Volts (ULS-12/5-D48)
<b>Dynamic Load Response</b>  (50-75% load step)	150 $\mu\text{Sec}$ to $\pm 1\%$ of final value (ULS-3.3/20-D48) 25-50-25 $\mu\text{Sec}$ to $\pm 1\%$ of final value (ULS-5/12-D48, ULS-12/5-D48)
<b>Start-Up Time</b>	5 mSec (ULS-3.3/20-D48) 10 mSec (ULS-5/12-D48) $V_{in}$ on to $V_{out}$ regulated 30 mSec (ULS-12/5-D48) Remote On/Off to $V_{out}$ regulated 30 mSec (ULS-12/5-D48)
<b>Switching Frequency</b>	400-520 kHz
<b>Pre-Bias Load Startup</b>	The converter will start if the external load pre-bias does not exceed $V_{nominal}$

### Environmental

<b>Calculated MTBF</b> <sup>(4)</sup>	3.2M Hours
<b>Operating Temperature Range</b>	$-40$ to $+85^\circ\text{C}$ <sup>(11)</sup> With derating See Derating Curves
<b>Storage Temperature Range</b>	$-55$ to $+125^\circ\text{C}$
<b>Thermal Protection/Shutdown</b>	$+110$ - $125^\circ\text{C}$ (hot spot)
<b>Relative Humidity (non-condensing)</b>	to $+85\%RH/+85^\circ\text{C}$

### Physical

<b>Outline Dimensions</b>	See Mechanical Specifications
<b>Pin Material</b>	Gold-plated copper alloy with nickel underplate
<b>Pin Diameter</b>	
(Pins 1-3,5-7)	0.04" (1.02mm)
(Pins 4 & 8)	0.062" (1.52mm)
<b>Weight</b>	0.58 ounce (16.4 grams)
<b>Electromagnetic Interference</b>	EN55022/CISPR22 (requires external filter)
<b>Safety (designed to meet)</b>	UL/cUL 60950-1 CSA-C22.2 No.234 IEC/EN 60950-1
<b>Flammability Rating</b>	UL94V-0 (designed to meet)

### Absolute Maximum Ratings

<b>Input Voltage</b>	
Continuous	+75 Volts
Transient (100 mS)	+100 Volts
<b>On/Off Control</b>	0 V. min to +15 V. max.
<b>Input Reverse Polarity Protection</b>	None, install external fuse
<b>Output Current</b>	Current-limited. Devices can withstand sustained short circuit without damage.
<b>Storage Temperature</b>	$-55$ to $+125^\circ\text{C}$
<b>Lead Temperature</b>	See soldering guidelines

Absolute maximums are stress ratings. Exposure of devices to greater than any of these conditions may adversely affect long-term reliability. Proper operation under conditions other than those listed in the Performance/Functional Specifications Table is not implied or recommended.

### Performance Specification Notes

- All specifications are typical unless noted. Ambient temperature = +25°Celsius,  $V_{IN}$  is nominal, output current is maximum rated nominal. External output capacitance is 1  $\mu$ F multilayer ceramic paralleled with 10  $\mu$ F electrolytic. All caps are low ESR. These capacitors are necessary for our test equipment and may not be needed in your application. Testing must be kept short enough that the converter does not appreciably heat up during testing. For extended testing, use plenty of airflow. See Derating Curves for temperature performance. All models are stable and regulate within spec without external capacitance.
- Input Ripple Current is tested and specified over a 5-20 MHz bandwidth and uses a special set of external filters only for the Ripple Current specifications. Input filtering is  $C_{IN} = 33 \mu F$ ,  $C_{BUS} = 220 \mu F$ ,  $L_{BUS} = 12 \mu H$ . Use capacitor rated voltages which are twice the maximum expected voltage. Capacitors must accept high speed AC switching currents.
- Note that Maximum Current Derating Curves indicate an average current at nominal input voltage. At higher temperatures and/or lower airflow, the converter will tolerate brief full current outputs if the average RMS current over time does not exceed the Derating curve. All Derating curves are presented at sea level altitude. Be aware of reduced power dissipation with increasing density altitude.
- Mean Time Before Failure (MTBF) is calculated using the Telcordia (Belcore) SR-332 Method 1, Case 3, Issue 1, ground fixed conditions. Operating temperature = +30°C, full output load, natural air convection.
- The output may be shorted to ground indefinitely with no damage. The Output Short Circuit Current shown in the specifications is an average consisting of very short bursts of full rated current to test whether the output circuit can be repowered.
- The On/Off Control is normally driven from a switch or relay. An open collector/open drain transistor may be used in saturation and cut-off (pinch-off) modes. External logic may also be used if voltage levels are fully compliant to the specifications.
- Regulation specifications describe the deviation as the input line voltage or output load current is varied from a nominal midpoint value to either extreme (50% load).
- Do not exceed maximum power ratings, Sense limits or output overvoltage when adjusting output trim values.
- At zero output current,  $V_{out}$  may contain components which slightly exceed the ripple and noise specifications.
- Output overload protection is non-latching. When the output overload is removed, the output will automatically recover.
- All models are fully operational and meet published specifications, including "cold start" at -40°C.
- The converter will shut off if the input falls below the undervoltage threshold. It will not restart until the input exceeds the Input Start Up Voltage.
- Short circuit shutdown begins when the output voltage degrades approximately 2% from the selected setting.
- Output noise may be further reduced by installing an external filter. See the Application Notes. Use only as much output filtering as needed *and no more*. Larger caps (especially low-ESR ceramic types) may slow transient response or degrade dynamic performance. Thoroughly test your application with all components installed.
- To avoid damage or unplanned shutdown, do not sink appreciable reverse output current.
- If reverse polarity is accidentally applied to the input, to ensure reverse input protection with full output load, always connect an external fast blow input fuse in series with the + $V_{IN}$  input.
- Although extremely unlikely, failure of the internal components of this product may expose external application circuits to dangerous voltages, currents, temperatures or power levels. Please thoroughly verify all applications before committing them to service. Be sure to include appropriately-rated FUSES (see specifications and Application Notes) to reduce the risk of failure.
- Models ULS-12/2.5-D48 and ULS-15/2-D48 do not include sense pins.

### Soldering Guidelines

Murata Power Solutions recommends the specifications below when installing these converters. These specifications vary depending on the solder type. Exceeding these specifications may cause damage to the product. Your production environment may differ; therefore please thoroughly review these guidelines with your process engineers.

Wave Solder Operations for through-hole mounted products (THMT)			
For Sn/Ag/Cu based solders:		For Sn/Pb based solders:	
Maximum Preheat Temperature	115° C.	Maximum Preheat Temperature	105° C.
Maximum Pot Temperature	270° C.	Maximum Pot Temperature	250° C.
Maximum Solder Dwell Time	7 seconds	Maximum Solder Dwell Time	6 seconds

**Input Fusing**

Certain applications and/or safety agencies may require the installation of fuses at the inputs of power conversion components. Fuses should also be used if the possibility of sustained, non-current-limited, input-voltage polarity reversals exists. For DATEL ULS series DC/DC converters, we recommend the use of a fast blow fuse, installed in the ungrounded input supply line with a typical value about twice the maximum input current, calculated at low line with the converter's minimum efficiency.

All relevant national and international safety standards and regulations must be observed by the installer. For system safety agency approvals, the converters must be installed in compliance with the requirements of the end-use safety standard, i.e. IEC/EN/UL60950-1.

**Input Reverse-Polarity Protection**

If the input voltage polarity is accidentally reversed, an internal diode will become forward biased and likely draw excessive current from the power source. If this source is not current limited or the circuit appropriately fused, it could cause permanent damage to the converter.

**Input Under-Voltage Shutdown and Start-Up Threshold**

Under normal start-up conditions, devices will not begin to regulate properly until the ramping-up input voltage exceeds the Start-Up Threshold Voltage. Once operating, devices will not turn off until the input voltage drops below the Under-Voltage Shutdown limit. Subsequent re-start will not occur until the input is brought back up to the Start-Up Threshold. This built in hysteresis prevents any unstable on/off situations from occurring at a single input voltage.

**Start-Up Time**

The  $V_{IN}$  to  $V_{OUT}$  Start-Up Time is the time interval between the point at which the ramping input voltage crosses the Start-Up Threshold and the fully loaded output voltage enters and remains within its specified accuracy band. Actual measured times will vary with input source impedance, external input capacitance, and the slew rate and final value of the input voltage as it appears at the converter. The ULS Series implements a soft start circuit to limit the duty cycle of its PWM controller at power up, thereby limiting the input inrush current.

The On/Off Control to  $V_{OUT}$  start-up time assumes the converter has its nominal input voltage applied but is turned off via the On/Off Control pin. The specification defines the interval between the point at which the converter is turned on (released) and the fully loaded output voltage enters and remains within its specified accuracy band. Similar to the  $V_{IN}$  to  $V_{OUT}$  start-up, the On/Off Control to  $V_{OUT}$  start-up time is also governed by the internal soft start circuitry and external load capacitance. The difference in start up time from  $V_{IN}$  to  $V_{OUT}$  and from On/Off Control to  $V_{OUT}$  is therefore insignificant.

**Input Source Impedance**

The input of ULS converters must be driven from a low ac-impedance source. The DC/DC's performance and stability can be compromised by the use of highly inductive source impedances. The input circuit shown in Figure 3 is a practical solution that can be used to minimize the effects of inductance in the input traces. For optimum performance, components should be mounted close to the DC/DC converter.

**I/O Filtering, Input Ripple Current, and Output Noise**

All models in the ULS Series are tested/specified for input reflected ripple current and output noise using the specified external input/output components/circuits and layout as shown in the following two figures. External input capacitors ( $C_{IN}$  in Figure 3) serve primarily as energy-storage elements, minimizing line voltage variations caused by transient IR drops in conductors from backplane to the DC/DC. Input caps should be selected for bulk capacitance (at appropriate frequencies), low ESR, and high rms-ripple-current ratings. The switching nature of DC/DC converters requires that dc voltage sources have low ac impedance as highly inductive source impedance can affect system stability. In Figure 3,  $C_{BUS}$  and  $L_{BUS}$  simulate a typical dc voltage bus. Your specific system configuration may necessitate additional considerations.

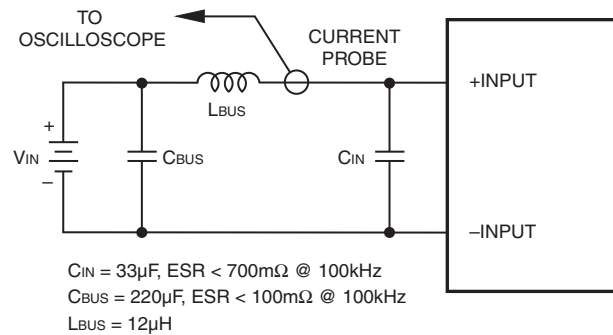

Figure 3. Measuring Input Ripple Current

In critical applications, output ripple/noise (also referred to as periodic and random deviations or PARD) may be reduced below specified limits using filtering techniques, the simplest of which is the installation of additional external output capacitors. They function as true filter elements and should be selected for bulk capacitance, low ESR and appropriate frequency response.

All external capacitors should have appropriate voltage ratings and be located as close to the converter as possible. Temperature variations for all relevant parameters should also be taken carefully into consideration. The most effective combination of external I/O capacitors will be a function of line voltage and source impedance, as well as particular load and layout conditions.

In Figure 4, the two copper strips simulate real-world PCB impedances between the power supply and its load. In order to minimize measurement errors, scope measurements should be made using BNC connectors, or the probe ground should be less than 1/2 inch and soldered directly to the fixture.

**Floating Outputs**

Since these are isolated DC/DC converters, their outputs are "floating" with respect to their input. Designers will normally use the -Output as the ground/return of the load circuit. You can however, use the +Output as ground/return to effectively reverse the output polarity.

**Minimum Output Loading Requirements**

ULS converters employ a synchronous-rectifier design topology and all models regulate within spec and are stable under no-load to full load conditions. Operation under no-load conditions however might slightly increase the output ripple and noise.

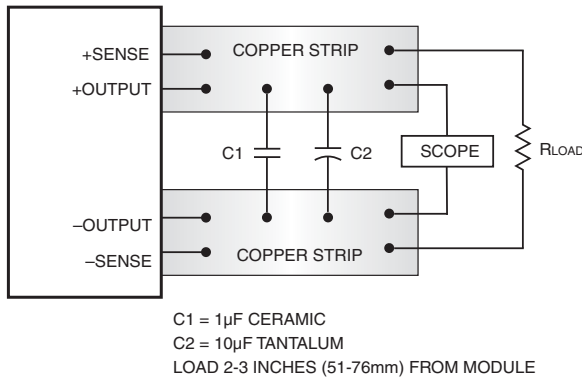

**Figure 4. Measuring Output Ripple/Noise (PARD)**

**Thermal Shutdown**

The ULS converters are equipped with thermal-shutdown circuitry. If environmental conditions cause the temperature of the DC/DC converter to rise above the designed operating temperature, a precision temperature sensor will power down the unit. When the internal temperature decreases below the threshold of the temperature sensor, the unit will self start. See Performance/Functional Specifications.

**Output Over-Voltage Protection**

The ULS output voltage is monitored for an over-voltage condition using a comparator. The signal is optically coupled to the primary side and if the output voltage rises to a level which could be damaging to the load, the sensing circuitry will power down the PWM controller causing the output voltage to decrease. Following a time-out period the PWM will restart, causing the output voltage to ramp to its appropriate value. If the fault condition persists, and the output voltage again climbs to excessive levels, the over-voltage circuitry will initiate another shutdown cycle. This on/off cycling is referred to as “hiccup” mode.

**Current Limiting**

As soon as the output current increases to approximately 130% of its rated value, the DC/DC converter will go into a current-limiting mode. In this condition, the output voltage will decrease proportionately with increases in output current, thereby maintaining somewhat constant power dissipation. This is commonly referred to as power limiting. Current limit inception is defined as the point at which the full-power output voltage falls below the specified tolerance. See Performance/Functional Specifications. If the load current, being drawn from the converter, is significant enough, the unit will go into a short circuit condition as described below.

**Short Circuit Condition**

When a converter is in current-limit mode, the output voltage will drop as the output current demand increases. If the output voltage drops too low, the magnetically coupled voltage used to develop primary side voltages will also drop, thereby shutting down the PWM controller. Following a time-out period, the PWM will restart causing the output voltage to begin ramping to their appropriate value. If the short-circuit condition persists, another shutdown cycle will be initiated. This on/off cycling is referred to as “hiccup” mode. The hiccup cycling reduces the average output current, thereby preventing internal temperatures from rising to excessive levels. The ULS Series is capable of enduring an indefinite short circuit output condition.

**Remote Sense**

**Note:** The Sense and V<sub>OUT</sub> lines are internally connected through low-value resistors. Nevertheless, if the sense function is not used for remote regulation the user should connect the +Sense to +V<sub>OUT</sub> and –Sense to –V<sub>OUT</sub> at the DC/DC converter pins. ULS series converters employ a sense feature to provide point of use regulation, thereby overcoming moderate IR drops in PCB conductors or cabling. The remote sense lines carry very little current and therefore require minimal cross-sectional-area conductors. The sense lines, which are capacitively coupled to their respective output lines, are used by the feedback control-loop to regulate the output. As such, they are not low impedance points and must be treated with care in layouts and cabling. Sense lines on a PCB should be run adjacent to dc signals, preferably ground.

$$[V_{OUT(+)} - V_{OUT(-)}] - [Sense(+)-Sense(-)] \leq 10\%V_{OUT}$$

In cables and discrete wiring applications, twisted pair or other techniques should be used. Output over-voltage protection is monitored at the output voltage pin, not the Sense pin. Therefore, excessive voltage differences between V<sub>OUT</sub> and Sense in conjunction with trim adjustment of the output voltage can cause the over-voltage protection circuitry to activate (see Performance Specifications for over-voltage limits). Power derating is based on maximum output current and voltage at the converter’s output pins. Use of trim and sense functions can cause output voltages to increase, thereby increasing output power beyond the converter’s specified rating, or cause output voltages to climb into the output over-voltage region. Therefore, the designer must ensure:

$$(V_{OUT \text{ at pins}}) \times (I_{OUT}) \leq \text{rated output power}$$

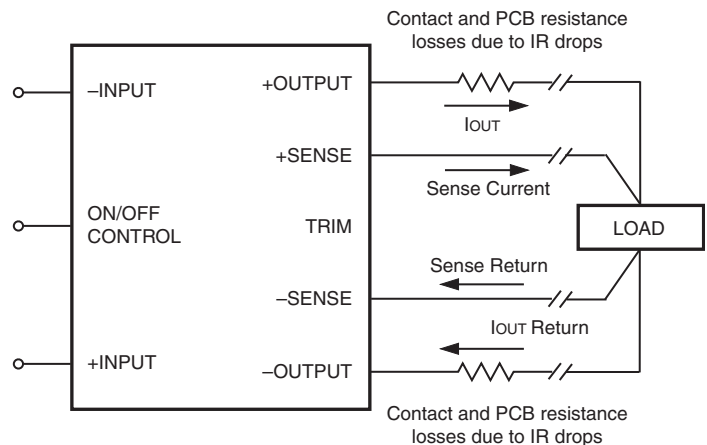

**Figure 5. Remote Sense Circuit Configuration**

**On/Off Control**

The input-side, remote On/Off Control function can be ordered to operate with either polarity:

**Positive** (“P” suffix) polarity models are enabled when the on/off pin is left open (or is pulled high, applying +3.5V to +13.5V with respect to –Input) as per Figure 6. Positive-polarity devices are disabled when the on/off pin is pulled low (0 to 0.8V with respect to –Input).

**Negative** (“N” suffix) polarity devices are off when pin is left open (or pulled high, applying +3.5V to +13.5V), and on when pin is pulled low (0 to 1V) with respect to –Input as shown in Figure 10.

Dynamic control of the remote on/off function is best accomplished with a mechanical relay or an open-collector/open-drain drive circuit (optically isolated if appropriate). The drive circuit should be able to sink appropriate current (see Performance Specifications) when activated and withstand appropriate voltage when deactivated. Applying an external voltage to pin 2 when no input power is applied to the converter can cause permanent damage to the converter.

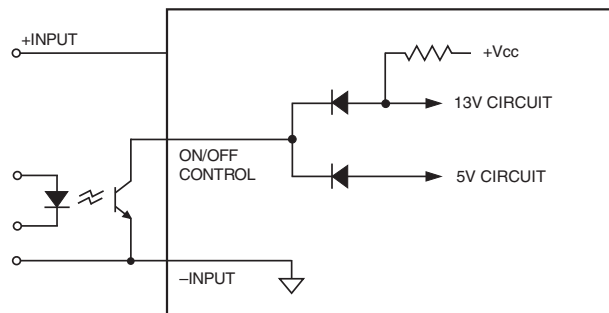

Figure 6. Driving the Negative Polarity On/Off Control Pin (simplified circuit)

**OUTPUT VOLTAGE ADJUSTMENT**

**Trim Equations**

**Trim Down**

$$R_{T\_DOWN} (k\Omega) = \frac{5.11}{\Delta} - 10.22$$

Where  $\Delta = \left| \frac{V_{OUT} - V_{NOM}}{V_{NOM}} \right|$

**Trim Up**

$$R_{T\_UP} (k\Omega) = \frac{5.11 \times V_{NOM} \times (1 + \Delta)}{1.225 \times \Delta} - \frac{5.11}{\Delta} - 10.22$$

Where  $\Delta = \left| \frac{V_{OUT} - V_{NOM}}{V_{NOM}} \right|$

**Note:** "Δ" is always a positive value.  
"V<sub>NOM</sub>" is the nominal, rated output voltage.  
"V<sub>OUT</sub>" is the desired, changed output voltage.

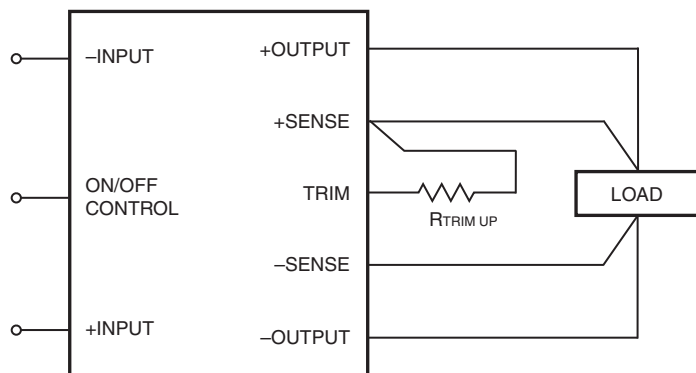

Figure 3. Trim Connections To Increase Output Voltages  
Connect sense to its respective V<sub>OUT</sub> pin if sense is not used with a remote load.

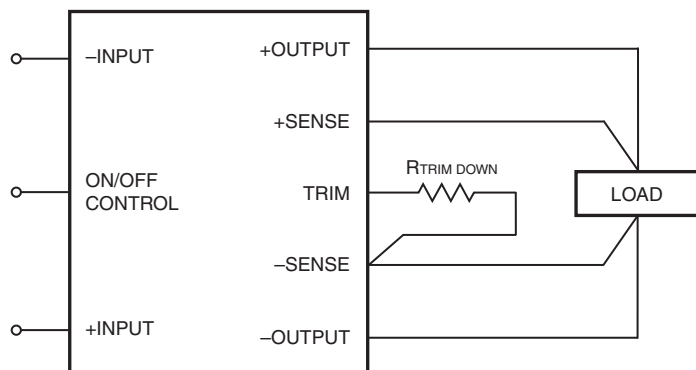
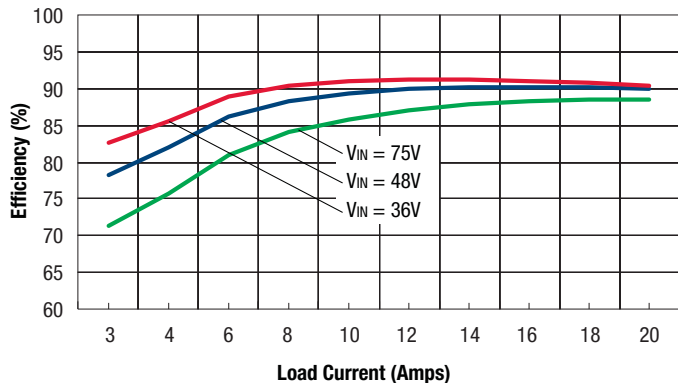

Figure 4. Trim Connections To Decrease Output Voltages



**TYPICAL PERFORMANCE CURVES, ULS-3.3-20-D48**

Efficiency vs. Line Voltage and Load Current @ 25°C



Maximum Current Temperature Derating at Sea Level  
(VIN = 48V, longitudinal airflow)

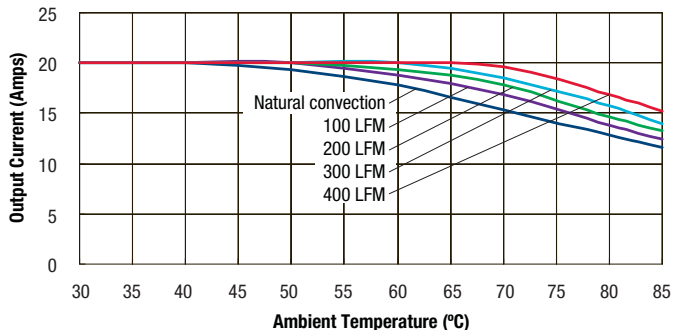

**TYPICAL PERFORMANCE CURVES, ULS-5/12-D48**

Efficiency and Power Dissipation @ 25°C

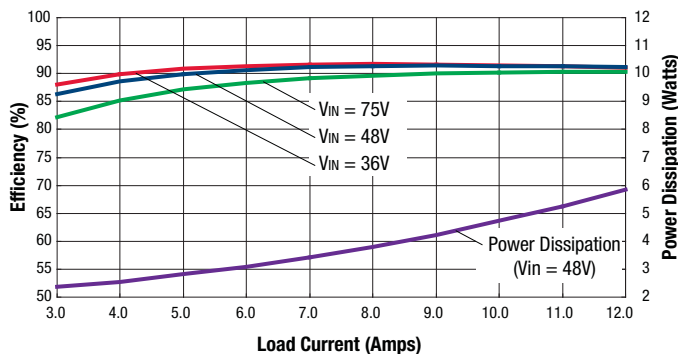

Maximum Current Temperature Derating at Sea Level  
(VIN = 48V, airflow is from Vin to Vout)

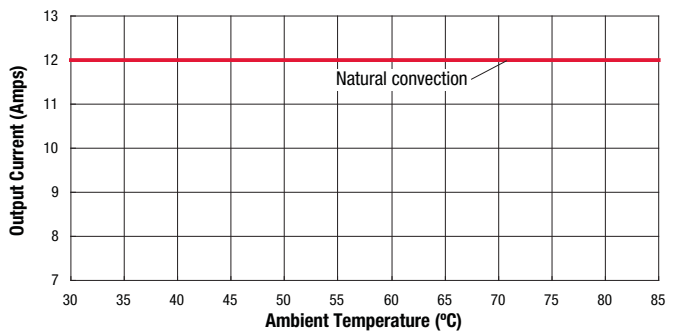

**TRANSIENT RESPONSE, ULS-3.3/20-D48**

(Resistive loads 50% with +25% step  $V_{in}=48V$ )

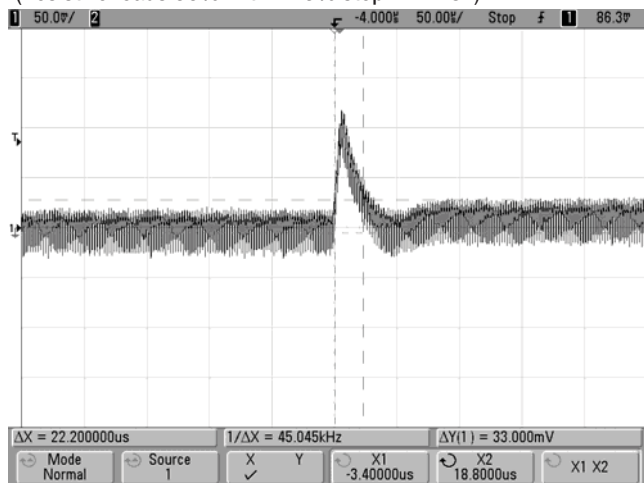

Transient Response (Load from 75% to 50%)

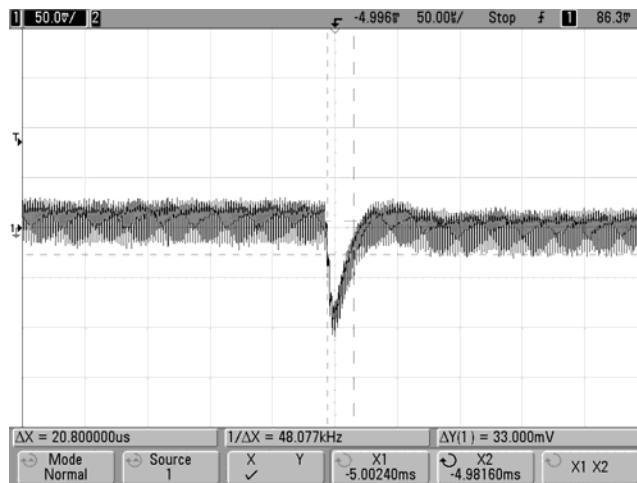

Transient Response (Load from 50% to 75%)

**Enable Start-up**

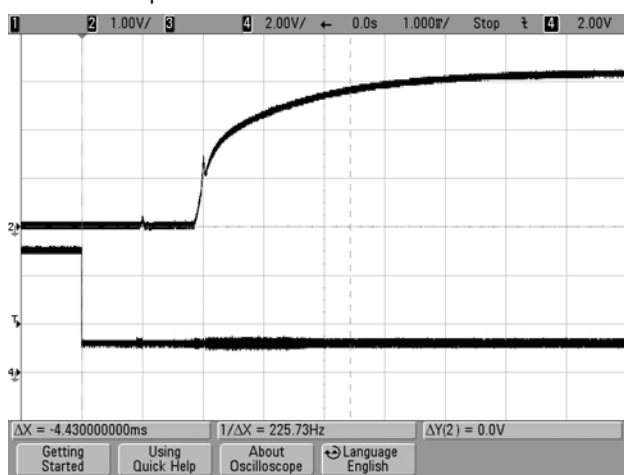

Enable Start-up ( $V_{in}=48V$   $I_{out}=20A$ )

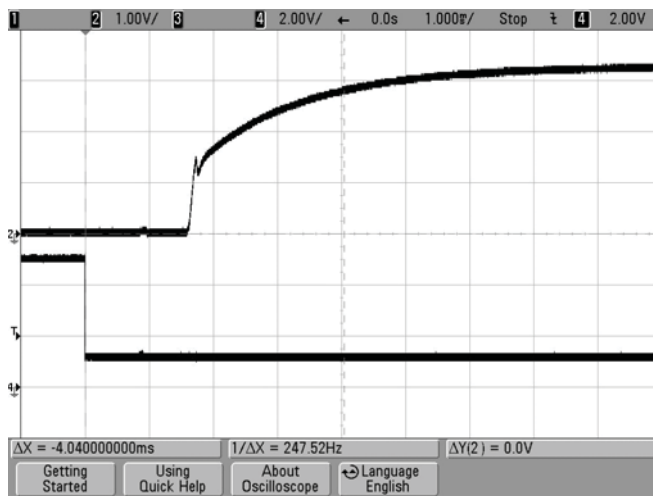

Enable Start-up ( $V_{in}=48V$   $I_{out}=0A$ )

**Ripple and Noise (1uF Ceramic and 10uF Tantalum Capacitors)**

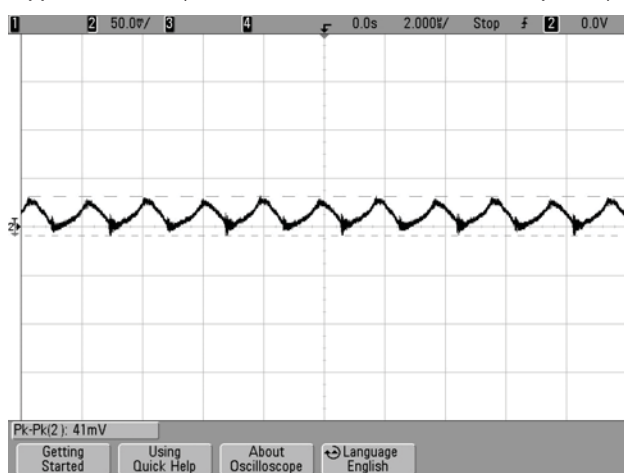

R/N Waveform ( $V_{in}=48V$   $I_{out}=20A$ )

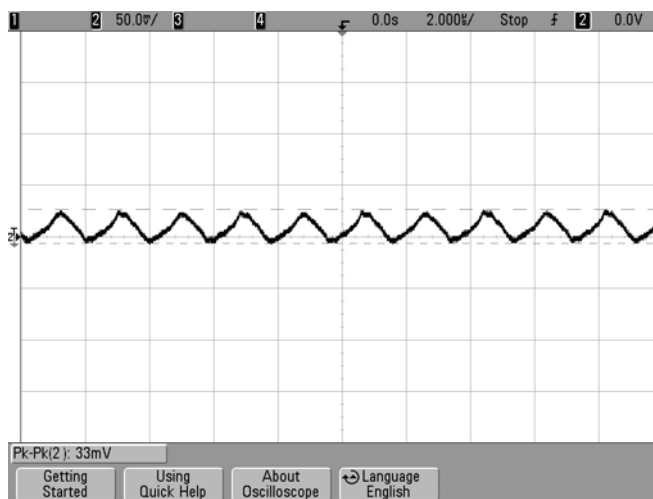

R/N Waveform ( $V_{in}=48V$   $I_{out}=0A$ )

## TYPICAL PERFORMANCE CURVES, ULS-12/5-D48

Efficiency and Power Dissipation vs. Line Voltage and Load Current @ 25°C

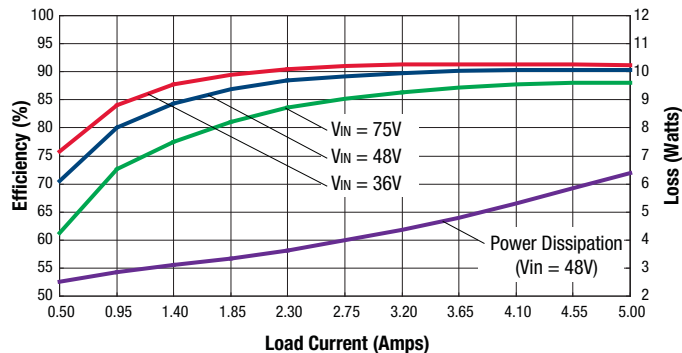

Maximum Current Temperature Derating at Sea Level  
( $V_{IN} = 48V$ , airflow is from  $V_{in}$  to  $V_{out}$ )

