

AN2108NFHQ

Camera Signal Processing(CDS + AGC + Gamma)

■ Overview

The AN2108NFHQ is a single-chip IC that processes video-signal of CCD-camera and has functions of CDS, AGC, pre-knee and pre-aperture circuits. This CDS circuit is capable of high speed sampling of max. 30 MHz to support high-resolution CCD-camera systems (XGA, SXGA, etc.). AGC and OB level(black level) adjustments can be controlled with on-chip 8-bit DAC.

■ Features

- Capable of high speed sampling of max. 30 MHz
- Capable of controlling OB level at the last output stage
- Capable of switching between 2 modes of pre-knee characteristic
- On-chip DAC(8-bit, 15-channel)for adjustment
(11-channels for internal and external outputs)

■ Applications

- Digital still cameras, Camcorders, PC cameras, Monitoring cameras, CCD camera modules, CCD digital camera systems

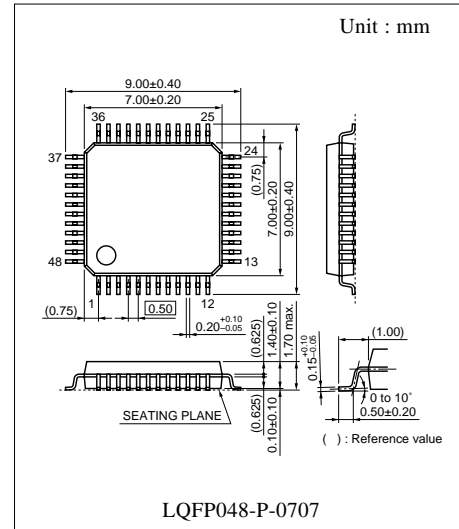

■ Block Diagram

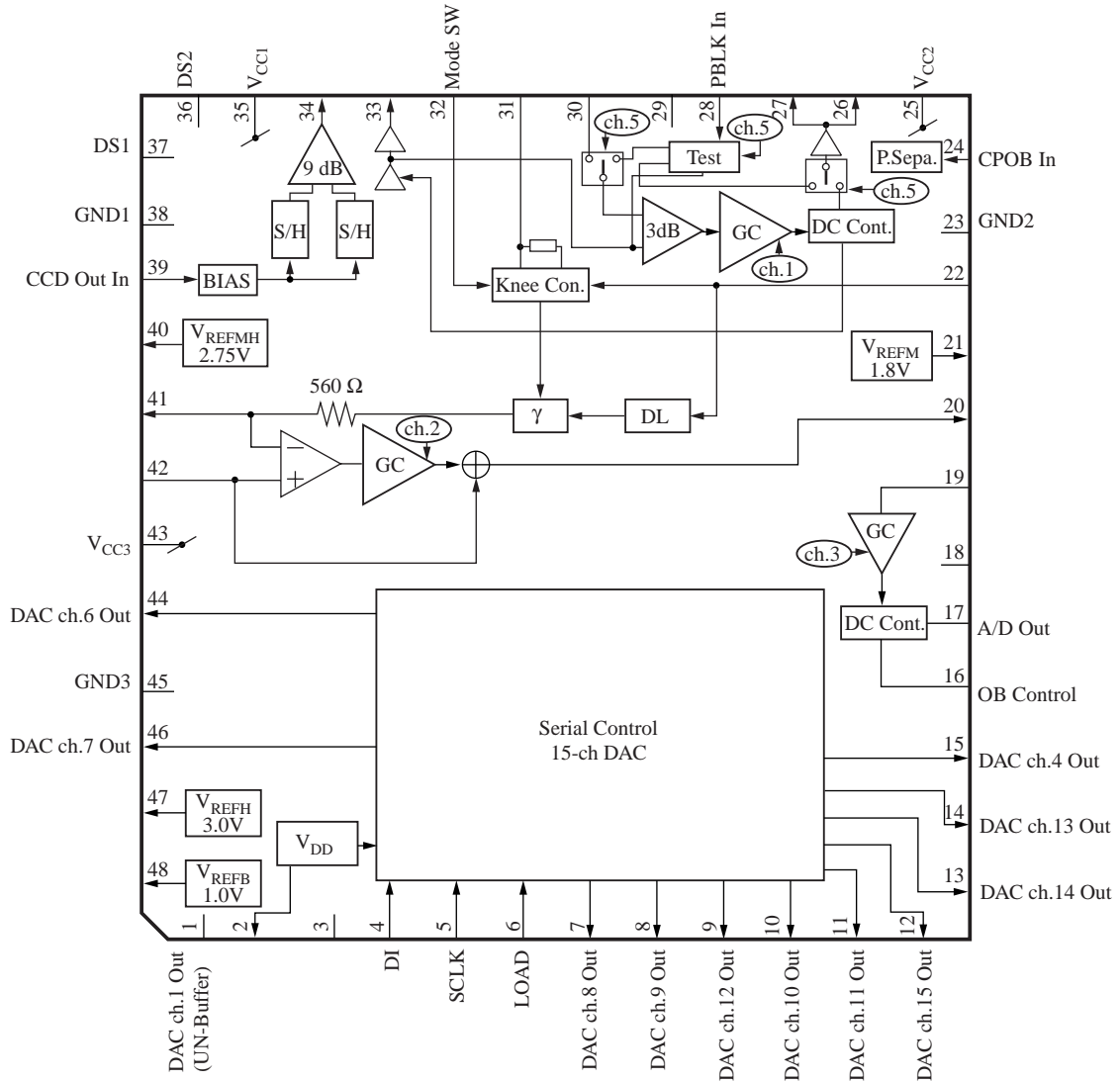

■ Pin Descriptions

Pin No.	Description	Pin No.	Description
1	DAC CH1 OUT(UN-Buffer)	25	V _{CC2}
2	V _{DD} OUT(3.5 V)	26	AGC OUT 1
3	V _{SS}	27	AGC OUT 2
4	DI	28	PBLK IN
5	SCLK	29	AGC DET
6	LOAD	30	AGC IN
7	DAC ch.8 OUT	31	Trap OUT
8	DAC ch.9 OUT	32	Gamma MODE SW
9	DAC ch.12 OUT	33	AGC REF OUT
10	DAC ch.10 OUT	34	CDS OUT
11	DAC ch.11 OUT	35	V _{CC2}
12	DAC ch.15 OUT	36	Sampling Puls DS2 IN
13	DAC ch.14 OUT	37	Sampling Puls DS1 IN
14	DAC ch.13 OUT	38	GND 1
15	DAC ch.4 OUT	39	CCD OUT IN
16	OB Control	40	V _{REFMH} OUT(2.7 V)
17	A/D OUT	41	Gamma OUT
18	Sub Amp. DET	42	Pre-aperture DL IN
19	Sub Amp. IN	43	V _{CC3}
20	Pre-aperture OUT	44	DAC ch.6 OUT
21	V _{REFM} OUT(1.8 V)	45	GND 3
22	Gamma IN	46	DAC ch.7 OUT
23	GND 2	47	V _{REFH} OUT(3.0 V)
24	CPOB IN	48	V _{REFB} OUT(1.0 V)

■ Absolute Maximum Ratings

Parameter	Symbol	Rating	Unit
Supply voltage	V_{CC}	5.5	V
Supply current	I_{CC}	—	mA
Power dissipation *2	P_D	226	mW
Operating ambient temperature *1	T_{opr}	-20 to +7.5	°C
Storage temperature *1	T_{stg}	-55 to +125	°C

Note) *1 : $T_a = 25$ °C, except storage temperature and operating ambient temperature.

*2 : The above power dissipation shows the package power dissipation at $T_a = 75$ °C, in free-air.

■ Recommended Operating Range

Parameter	Symbol	Range	Unit
Supply voltage	V_{CC}	4.5 to 5.1	V

■ Electrical Characteristics at $V_{CC} = 4.8$ V, $T_a = 25 \pm 2$ °C

Parameter	Symbol	Conditions	Min	Typ	Max	Unit
Circuit current	I_{TOT}	$V_{CC} = 4.8$ V	30	40	50	mA
Reference voltage 1	V_{REF1}	$V_{CC} = 4.8$ V	3.3	3.6	3.9	V
Reference voltage 2	V_{REF2}	$V_{CC} = 4.8$ V	2.9	3.0	3.1	V
Reference voltage 3	V_{REF3}	$V_{CC} = 4.8$ V	2.65	2.75	2.85	V
Reference voltage 4	V_{REF4}	$V_{CC} = 4.8$ V	1.7	1.8	1.9	V
Reference voltage 5	V_{REF5}	$V_{CC} = 4.8$ V	0.9	1.0	1.1	V
Pulse separation	CPOB	$V_{CC} = 4.8$ V	1.1	1.4	1.7	V
Sampling pulse threshold 1	V_{TH1}	$V_{CC} = 4.8$ V	1.15	1.45	1.75	V
Sampling pulse threshold 2	V_{TH2}	$V_{CC} = 4.8$ V	1.15	1.45	1.75	V
AGC frequency characteristic	G_{FA}	10 MHz Sine wave 300 mV _{PP}	-1.8	-0.4	1.0	dB
AGC level adjustment	V_{ADJ1}	10 stair step 300 mV _{PP}	46	60	7A	Hex
AGC output D-range	V_{AG3}	10 stair step 1.2 V _{PP}	1080	1200	1320	mV _{PP}
AGC min. gain	G_{AG4}	10 stair step 1.2 V _{PP}	—	-3	-5	dB
AGC max. gain	G_{AG5}	10 stair step 50 mV _{PP}	21	24	—	dB
Test signal adjustment	V_{TE}	PBLK input	C0	CE	DF	Hex
Gamma frequency characteristic	G_{FG}	10 MHz Sine wave 300 mV _{PP}	-2.2	-1.0	0.2	dB
Gamma characteristic 1	V_{GM1}	10 stair step 600 mV _{PP} 3rd stage Pin32 = GND	162	180	198	mV _{PP}
Gamma characteristic 2	V_{GM2}	10 stair step 600 mV _{PP} 6th stage Pin32 = GND	-1.0	0	1.0	dB
Gamma characteristic 3	V_{GM}	10 stair step 600 mV _{PP} 9th stage Pin32 = GND	30	80	130	mV _{PP}

■ Electrical Characteristics at $V_{CC} = 4.8 \text{ V}$, $T_a = 25 \pm 2 \text{ }^\circ\text{C}$ (Continued)

Parameter	Symbol	Conditions	Min	Typ	Max	Unit
Gamma characteristic 4	V_{GM4}	10 stair step 720 mV _{PP} Pin32 = GND	1.22	2.02	3.82	dB
Gamma characteristic 5	V_{GM6}	10 stair step 600 mV _{PP} 9th stage Pin32 = GND	10	30	50	mV _{PP}
Pre-aperture frequency characteristic	G_{FG}	10 MHz Sine wave 300 mV _{PP}	-1.6	-0.4	0.8	dB
Pre-aperture output D-range	V_{PR3}	10 stair step 800 mV _{PP}	700	800	900	mV _{PP}
Pre-aperture gain 1	V_{PR5}	9 MHz Sine wave 300 mV _{PP}	—	-0.2	0.5	dB
Pre-aperture gain 2	V_{PR4}	9 MHz Sine wave 300 mV _{PP}	5.0	7.0	—	dB
Output amplifier frequency characteristic	G_{FB}	10 MHz Sine wave 300 mV _{PP}	-1.6	-0.4	0.8	dB
Output amplifier level adjustment	V_{ADJ2}	10 stair step 300 mV _{PP}	7B	90	A5	Hex
Output amplifier output D-range	V_{AD5}	10 stair step 1000 mV _{PP}	2200	2450	2700	mV _{PP}
Output amplifier gain 1	G_{AD1}	10 stair step 300 mV _{PP}	—	2.5	4.0	dB
Output amplifier gain 2	G_{AD2}	10 stair step 300 mV _{PP}	13.5	15.5	—	dB
Output amplifier gain 3	G_{AD4}	10 stair step 600 mV _{PP}	-1.0	0	1.0	dB
A/D Out output DC 1	V_{OFF1}	Pin16 = 1.0 V	-70	0	70	mV
A/D Out output DC 2	V_{OFF2}	Pin16 = 1.4 V	-70	0	70	mV
Total frequency characteristic	G_{FT}		-3.5	-2.0	-0.5	dB
9 dB amplifier gain	G_1	Sampling pulse 10 MHz CDS input 300 mV _{PP}	7.6	8.6	9.6	dB

■ Electrical Characteristics(Continued)

• DAC serial Data Format

											Address Selection		Function					
D11	D10	D9	D8	D7	D6	D5	D4	D3	D2	D1	D0	Don't Care		Function				
0	0	0	0	0	0	0	0	0	0	0	0	Don't Care		—				
1	0	0	0	0	0	0	0	0	0	0	1	CH1		AGC gain control				
0	1	0	0	0	0	0	0	0	0	1	0	CH2		Pre-aperture gain control				
1	1	0	0	0	0	0	0	0	0	1	1	CH3		Sub amp. gain control				
0	0	1	0	·	·	·	·	·	·	·	·	CH4		Output DC control				
1	0	1	0	·	·	·	·	·	·	·	·	CH5		D7	D6	D5	D4—D0	
													AGC output pin signal switching		Pre-apa. On/Off		Test signal amplitude control	
0	1	1	0	·	·	·	·	·	·	·	·	CH6		Output DC control				
1	1	1	0	·	·	·	·	·	·	·	·	CH7		Output DC control				
0	0	0	1	·	·	·	·	·	·	·	·	CH8		Output DC control				
1	0	0	1	·	·	·	·	·	·	·	·	CH9		Output DC control				
0	1	0	1	·	·	·	·	·	·	·	·	CH10		Output DC control				
1	1	0	1	·	·	·	·	·	·	·	·	CH11		Output DC control				
0	0	1	1	·	·	·	·	·	·	·	·	CH12		Output DC control				
1	0	1	1	·	·	·	·	·	·	·	·	CH13		Output DC control				
0	1	1	1	1	1	1	1	1	1	1	0	CH14		Output DC control				
1	1	1	1	1	1	1	1	1	1	1	1	CH15		Output DC control				

■ Electrical Characteristics(Continued)

DAC serial data timing

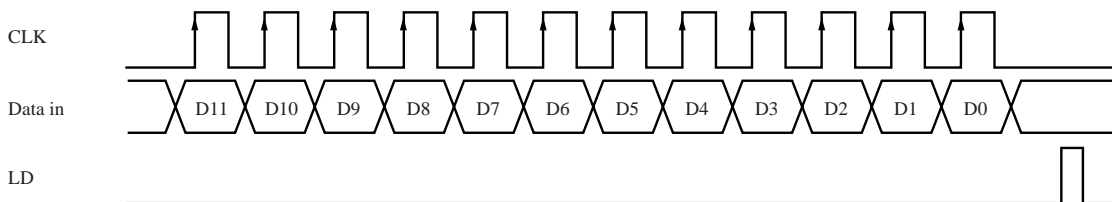

ch.5

AGC output pin signal switching

D7	D6	Function
0	0	CDS signal output at AGC on
1	0	Test signal output at AGC on
1	1	Through output of test signal at AGC off

Pre-apa. on/off

D5	Function
0	Pre-aperture off
1	Pre-aperture on

■ Terminal Equivalent Circuit

Pin No.	Symbol	Equivalent Circuit	Function
1	CH1		0.6 to 2.9 V
2	V _{DD}	—	3.5 V
3	V _{SS}	—	—
4	DI		—
5	SCLK		—

Terminal Equivalent Circuit(Continued)

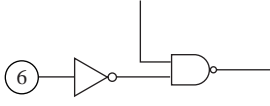
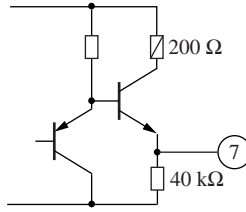
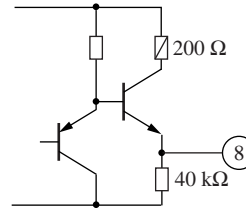
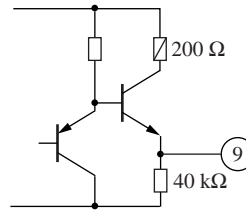
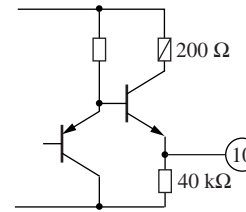
Pin No.	Symbol	Equivalent Circuit	Function
6	LOAD		—
7	CH8		0.15 to 3.60 V
8	CH9		0.15 to 3.60 V
9	CH12		0.15 to 3.60 V
10	CH10		0.15 to 3.60 V

■ Terminal Equivalent Circuit(Continued)

Pin No.	Symbol	Equivalent Circuit	Function
11	CH10		0.15 to 3.60 V
12	CH15		0 to 3.6 V
13	CH14		0 to 3.6 V
14	CH13		0.15 to 3.60 V
15	CH4		0.15 to 3.60 V

■ Terminal Equivalent Circuit(Continued)

Pin No.	Symbol	Equivalent Circuit	Function
16	OB CONT		—
17	A/D OUT		1.0 to 1.4 V
18	SUB DET		—
19	SUB AMP IN		—
20	PREAPA OUT		1.9 V

■ Terminal Equivalent Circuit(Continued)

Pin No.	Symbol	Equivalent Circuit	Function
21	V_{REFM}	—	1.8 V
22	GAMMA IN		—
23	GND2	—	—
24	CPOB IN		—
25	V_{CC2}	—	4.8 V
26	AGC OUT1		1.8 V
27	AGC OUT2		1.8 V

■ Terminal Equivalent Circuit(Continued)

Pin No.	Symbol	Equivalent Circuit	Function
28	PBLK IN		—
29	AGC DET		—
30	AGC IN		—
31	TRAP OUT		2.0 V

■ Terminal Equivalent Circuit(Continued)

Pin No.	Symbol	Equivalent Circuit	Function
32	MODE SW		—
33	AGC REF		1.2 V
34	CDS OUT		1.2 V
35	V _{CC1}	—	—
36	DS2		—

■ Terminal Equivalent Circuit(Continued)

Pin No.	Symbol	Equivalent Circuit	Function
37	DS1		—
38	GND1	—	—
39	CCD IN		—
40	V _{REFMH}	—	2.75 V
41	PREAPA OUT		1.9 V

■ Terminal Equivalent Circuit(Continued)

Pin No.	Symbol	Equivalent Circuit	Function
42	DL IN		—
43	V _{CC3}	—	4.8 V
44	CH6		0.15 to 3.60 V
45	GND2	—	—
46	CH7		0.15 to 3.60 V
47	V _{REFH}	—	3.0 V
48	V _{REFB}	—	1.0 V

■ Application Circuit Example(CCD Camera)

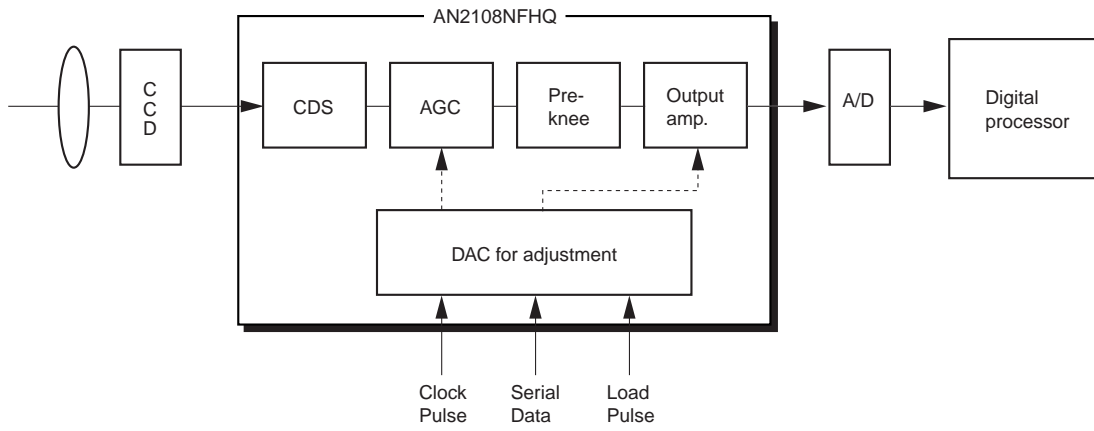

■ Usage Notes

- Supply power to Pins 25,35 and 43 simultaneously.