

# AN2458SH

## Color Encoder IC (NTSC/PAL) for CCD Video Camera

### ■ Overview

The AN2458SH is a color encoder IC for NTSC/PAL-compatible CCD video camera. It outputs chroma signal after modulation of inputted R-Y and B-Y color difference signals with subcarrier signals.

### ■ Features

- Compatible with NTSC and PAL
- Carrier leak adjustment available
- Built-in blanking circuit
- Color phase adjustment available
- Improved temperature characteristics of color phase shift (within  $\pm 5^{\circ}\text{C}$ )

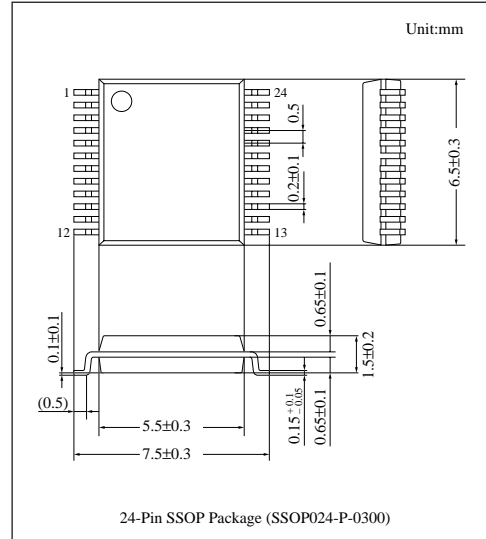

### ■ Block Diagrams

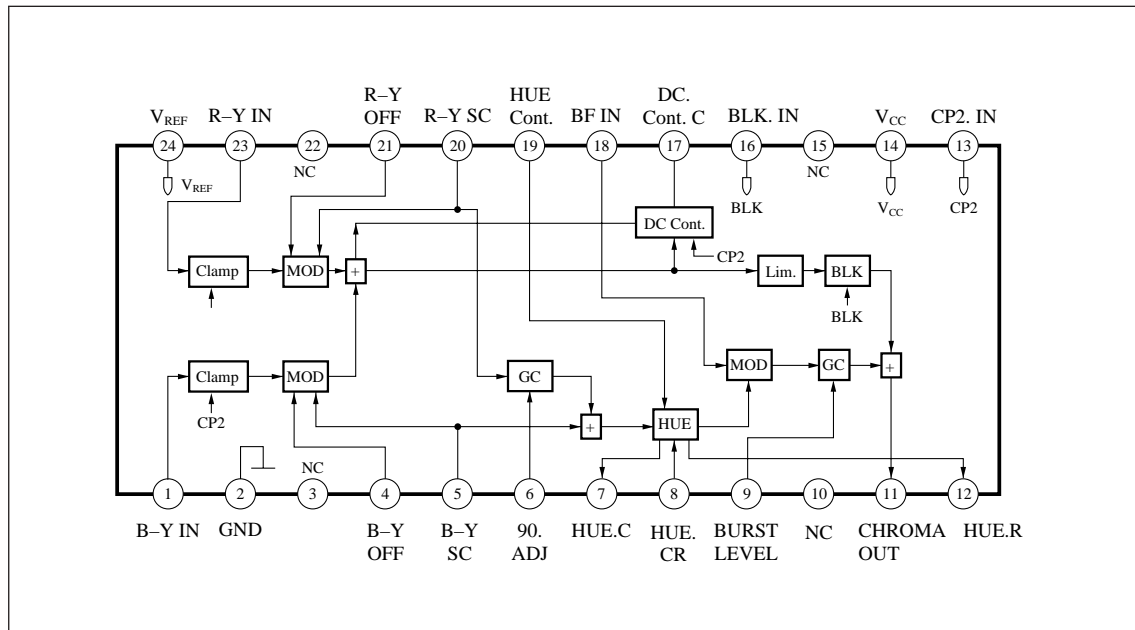

## ■ Absolute Maximum Ratings

Parameter	Symbol	Rating	Unit
Supply voltage	$V_{CC}$	5.5	V
Supply current	$I_{CC}$	25	mA
Power dissipation	$P_D$	120	mW
Operating ambient temperature <sup>Note 1)</sup>	$T_{opr}$	-20 to +75	°C
Storage temperature <sup>Note 1)</sup>	$T_{sig}$	-55 to +125	°C

Note 1)  $T_a=25^{\circ}\text{C}$  except operating ambient temperature and storage temperature.

## ■ Recommended Operating Range ( $T_a=25^{\circ}\text{C}$ )

Parameter	Symbol	Range
Operating supply voltage range	$V_{CC}$	4.6V to 5.0V

## ■ Electrical Characteristics ( $T_a=25\pm 2^{\circ}\text{C}$ )

Parameter	Symbol	Condition	min	typ	max	Unit
Supply current	$I_{CC}$	$V_{CC}=4.8\text{V}$ , $V_{REF}=1.8\text{V}$	12.0	16.0	20.0	mA
CP2 threshold 1	$V_{TH (CP2-1)}$	$V_{CC}=4.8\text{V}$ , $V_{REF}=1.8\text{V}$	1.5	1.8	2.1	V
CP2 threshold 2	$V_{TH (CP2-2)}$	$V_{CC}=4.8\text{V}$ , $V_{REF}=1.8\text{V}$	2.0	2.4	2.8	V
BLK threshold	$V_{TH (BLK)}$	$V_{CC}=4.8\text{V}$ , $V_{REF}=1.8\text{V}$	1.9	2.2	2.5	V
Terminal voltage Pin5	$V_5$	$V_{CC}=4.8\text{V}$ , $V_{REF}=1.8\text{V}$ difference from $V_{REF}$	-100	0	100	mV
Terminal voltage Pin11	$V_{11}$	$V_{CC}=4.8\text{V}$ , $V_{REF}=1.8\text{V}$	1.8	2.3	2.8	V
Terminal voltage Pin20	$V_{20}$	$V_{CC}=4.8\text{V}$ , $V_{REF}=1.8\text{V}$ difference from $V_{REF}$	-100	0	100	mV
R-Y GAIN	$G_{V1}$	$V_{CC}=4.8\text{V}$ , $V_{REF}=1.8\text{V}$ 250mV <sub>P-P</sub> input	480	600	720	mV <sub>P-P</sub>
B-Y GAIN	$G_{V2}$	$V_{CC}=4.8\text{V}$ , $V_{REF}=1.8\text{V}$ 250mV <sub>P-P</sub> input	-7.0	-5.5	-3.5	dB
CHROMA CLIP	$G_{V3}$	$V_{CC}=4.8\text{V}$ , $V_{REF}=1.8\text{V}$ 600mV <sub>P-P</sub> input	0.5	3.0	4.5	dB
BLK CONTROL	$G_{V4}$	$V_{CC}=4.8\text{V}$ , $V_{REF}=1.8\text{V}$ 250mV <sub>P-P</sub> input $BLK=3V_{OP}$	300	600	900	mV <sub>P-P</sub>
BURST GC (1)	$G_{V5}$	$V_{CC}=4.8\text{V}$ , $V_{REF}=1.8\text{V}$ $V_9=V_{REF}$	290	350	430	mV <sub>P-P</sub>
BURST GC (2)	$G_{V6}$	$V_{CC}=4.8\text{V}$ , $V_{REF}=1.8\text{V}$ $V_9=V_{REF}\pm 0.5\text{V}$	1.5	3.0	4.5	dB
BURST GC (3)	$G_{V7}$	$V_{CC}=4.8\text{V}$ , $V_{REF}=1.8\text{V}$ $V_9=V_{REF}-0.5\text{V}$	-6.0	-4.5	-2.5	dB
BURST PHASE (1)	$\theta_1$	$V_{CC}=4.8\text{V}$ , $V_{REF}=1.8\text{V}$ $V_{19}=V_{REF}+0.5\text{V}$	-45	-30	-15	deg
BURST PHASE (2)	$\theta_2$	$V_{CC}=4.8\text{V}$ , $V_{REF}=1.8\text{V}$ $V_{19}=V_{REF}-0.5\text{V}$	0	15	30	deg

## Application Circuit

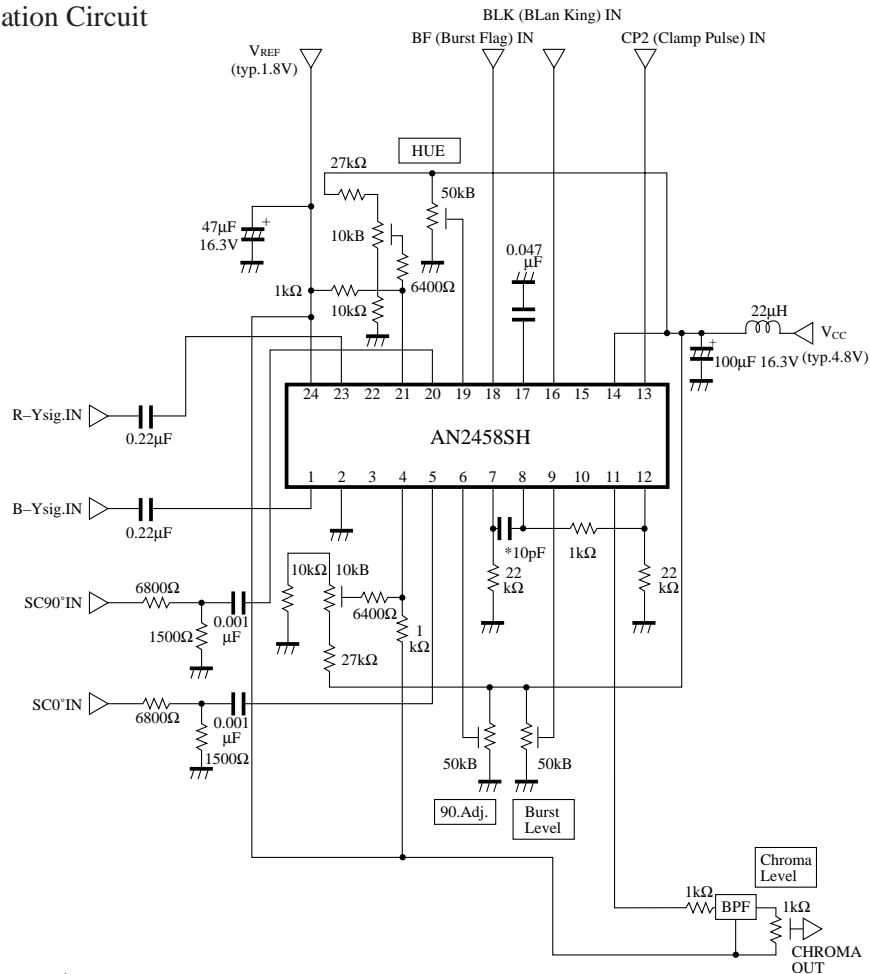

\* The phase-shift capacitor is typically 10 pF for both NTSC and PAL.

## Pin Descriptions

Pin No.	Pin name	Pin No.	Pin name
1	Color difference (B-Y) input	13	Clamp pulse input
2	GND	14	V <sub>CC</sub> (4.8V typ.)
3	N. C.	15	N. C.
4	Subcarrier (0°) OFF	16	Blanking pulse input
5	Subcarrier(0°) input	17	DC playback capacitor
6	90° adjustment	18	Burst flag input
7	Phase-shift capacitor	19	Phase adjustment
8	Phase-shift capacitor	20	Subcarrier (90°/270°) input
9	Burst amplitude adjustment	21	Subcarrier (90°/270°) OFF
10	N. C.	22	N. C.
11	Chroma plus burst output	23	Color difference (R-Y) input
12	Phase-shift resistors	24	V <sub>REF</sub> (1.8V typ.)