

AD20msp410

FEATURES

Passed European GSM Phase I Type Approval
Complete Baseband Processing Chipset Performs:
 Speech Coding/Decoding, According to GSM 06.XX
 DTMF and Call Progress Tone Generation
 Equalization with 16-State Viterbi, Soft Decision
 Channel Coding/Decoding According to GSM 05.03
 All ADC and DAC Interface Functions
 Includes all Radio, Auxiliary and Voice Interfaces
 Support for GSM Data Services
Embedded 16-Bit Microcontroller
Layer 1 Software Provided with Chipset
Full Phase 2 Protocol Stack Software Available
Integrated SIM- and Keyboard Interface
Ultralow Power Design
 2.7 V Operating Voltage
 Intelligent Power Management Features
 Up to 70 Hours Standby Time Achievable
JTAG-Boundary Scan
Full Reference Design Available
Three TQFP Devices, Occupying Less than 12 cm²

APPLICATIONS

GSM/DCS1800 Mobile Radios and PCMCIA Cards

GENERAL DESCRIPTION

The Analog Devices GSM baseband processing chipset provides a competitive solution for GSM based mobile radio systems. It is designed to be fully integrated, easy to use, and compatible with a wide range of product solutions. GSM phones using this chipset and its accompanying Layer 1, 2, 3 software have passed the European GSM full type approval process.

The chipset consists of three highly integrated, sub-micron, low power CMOS components that form the core baseband signal processing of the GSM handset. The system architecture is designed to be easily integrated into current designs and form the basis of next generation of designs.

The chipset uses an operating voltage of 2.7 V to 3.6 V, which coupled with the extensive power management features, significantly reduces the drain on battery power and extends the handset's talktime and standby time.

CHIPSET COMPONENTS

Algorithm Signal Processor (ASP)

The ASP is an application specific variant of the ADSP-2171 standard DSP from Analog Devices. It has been optimized to meet the cost, size and power consumption requirements of GSM mobile applications. All necessary memory to run the GSM specific programs is provided on-chip and with its

REV. 0

Information furnished by Analog Devices is believed to be accurate and reliable. However, no responsibility is assumed by Analog Devices for its use, nor for any infringements of patents or other rights of third parties which may result from its use. No license is granted by implication or otherwise under any patent or patent rights of Analog Devices.

SYSTEM ARCHITECTURE

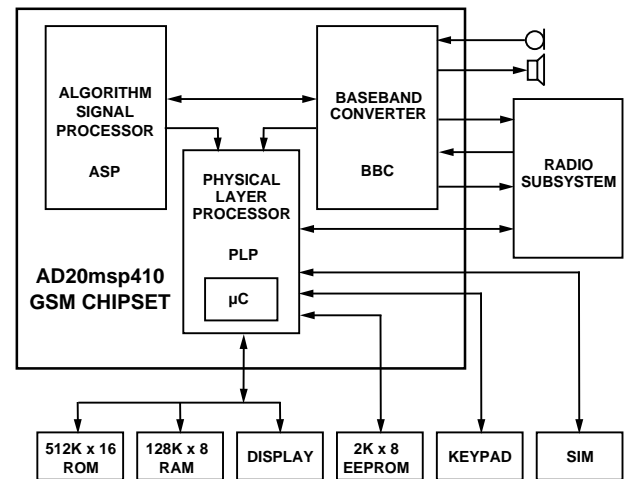

preprogrammed ROM, no user programming is required. The ASP implements full rate speech transcoding according to GSM specifications, including Discontinuous Transmission (DTX) and Comfort Noise Insertion (CNI). A high performance soft-decision Viterbi equalizer is also implemented in software, embedded in the ROM.

Physical Layer Processor (PLP)

The PLP combines application specific hardware and an embedded 16-bit microcontroller (Hitachi H8/300H) to perform channel coding and decoding and execute the protocol stack and user software. The embedded processor executes the Layer 1, 2, 3 and user MMI software. The PLP can control all powerdown functions of the other chips and memory support components to achieve maximum power savings.

Baseband Converter (BBC)

The BBC performs the voiceband and baseband analog-to-digital and digital-to-analog conversions, interfacing the digital sections of the chipset to the microphone, loudspeaker and radio section. In addition, the BBC contains all the auxiliary converters for burst-ramping, AFC, AGC, battery and temperature monitoring. The chipset interfaces directly with a variety of industry standard radio architectures and supplies all the synthesizer and timing control signals.

AD20msp410

Software

The required Layer 1 software is supplied with the chipset. In addition, an object code license for Layers 2 and 3 of the protocol stack is available. This exact package of Layers 1,2,3 of software, coupled with the AD20msp410 chipset, is today in phones that have passed European GSM Final Type Approval.

Architecture Overview

A standard GSM Handset can be divided into five functional areas:

- Analog and Digital Baseband Processing Subsystem (Voice to Radio)
- Layer 1 Software (Physical Layer)
- Protocol Stack Software (Layers 2 and 3)
- Radio Subsystem
- User Interface Software (MMI)

Analog Devices and The Technology Partnership (TTP) provide a cost effective and proven method of attaining the baseband processing subsystem and protocol stack software. This data sheet includes functional descriptions of the baseband processing subsystem and the Layer 1 software. The Technology Partnership can provide licenses to software and reference designs in all the other areas of a GSM hand-portable terminal.

For detailed information about the individual chipset components, please refer to the ADSP-2178 (ASP), AD7015 (BBC) and ADPLP01 (PLP) data sheets for electrical characteristics and timing information.

FUNCTIONAL DESCRIPTION

Figure 1 is a functional block diagram of the GSM baseband processing chipset. The chipset can be viewed as a functional block that contains a number of discrete functional units. The electrical and functional interfaces to the rest of the system are briefly described at the end of this section and described in detail in the individual data sheets for each component.

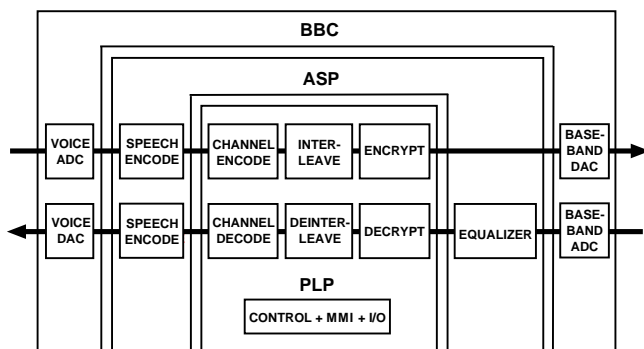

Figure 1. Functional Description

UPLINK

The uplink baseband processing functions include the following operations:

Analog-to-Digital Voice Conversion (BBC)

A conventional microphone, connected directly to the BBC, provides an analog input signal to the ADC. The voice ADC function uses a sigma-delta converter to convert and noise shape the input signal, achieving a Signal-to-Noise Ratio plus Total Harmonic Distortion (SNR+THD) of greater than 62.5 dB.

The analog voice signal is sampled at 8 kHz, producing 13-bit linear values corresponding to the magnitude of the input. The resulting data is passed to the ASP through a dedicated serial port.

Speech Encoding (ASP)

The ASP receives the voice data stream from the BBC and encodes the data from 104 kb/s to 13 kb/s. The algorithm used is Regular Pulse Excitation, with Long Term Prediction (RPE-LTP) as specified in the 06-series of GSM recommendations. The algorithm is tested and proven to be bit-exact against the GSM test vectors including all VAD/DTX functions. After encoding the data is transferred to the PLP through a parallel port in discrete blocks of 260 bits at 20 ms intervals.

Channel Coding (PLP)

The information received from the ASP contains data values and filter coefficients that have different levels of priority. These are subsequently protected to different levels within the channel coding. The encode protection process incorporates block coding and convolutional encoding. In addition to the normal speech traffic channels, the channel coding function also supports data transmission at full rate and half rate. After the interleave process, if necessary, the data is encrypted using the required A5/1 or A5/2 encryption algorithm. Data is then formatted into bursts, with the required timing and training sequences and sent to the BBC through a dedicated serial port.

GMSK Modulation and D/A Conversion (BBC)

The BBC receives data at 270 kb/s. The on-chip lookup-table ROM modulates and spectrally shapes the data being sent. A pair of 10-bit matched differential DACs convert the modulated data from the digital domain to the analog domain and pass I and Q data to the transmit section of the radio subsystem.

DOWNLINK

The downlink baseband processing functions include the following operations:

Analog-to-Digital Conversion (BBC)

The receiver I and Q signals are sampled by a pair of ADCs at 270 kHz. The resulting digital words are transferred to the ASP through a dedicated receive path serial link and DMA control.

Equalization (ASP)

The equalizer recovers and demodulates the received signal and establishes local timing and frequency references for the mobile unit. The equalization algorithm is a version of the Maximum Likelihood Sequence Estimation (MLSE) using the Viterbi algorithm. Two confidence bits per symbol provide additional information about the accuracy of each decision to the channel codec's convolutional decoder. The equalizer outputs a sequence of bits including the confidence bits. This data is transferred to the PLP through a dedicated parallel port on the ASP. At this point, the training sequence and trailing bits, contained within the burst, are discarded.

Channel Decoding (PLP)

The A5/1 or A5/2 decryption algorithm is used, as required, to recover the data that is ready for the deinterleave process. The deinterleave process is an exact inversion of the interleave process used by the transmit section. Data can pass directly to this function, without the A5/1 or the A5/2 decryption, controlled by the Layer 1 processing. The decode function then performs convolutional decoding and parity decoding. The convolutional decoder uses a Viterbi algorithm, with two soft

decision confidence bits supplied by the equalizer. Once these decoding functions are complete, digitized voice data is transferred to the ASP through a parallel port. Error control mechanisms are used to ensure adequate bad frame indication.

Speech Decoding (ASP)

Encoded speech data is transferred at 20 ms intervals from the PLP to the ASP in blocks of 260 bits plus the Bad Frame Indicator (BFI). The speech decoder supports a Comfort Noise Insertion (CNI) function that inserts a predefined silence descriptor into the decoding process. The ASP also implements control of talker side-tone and short term echo cancellation. The resulting data, at 104 kb/s, is transferred to the BBC through a dedicated serial path.

Voice Digital-to-Analog Conversion

The Voice DAC function of the BBC uses a sigma-delta converter to convert and noise shape the signal. The 13-bit linear values are converted to the analog domain and filtered to avoid any images. The resulting differential signals can be controlled in volume and drive directly a small earpiece as well as a separate auxiliary output.

AUXILIARY SYSTEM FUNCTIONS

The ASP, the PLP and the BBC perform a number of auxiliary functions which are essential to build a complete mobile radio.

A general radio section constitutes the three functions of transmitter, receiver and synthesizer. Figure 2 shows how the baseband chipset interfaces to a typical radio architecture. The transmitter is fed with baseband analog I and Q signals from the

BBC and upconverted to 900 MHz for GSM applications and 1800 MHz for PCN applications.

A dedicated power amplifier increases the RF-signal to the required level. The receiver amplifies the antenna signal, down-converts it to an intermediate frequency (IF) and amplifies it there again. After second conversion to baseband, the I and Q components of the signal are fed into the BBC.

The BBC, ASP and PLP provide three auxiliary functions for interfacing to the radio subsystem. These auxiliary functions include AGC, AFC and Power Ramping.

Power Ramp Envelope (BBC)

To meet the spectral and time-domain specifications of the transmitted output signal, the burst has to follow a specified power envelope. The envelope for the power profile originates in the PLP as a set of coefficients, down-loaded and stored in the BBC. This envelope profile is sent to one of the auxiliary DACs on the BBC with each burst. The analog output is fed into the RF power amplifier, controlling the power profile and absolute level of the transmitted data.

Automatic Gain Control (AGC)

The mobile radio has to cope with a wide range of input signal levels. The major part of the overall gain is provided in the IF amplifier. The incoming signal level is analyzed in the ASP and the PLP and a digital gain control signal is sent to the BBC. A 10-bit auxiliary DAC generates the appropriate analog control signal for the IF amplifier. Additionally gain control can be implemented by using two output flags of the ASP.

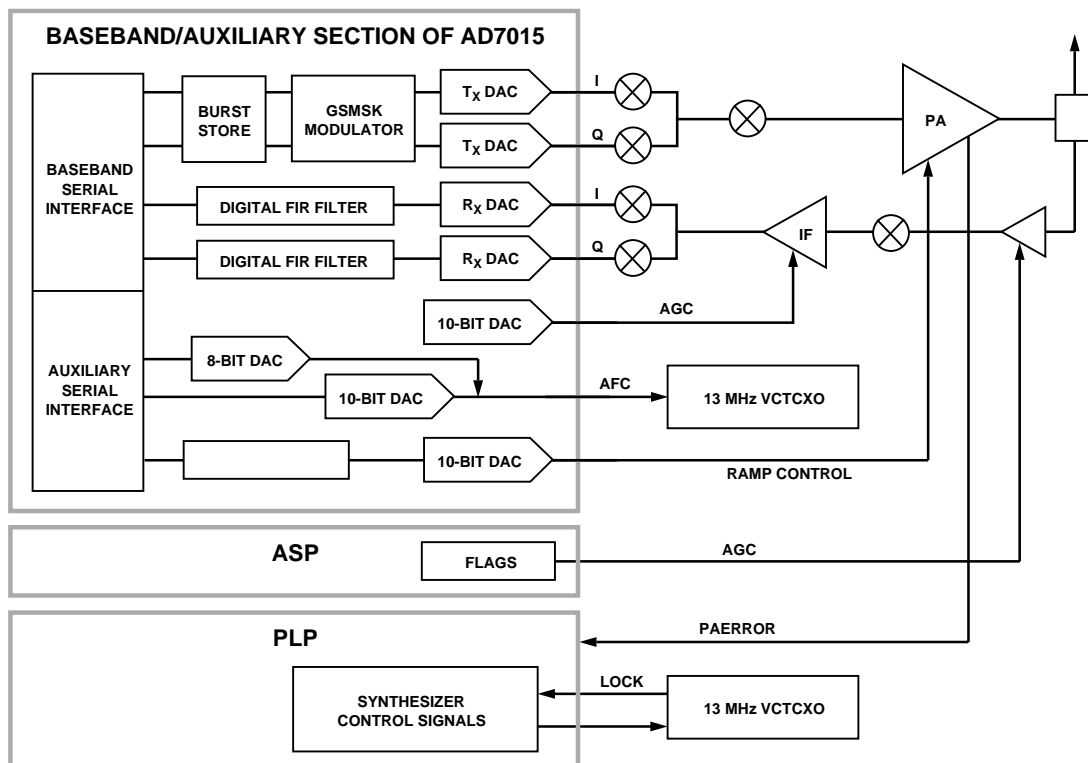

Figure 2. Control of RF Section

AD20msp410

Automatic Frequency Control (AFC)

The mobile radio has to track precisely the master clock provided by the base station. Drift of the crystal oscillator over time and temperature has to be compensated as well as frequency shifts due to the Doppler effect in the case of a moving mobile radio. The received signal is analyzed in the ASP and the PLP and a digital control signal is generated. This signal is sent to the two DACs in the BBC. The 10-bit DAC operates as coarse and the 8-bit DAC as fine adjust. The weighting of the DACs is such, that both DACs yield a combined resolution of 13 bits. The combined analog output signal is used to control the voltage controlled, temperature compensated crystal oscillator (VCTCXO).

Synthesizer Control

The PLP and the respective parts of the Layer 1 software control the overall timing and frequency generation of the radio subsystem. This includes control signals for up to two synthesizers, powerdown control signals and power amplifier monitor signals. Detailed information can be found in the ADPLP01 data sheet.

Generation of Auxiliary Audio Signals

Under control of Layer 1 the ASP can generate a variety of fixed and user-programmable tones. This includes all standard DTMF and Call Progress tones as well as user defined tones. The tone structure can consist of up to four frequency components with individual durations.

The ASP also generates Talker Sidetone as specified in the GSM recommendations. In comparison to traditional hardware implementations, this software implementation provides manufacturing flexibility over a wide range of speaker/microphone sensitivities.

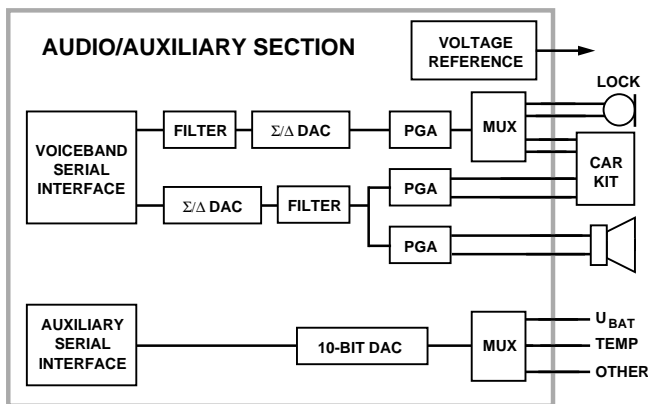

Figure 3. Audio-/Auxiliary Section of AD7015

Figure 3 shows the audio section and the auxiliary ADC of the BBC. Input signals can come from either a directly connected microphone or from a remote microphone in a car kit. Input gain can be set to 0 dB or +26 dB. The output signal can be directly connected to a small earpiece and, for further amplification, to an external car-kit. Two output-PGAs can be programmed for -15 dB or +6 dB.

DATA SERVICES

Data Services is considered to be an essential feature for GSM terminals and the AD20msp410 chipset is designed to provide flexible and low cost implementation of Data Services supported via the GSM air interface.

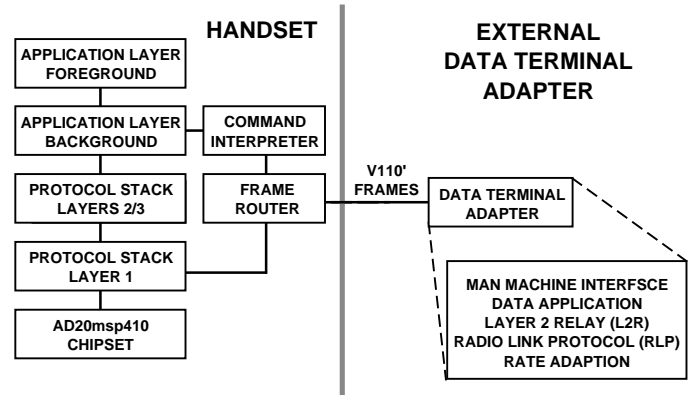

Figure 4. Implementation of Data Services

The selected system architecture shown in Figure 4 provides for minimum terminal Bill of Materials, the lowest possible number of interconnection points and the lowest power consumption when running speech traffic only. However, the chipset provides full channel coding and decoding for all Data Services. Parity and convolutional encoding and interleaving for TCH/F9.6, TCH/F4.8 and TCH/F2.4 are implemented in the PLP.

The interface to the chipset is a user-configurable, 3-wire serial interface supplying V110 data packets as defined in GSM 05.03, combined with protocol information and control to the Application Layer. External to the terminal is the Data Terminal Adapter (DTA) which runs the Data Services Software. Included in the DTA are the rate adaptation functions and the Data Services application. The Command Interpreter resident on the mobile supports a serial interface protocol with the DTA via both traffic data and control information are communicated. The Technology Partnership can provide all requisite Data Services Software.

SOFTWARE IMPLEMENTATIONS

A full implementation of the GSM Layer 1 functionality is supplied as an object code module, for execution on the controller, embedded in the PLP. Functions performed by this software include:

- Initial scan of GSM band and selection of strongest thirty channels as required by 03.22 and 05.08
- Mobile oscillator adjustment, timing synchronization and BCCH decoding from serving cell (camping-on)
- Base station frequency and timing measurements and BSIC extraction from neighbor cells under control of Layer 3
- Frequency hopping according to 05.02
- Full implementation of discontinuous reception (DRX) and transmission (DTX)
- Reporting of received level and signal quality

- Full engineering and test mode support
- Support for all phase 1 and phase 2 handover modes
- SIM Interface driver
- Message interfacing to Layer 3 (Radio Resources Manager) and Layer 2 (data link layer, both signaling and data)
- External functions for AGC, AFC and synthesizer setting are called by Layer 1. These allow the user to configure the system for a wide range of radio architectures including the TTP GSM reference radio.
- The higher layers of the protocol stack also reside on this embedded processor. A GSM Phase 2 compliant, Layer 2/3 protocol stack is available from The Technology Partnership.

POWER DISSIPATION CONSIDERATIONS

In mobile applications, minimizing the power consumption of all devices is critical to achieving longer standby and talk times. In a GSM handset the baseband subsystem dominates the current consumption of the phone in standby. The design of the ASP, PLP and BBC includes extensive features to reduce current consumption and give standby times of up to 70 hours.

All three devices were specifically designed to operate from 2.7 V to 3.6 V, so facilitating three or four cell NiCad/NiMH or single-cell Li Ion batteries.

The PLP incorporates intelligent power management, permitting automatic control of power consumption in the PLP and the peripheral circuitry. Data processing modules are switched on only when they process data, otherwise they are powered down.

Additional control signals are provided that enable the Layer 1 software to control the external subsystems, such as the ASP, BBC, radio and memory components, so that their power is intelligently switched by the PLP.

Within the ASP the different powerdown modes range from a simple “wait for interrupt” state to a complete hardware powerdown, with only leakage currents dissipating power.

In the BBC, the powerdown functions are split separately between receive, transmit and auxiliary circuits. This provides optimal analog power performance when operating in different modes.

INTERFACES

Figure 5 shows the chipset’s eight interfaces, which have to be considered in the design of the complete mobile radio. Some of these interfaces have to meet GSM specifications, others will be design specific.

- Analog Voice Interface to BBC
- Radio Interface to BBC and PLP
- Digital SIM Card Interface to PLP
- Digital Interface to the Keypad
- Digital Bus Interface from PLP to Memory and Display
- Digital Interface from the PLP to the EEPROM
- Digital Audio Interface (DAI)
- Digital Interface to PLP for Data Services

Analog Voice Interface to BBC

The analog voice interface to the BBC is specified in the AD7015 data sheet. Several design examples are given for single-ended or differential inputs or outputs. A voltage reference for biasing the microphone signal is provided on the BBC. The analog output of the BBC is capable of driving an earpiece directly with and impedance of 150 Ω . For optional use of a separate external microphone and power amplifier, a set of auxiliary inputs/outputs is provided.

Radio Interface to BBC and PLP

The analog interface between the BBC and the radio subsystem consists of differential inputs and outputs for the I and Q parts of the signal and three analog control signals for AFC, AGC and transmit ramp envelope. Details of these signals are specified in the AD7015 data sheet. The digital interface between the PLP and the radio subsystem consists of a serial port for communicating with the synthesizers and several control signals as specified in detail in the ADPLP01 data sheet.

Digital SIM Card Interface to PLP

The PLP is designed to interface directly to the SIM. However interface logic may be necessary to connect the 3 V chipset to a 5 V SIM.

Digital Interface to Keypad

Keypad interface logic for up to 40 keys is provided on the PLP. This interface provides keyboard scan for 8 Rows and 4 columns. Additionally an extra pin on the PLP is provided for the power switch.

Digital Bus Interface to Memory and Display

External RAM and ROM as well as the display controller interfaces directly to the 21-bit address bus and 16-bit data bus of the PLP.

Interface to FLASH Memory

The large FLASH memory can contain all programs for the embedded Control Processor of the PLP. This includes the complete GSM protocol software as well as the User Interface Software. A size of 4 Mbit to 8 Mbit is suggested to accommodate all Protocol software plus a typical size of User Interface Software. Enhanced features, requiring larger memories are supported easily by the large address space of the embedded Control Processor. To facilitate production programming and field upgrades of the FLASH memories, the PLP provides embedded code to download the software into the FLASH memory via its standard serial port.

Interface to SRAM

Beside the FLASH memory, the Control Processor additionally supports static RAM to store user defined variables, typically those used by the Protocol Stack or Application Layer. Standard SRAMs interface directly to the address and data bus of the PLP.

Interface to Display Controller

This interface is achieved through the address and data buses and associated read and write strobes, as well as a specific enable signal. An integrated wait state generator helps interface to a wide range of display controllers. Two pins with PWM outputs control the intensity of separate backlights for display and keypad.

AD20msp410

Digital Audio Interface (DAI)

As required by the GSM specifications, a digital audio interface is provided to allow certain tests of the audio section during type approval. This interface is provided by the serial bus between the ASP and the PLP and two additional control signals from the PLP. A fully functional “DAI Box” needed for the FTA process may be obtained from Analog Devices upon request.

Digital Interface to the PLP for Data Services

A conventional H8 serial port combined with a proprietary protocol is used to interface to an external Data Terminal Adapter.

Digital Interface from the PLP to the EEPROM

The PLP provides separate pins to interface directly to an external EEPROM via a serial port. This EEPROM is typically used for storage of calibration or user variable parameters like handset identifier (IMEI), language, keypad lock and radio calibration parameters. A typical size of the EEPROM is 2K × 8 bits, but this depends on the individual design of the handset.

GSM Baseband Processing Key Parts List

Table 1 lists the major hardware components necessary to complete the GSM baseband processing subsystem. An example Bill Of Material is available from Analog Devices. A full reference design is available through Analog Devices/The Technology Partnership.

Table I. List of Key Components

Quantity	Description	Specification
1	ASP ¹	ADSP-2178
1	PLP ¹	ADPLP01
1	BBC ¹	AD7015
1	FLASH-PROM ²	256K × 16, 150 ns
1	SRAM	128K × 8, 120 ns
1	EEPROM ³	2K × 8
1	Display Driver	Design Specific

NOTES

¹These components comprise the AD20msp410 chipset.

²A size of 4 Mbits is recommended to allow storage of all GSM Layer (1, 2, 3) programs as well as a typical user interface (MMI). Larger memory can be used to support enhanced user interfaces.

³Can be omitted if parameters are stored in FLASH memory.

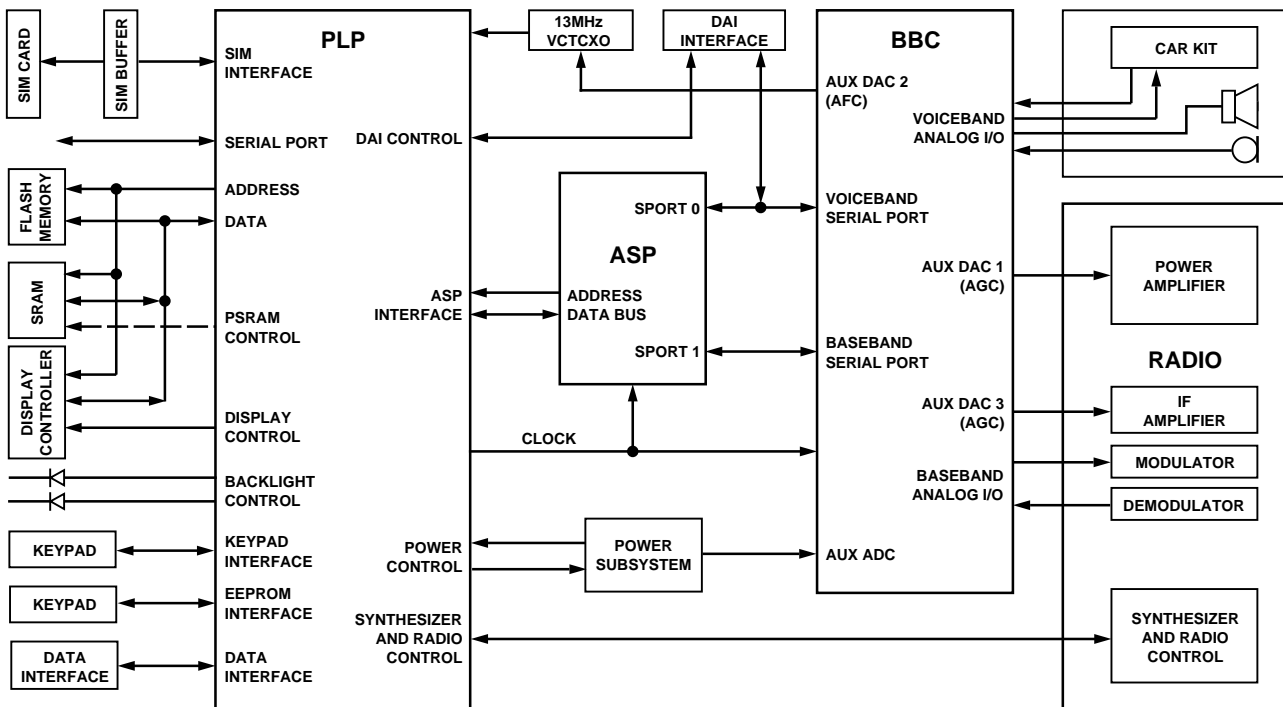

Figure 5. System Interfaces

Mechanical Considerations

The chipset has been specifically designed to meet not only cost and power consumption requirements but also attention was paid to the physical dimensions. State-of-the-art package technology was used to achieve smallest possible geometries. See Table II for a list of main packaging dimensions and consult individual data sheets of the three components for further details.

Table II. Package Dimensions

Parameter	ASP	PLP	BBC	Unit
Package	TQFP	TQFP	TQFP	
Leads	100	176	80	
Pitch	0.5	0.5	0.65	mm
Body	14 × 14	24 × 24	14 × 14	mm ²
Total Height	1.6	1.7	1.6	mm
Board Area	16 × 16	26 × 26	16 × 16	mm ²

All three components utilize low profile Plastic Quad Flat Packs with lead pitches of 0.5 mm minimum. Special attention was paid to the possible use in PCMCIA cards.

ORDERING GUIDE

To order the parts for the AD20msp410 GSM chipset, please order one of each of the following components.

Part	Part Number	Supply Voltage Range
ASP	ADSP-2178-780244	+2.7 V to 3.6 V
BBC	AD53/009-9 (Special AD7015)	+2.7 V to 3.6 V
PLP	ADPLP01	+2.7 V to 3.6 V

An evaluation and development system may be ordered for this chipset, under the part number, AD20msp410-EB03.

AD20msp410

000000000

PRINTED IN U.S.A.