

# IR Receiver Modules for Remote Control Systems

## Description

The TSOP362.. - series are miniaturized SMD-IR Receiver Modules for infrared remote control systems. PIN diode and preamplifier are assembled on lead frame, the epoxy package is designed as IR filter.

The demodulated output signal can directly be decoded by a microprocessor. TSOP362.. is the standard IR remote control SMD-Receiver series, for 3 V supply voltage supporting all major transmission codes.

This component has not been qualified according to automotive specifications.

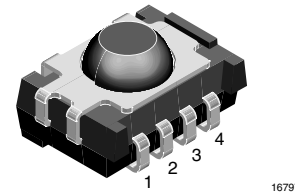

## Features

- Photo detector and preamplifier in one package
- Internal filter for PCM frequency
- Continuous data transmission possible
- TTL and CMOS compatibility
- Output active low
- Low power consumption
- High immunity against ambient light
- Supply voltage: 2.7 V to 5.5 V
- Lead (Pb)-free component
- Component in accordance to RoHS 2002/95/EC and WEEE 2002/96/EC



## Mechanical Data

### Pinning:

1 = GND, 2 = GND, 3 =  $V_S$ , 4 = OUT

## Parts Table

Part	Carrier Frequency
TSOP36230	30 kHz
TSOP36233	33 kHz
TSOP36236	36 kHz
TSOP36237	36.7 kHz
TSOP36238	38 kHz
TSOP36240	40 kHz
TSOP36256	56 kHz

## Special Features

- Improved immunity against ambient light
- Suitable burst length ( $\geq 10$  cycles/burst)
- Taping available for topview and sideview assembly

## Block Diagram

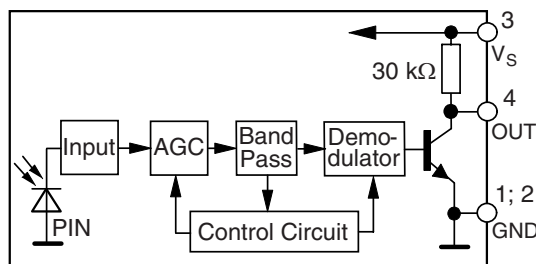

16839

## Application Circuit

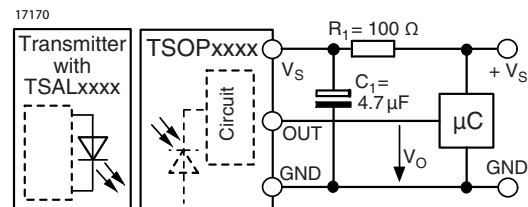

$R_1$  and  $C_1$  recommended to suppress power supply disturbances. The output voltage should not be hold continuously at a voltage below  $V_o = 2.0$  V by the external circuit.

**Absolute Maximum Ratings**

T<sub>amb</sub> = 25 °C, unless otherwise specified

Parameter	Test condition	Symbol	Value	Unit
Supply Voltage	Pin 3	V <sub>S</sub>	- 0.3 to + 6.0	V
Supply Current	Pin 3	I <sub>S</sub>	3	mA
Output Voltage	Pin 4	V <sub>O</sub>	- 0.3 to (V <sub>S</sub> + 0.3)	V
Output Current	Pin 4	I <sub>O</sub>	10	mA
Junction Temperature		T <sub>J</sub>	100	°C
Storage Temperature Range		T <sub>stg</sub>	- 40 to + 100	°C
Operating Temperature Range		T <sub>amb</sub>	- 25 to + 85	°C
Power Consumption	T <sub>amb</sub> ≤ 85 °C	P <sub>tot</sub>	30	mW

**Electrical and Optical Characteristics**

T<sub>amb</sub> = 25 °C, unless otherwise specified

Parameter	Test condition	Symbol	Min	Typ.	Max	Unit
Supply Current	E <sub>v</sub> = 0	I <sub>SD</sub>	0.7	1.2	1.5	mA
	E <sub>v</sub> = 40 klx, sunlight	I <sub>SH</sub>		1.3		mA
Supply Voltage		V <sub>S</sub>	2.7		5.5	V
Transmission Distance	E <sub>v</sub> = 0, test signal see fig. 1, IR diode TSAL6200, I <sub>F</sub> = 250 mA	d		35		m
Output Voltage Low	I <sub>OSL</sub> = 0.5 mA, E <sub>e</sub> = 0.7 mW/m <sup>2</sup> , test signal see fig. 1	V <sub>OSL</sub>			250	mV
Minimum Irradiance (30 - 40 kHz)	V <sub>S</sub> = 3 V Pulse width tolerance: t <sub>pi</sub> - 5/f <sub>o</sub> < t <sub>po</sub> < t <sub>pi</sub> + 6/f <sub>o</sub> , test signal see fig. 1	E <sub>e min</sub>		0.35	0.5	mW/m <sup>2</sup>
Minimum Irradiance (56 kHz)	V <sub>S</sub> = 3 V Pulse width tolerance: t <sub>pi</sub> - 5/f <sub>o</sub> < t <sub>po</sub> < t <sub>pi</sub> + 6/f <sub>o</sub> , test signal see fig. 1	E <sub>e min</sub>		0.4	0.6	mW/m <sup>2</sup>
Minimum Irradiance (30 - 40 kHz)	V <sub>S</sub> = 5 V Pulse width tolerance: t <sub>pi</sub> - 5/f <sub>o</sub> < t <sub>po</sub> < t <sub>pi</sub> + 6/f <sub>o</sub> , test signal see fig. 1	E <sub>e min</sub>		0.45	0.6	mW/m <sup>2</sup>
Minimum Irradiance (56 kHz)	V <sub>S</sub> = 5 V Pulse width tolerance: t <sub>pi</sub> - 5/f <sub>o</sub> < t <sub>po</sub> < t <sub>pi</sub> + 6/f <sub>o</sub> , test signal see fig. 1	E <sub>e min</sub>		0.5	0.7	mW/m <sup>2</sup>
Maximum Irradiance	t <sub>pi</sub> - 5/f <sub>o</sub> < t <sub>po</sub> < t <sub>pi</sub> + 6/f <sub>o</sub> , test signal see fig. 3	E <sub>e max</sub>	30			W/m <sup>2</sup>
Directivity	Angle of half transmission distance	φ <sub>1/2</sub>		± 45		deg

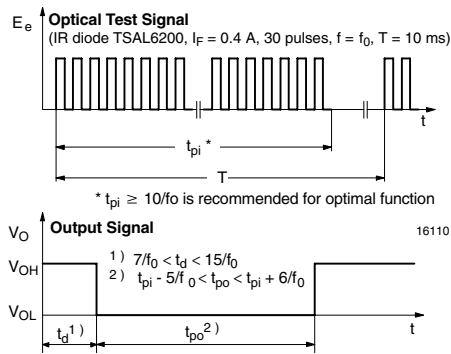
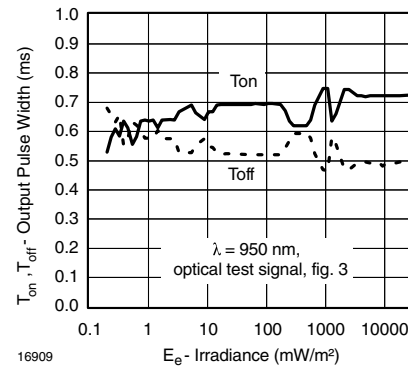
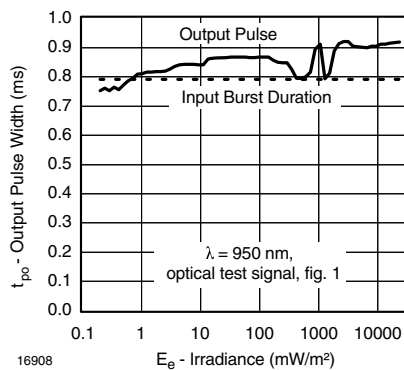
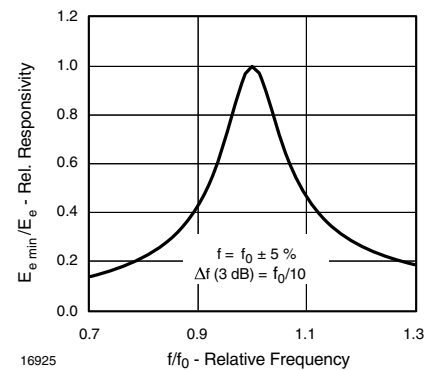
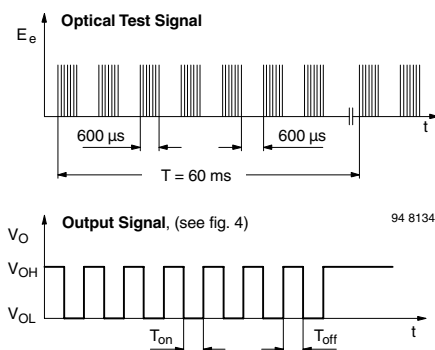
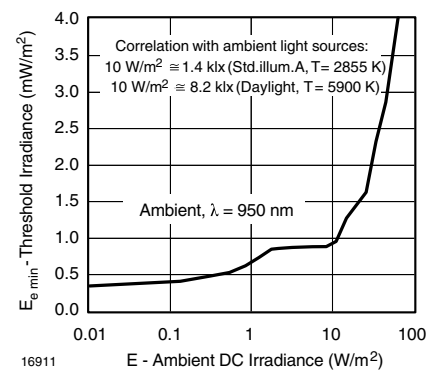
**Typical Characteristics**
 $T_{amb} = 25\text{ }^{\circ}\text{C}$ , unless otherwise specified

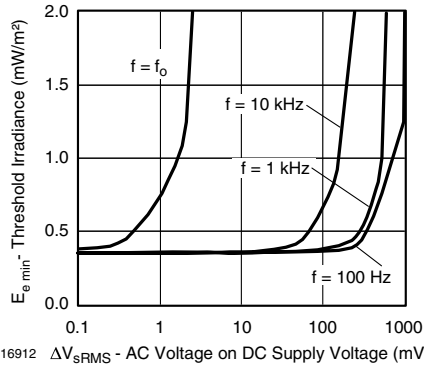
**Figure 1. Output Function**

**Figure 4. Output Pulse Diagram**

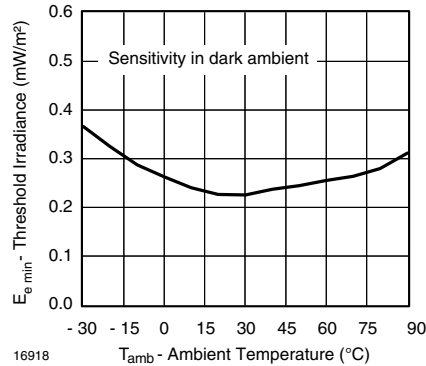
**Figure 2. Pulse Length and Sensitivity in Dark Ambient**

**Figure 5. Frequency Dependence of Responsivity**

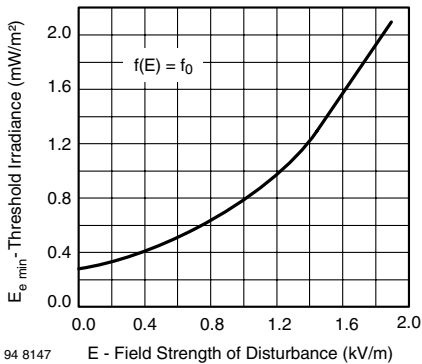
**Figure 3. Output Function**

**Figure 6. Sensitivity in Bright Ambient**



16912  $\Delta V_{sRMS}$  - AC Voltage on DC Supply Voltage (mV)  
 Figure 7. Sensitivity vs. Supply Voltage Disturbances



16918  $T_{amb}$  - Ambient Temperature (°C)  
 Figure 10. Sensitivity vs. Ambient Temperature



94 8147 E - Field Strength of Disturbance (kV/m)  
 Figure 8. Sensitivity vs. Electric Field Disturbances

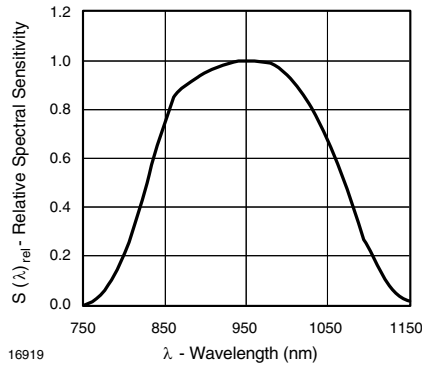

16919  $\lambda$  - Wavelength (nm)  
 Figure 11. Relative Spectral Sensitivity vs. Wavelength

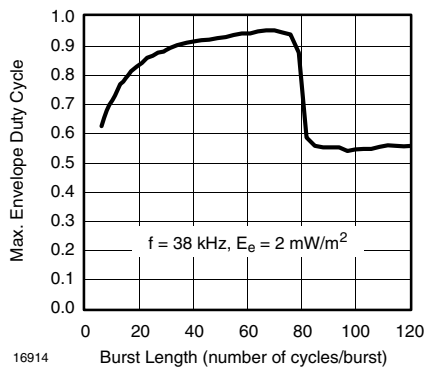

16914 Burst Length (number of cycles/burst)  
 Figure 9. Max. Envelope Duty Cycle vs. Burstlength

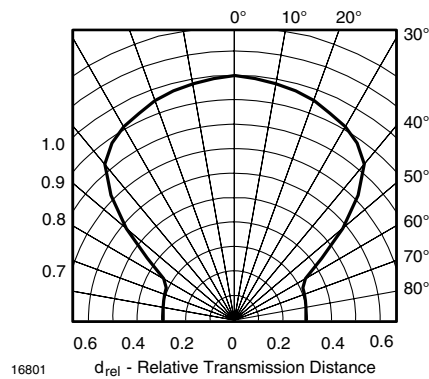

16801  $d_{rel}$  - Relative Transmission Distance  
 Figure 12. Directivity

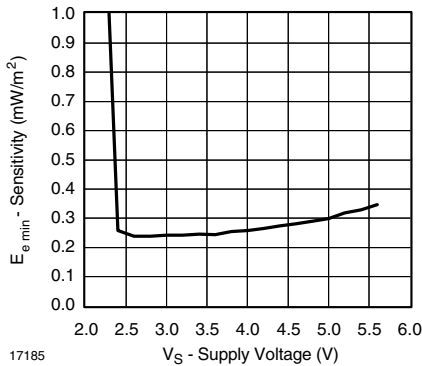

Figure 13. Sensitivity vs. Supply Voltage

### Suitable Data Format

The circuit of the TSOP362.. is designed so that unexpected output pulses due to noise or disturbance signals are avoided. A bandpass filter, an integrator stage and an automatic gain control are used to suppress such disturbances.

The distinguishing mark between data signal and disturbance signal are carrier frequency, burst length and duty cycle.

The data signal should fulfill the following conditions:

- Carrier frequency should be close to center frequency of the bandpass (e.g. 38 kHz).
- Burst length should be 10 cycles/burst or longer.
- After each burst which is between 10 cycles and 70 cycles a gap time of at least 14 cycles is necessary.
- For each burst which is longer than 1.8 ms a corresponding gap time is necessary at some time in the data stream. This gap time should be at least 6 times longer than the burst.
- Up to 800 short bursts per second can be received continuously.

Some examples for suitable data format are: NEC Code (repetitive pulse), NEC Code (repetitive data), Toshiba Micom Format, Sharp Code, RC5 Code, RC6 Code, R-2000 Code, Sony Code.

When a disturbance signal is applied to the TSOP362.. it can still receive the data signal. However the sensitivity is reduced to that level that no unexpected pulses will occur.

Some examples for such disturbance signals which are suppressed by the TSOP362.. are:

- DC light (e.g. from tungsten bulb or sunlight)

- Continuous signal at 38 kHz or at any other frequency
- Signals from fluorescent lamps with electronic ballast with high or low modulation (see Figure 14 or 15).

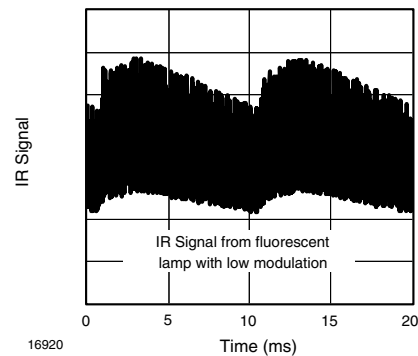

Figure 14. IR Signal from Fluorescent Lamp with low Modulation

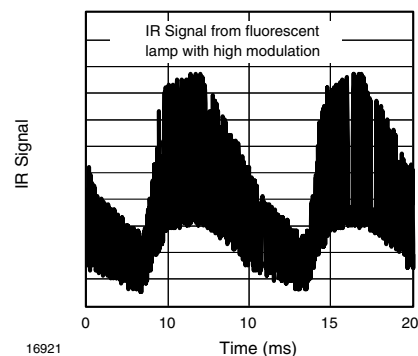
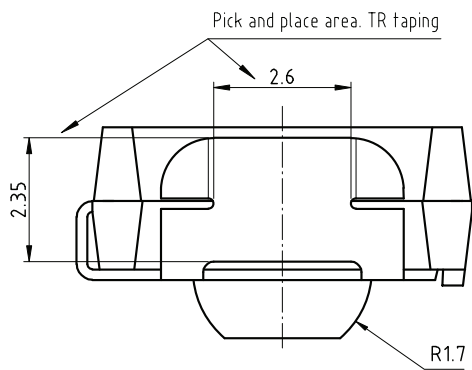
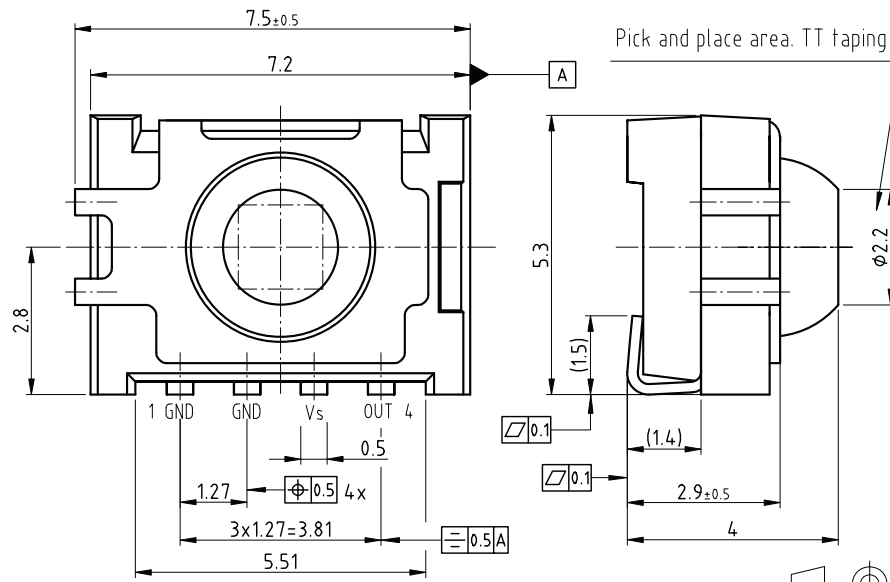

Figure 15. IR Signal from Fluorescent Lamp with high Modulation

Package Dimensions



Not indicated tolerances ±0.3

Technical drawings according to DIN specifications

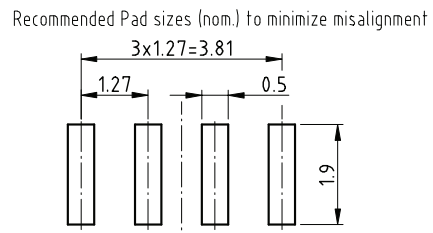
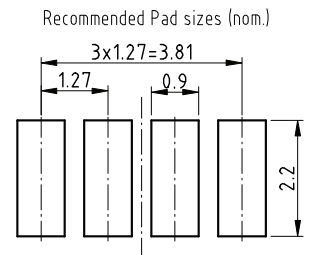

Drawing-No.: 6.544-5341.02-4  
 Issue: 7; 11.10.06  
 16629

## Assembly Instructions

### Reflow Soldering

- Reflow soldering must be done within 72 hours while stored under a max. temperature of 30 °C, 60 % RH after opening the dry pack envelope.
- Set the furnace temperatures for pre-heating and heating in accordance with the reflow temperature profile as shown in the diagram. Exercise extreme care to keep the maximum temperature below 260 °C. The temperature shown in the profile means the temperature at the device surface. Since there is a temperature difference between the component and the circuit board, it should be verified that the temperature of the device is accurately being measured.
- Handling after reflow should be done only after the work surface has been cooled off.

### Manual Soldering

- Use a soldering iron of 25 W or less. Adjust the temperature of the soldering iron below 300 °C.
- Finish soldering within three seconds.
- Handle products only after the temperature has cooled off.

## Vishay Lead (Pb)-free Reflow Solder Profile

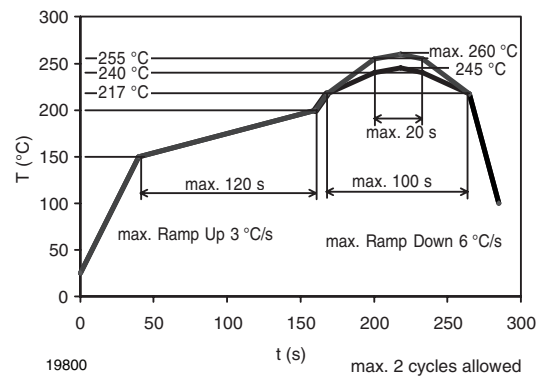

Taping Version TSOP..TT Dimensions in millimeters

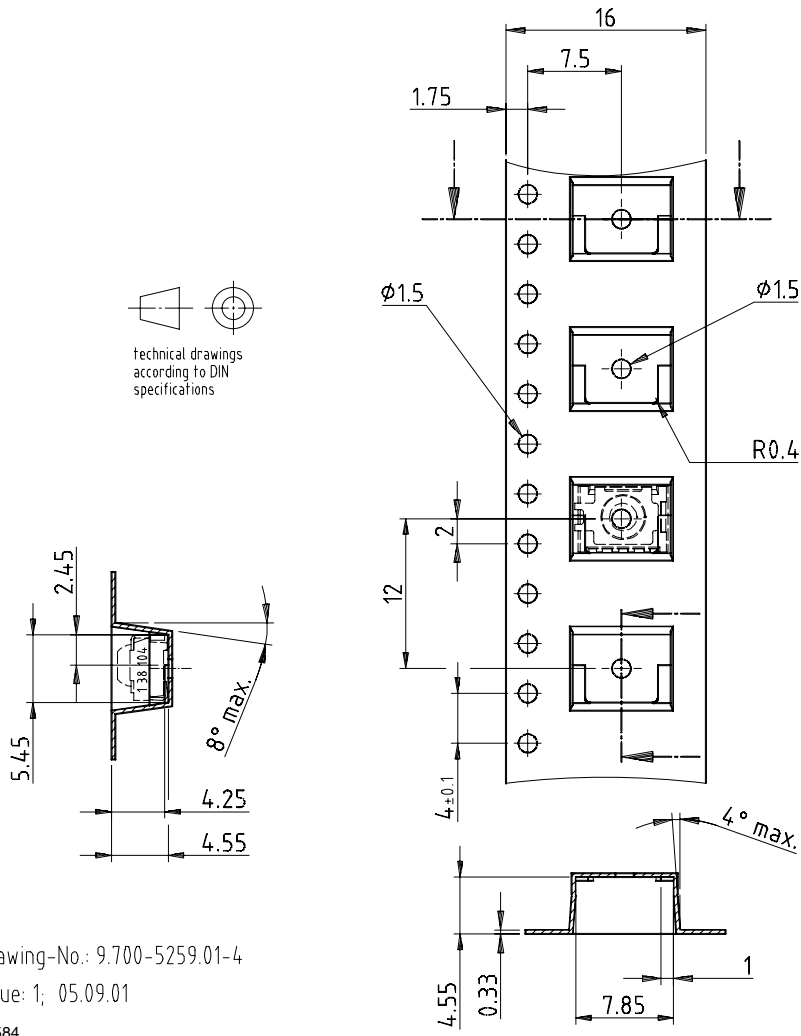

Drawing-No.: 9.700-5259.01-4

Issue: 1; 05.09.01

16584



**Taping Version TSOP..TR** Dimensions in millimeters

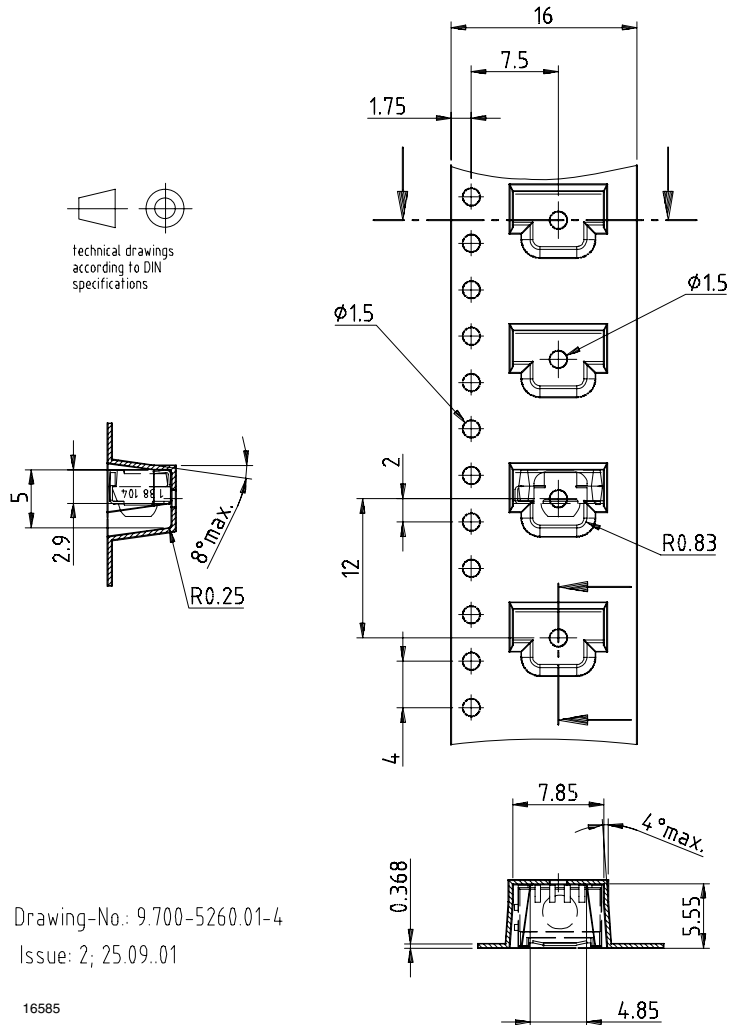

Drawing-No.: 9.700-5260.01-4  
 Issue: 2; 25.09.01

16585

Reel Dimensions in millimeters

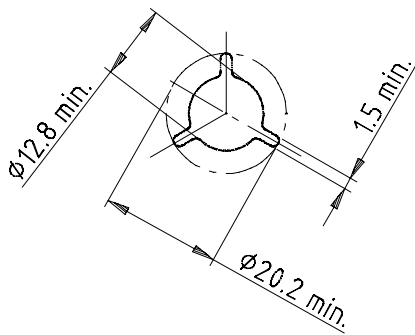
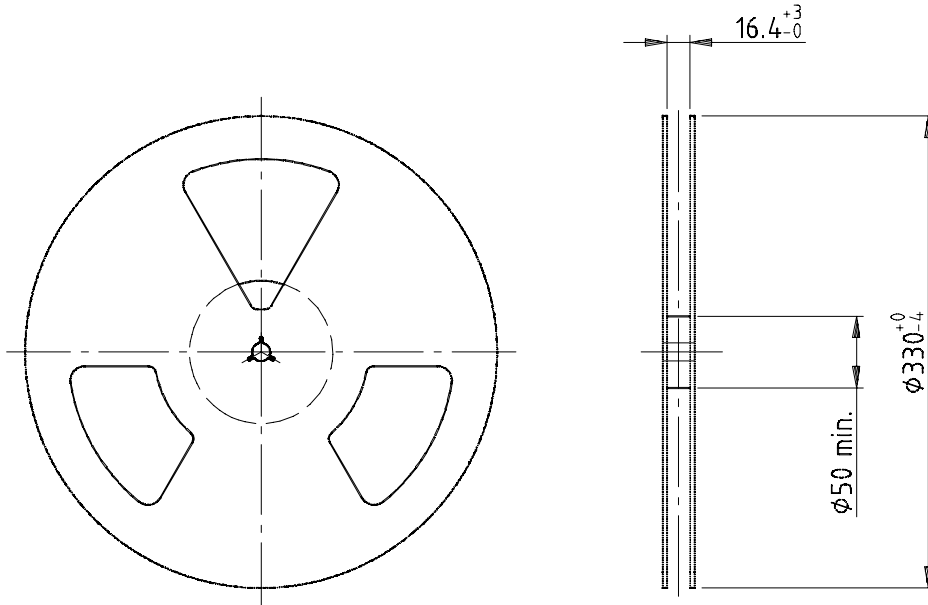

Reel hub 2:1

Form of the leave open of the wheel is supplier specific.

Dimension acc. to IEC EN 60 286-3

Tape width 16

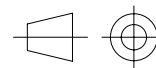

technical drawings according to DIN specifications

Drawing refers to following types: Reel for blister carrier tape Version B

Drawing-No.: 9.800-5052.V2-4

Issue: 1; 07.05.02

16734

**Leader and Trailer** Dimensions in millimeters

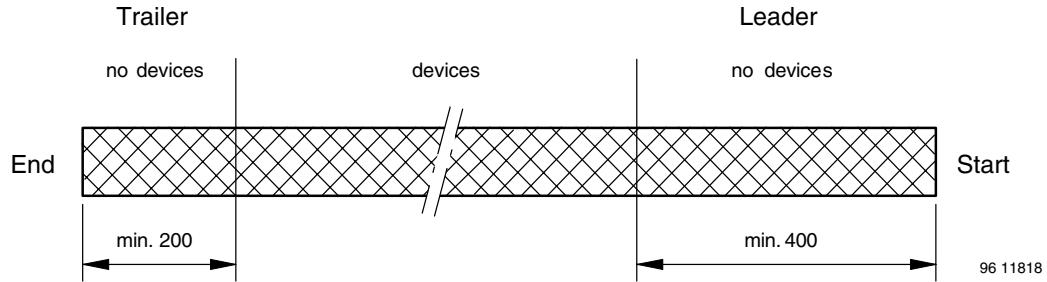

**Cover Tape Peel Strength**

According to DIN EN 60286-3

0.1 to 1.3 N

300 ± 10 mm/min

165° - 180° peel angle

**Label**

**Standard bar code labels for finished goods**

The standard bar code labels are product labels and used for identification of goods. The finished goods are packed in final packing area. The standard packing units are labeled with standard bar code labels before transported as finished goods to warehouses. The labels are on each packing unit and contain Vishay Semiconductor GmbH specific data.

Vishay Semiconductor GmbH standard bar code product label (finished goods)

Plain Writing	Abbreviation	Length
Item-Description	-	18
Item-Number	INO	8
Selection-Code	SEL	3
LOT-/Serial-Number	BATCH	10
Data-Code	COD	3 (YWW)
Plant-Code	PTC	2
Quantity	QTY	8
Accepted by:	ACC	-
Packed by:	PCK	-
Mixed Code Indicator	MIXED CODE	-
Origin	xxxxxxx <sup>+</sup>	Company Logo

Long Bar Code Top	Type	Length
Item-Number	N	8
Plant-Code	N	2
Sequence-Number	X	3
Quantity	N	8
Total Length	-	21

Short Bar Code Bottom	Type	Length
Selection-Code	X	3
Data-Code	N	3
Batch-Number	X	10
Filter	-	1
Total Length	-	17

16942

### Dry Packing

The reel is packed in an anti-humidity bag to protect the devices from absorbing moisture during transportation and storage.

### Final Packing

The sealed reel is packed into a cardboard box. A secondary cardboard box is used for shipping purposes.

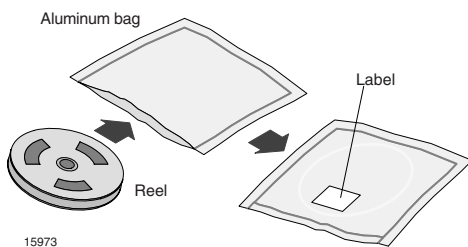

### Recommended Method of Storage

Dry box storage is recommended as soon as the aluminum bag has been opened to prevent moisture absorption. The following conditions should be observed, if dry boxes are not available:

- Storage temperature 10 °C to 30 °C
- Storage humidity ≤ 60 % RH max.

After more than 72 hours under these conditions moisture content will be too high for reflow soldering. In case of moisture absorption, the devices will recover to the former condition by drying under the following condition:

192 hours at 40 °C + 5 °C/ - 0 °C and < 5 % RH (dry air/nitrogen) or

96 hours at 60 °C + 5 °C and < 5 % RH for all device containers or

24 hours at 125 °C + 5 °C not suitable for reel or tubes.

An EIA JEDEC Standard JESD22-A112 Level 4 label is included on all dry bags.

### Vishay Semiconductors Standard Bar-Code Labels

The Vishay Semiconductors standard bar-code labels are printed at final packing areas. The labels are on each packing unit and contain Vishay Telefunken specific data.



16962

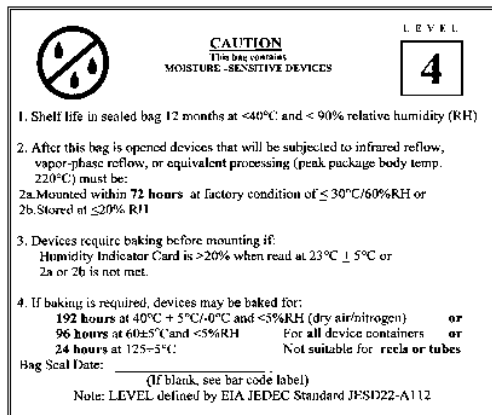

16943

Example of JESD22-A112 Level 4 label

### ESD Precaution

Proper storage and handling procedures should be followed to prevent ESD damage to the devices especially when they are removed from the Antistatic Shielding Bag. Electro-Static Sensitive Devices warning labels are on the packaging.

## Vishay Semiconductors

### Ozone Depleting Substances Policy Statement

It is the policy of Vishay Semiconductor GmbH to

1. Meet all present and future national and international statutory requirements.
2. Regularly and continuously improve the performance of our products, processes, distribution and operating systems with respect to their impact on the health and safety of our employees and the public, as well as their impact on the environment.

It is particular concern to control or eliminate releases of those substances into the atmosphere which are known as ozone depleting substances (ODSs).

The Montreal Protocol (1987) and its London Amendments (1990) intend to severely restrict the use of ODSs and forbid their use within the next ten years. Various national and international initiatives are pressing for an earlier ban on these substances.

Vishay Semiconductor GmbH has been able to use its policy of continuous improvements to eliminate the use of ODSs listed in the following documents.

1. Annex A, B and list of transitional substances of the Montreal Protocol and the London Amendments respectively
2. Class I and II ozone depleting substances in the Clean Air Act Amendments of 1990 by the Environmental Protection Agency (EPA) in the USA
3. Council Decision 88/540/EEC and 91/690/EEC Annex A, B and C (transitional substances) respectively.

Vishay Semiconductor GmbH can certify that our semiconductors are not manufactured with ozone depleting substances and do not contain such substances.

We reserve the right to make changes to improve technical design  
and may do so without further notice.

Parameters can vary in different applications. All operating parameters must be validated for each customer application by the customer. Should the buyer use Vishay Semiconductors products for any unintended or unauthorized application, the buyer shall indemnify Vishay Semiconductors against all claims, costs, damages, and expenses, arising out of, directly or indirectly, any claim of personal damage, injury or death associated with such unintended or unauthorized use.

Vishay Semiconductor GmbH, P.O.B. 3535, D-74025 Heilbronn, Germany



## Notice

Specifications of the products displayed herein are subject to change without notice. Vishay Intertechnology, Inc., or anyone on its behalf, assumes no responsibility or liability for any errors or inaccuracies.

Information contained herein is intended to provide a product description only. No license, express or implied, by estoppel or otherwise, to any intellectual property rights is granted by this document. Except as provided in Vishay's terms and conditions of sale for such products, Vishay assumes no liability whatsoever, and disclaims any express or implied warranty, relating to sale and/or use of Vishay products including liability or warranties relating to fitness for a particular purpose, merchantability, or infringement of any patent, copyright, or other intellectual property right.

The products shown herein are not designed for use in medical, life-saving, or life-sustaining applications. Customers using or selling these products for use in such applications do so at their own risk and agree to fully indemnify Vishay for any damages resulting from such improper use or sale.