

HA12187FP

Bus Interface Driver/Receiver IC

REJ03F0131-0200
(Previous: ADE-207-174A)
Rev.2.00
Jun 15, 2005

Description

The HA12187FP was developed to be used as a bus interface driver/receiver IC in automotive audio equipment controllers. It implements a two-wire serial bus.

Functions

- Two-input OR circuit
- Input comparator circuit
- Current output driver circuit
- Receiver input comparator circuit
- Receiver output circuit
- Standby circuit

Features

- Supports two data inputs (Pins 1 and 3 are the input pins)
- Comparators with hysteresis characteristics were adopted for the inputs
- Current drive output drivers adopted (Output current: 3.8 mA typical)
- Comparators with hysteresis characteristics were adopted for the receivers
- Wide receiver common-mode input operating range (Common-mode input operating range: 0 to 5 V typical)
- The driver output and the receiver input can withstand high voltages (Maximum rating: 18 V)
- Standby function (The IC enters standby mode when pin 8 goes low)
- Operating power-supply voltage range: 5 V \pm 0.5 V

Block Diagram

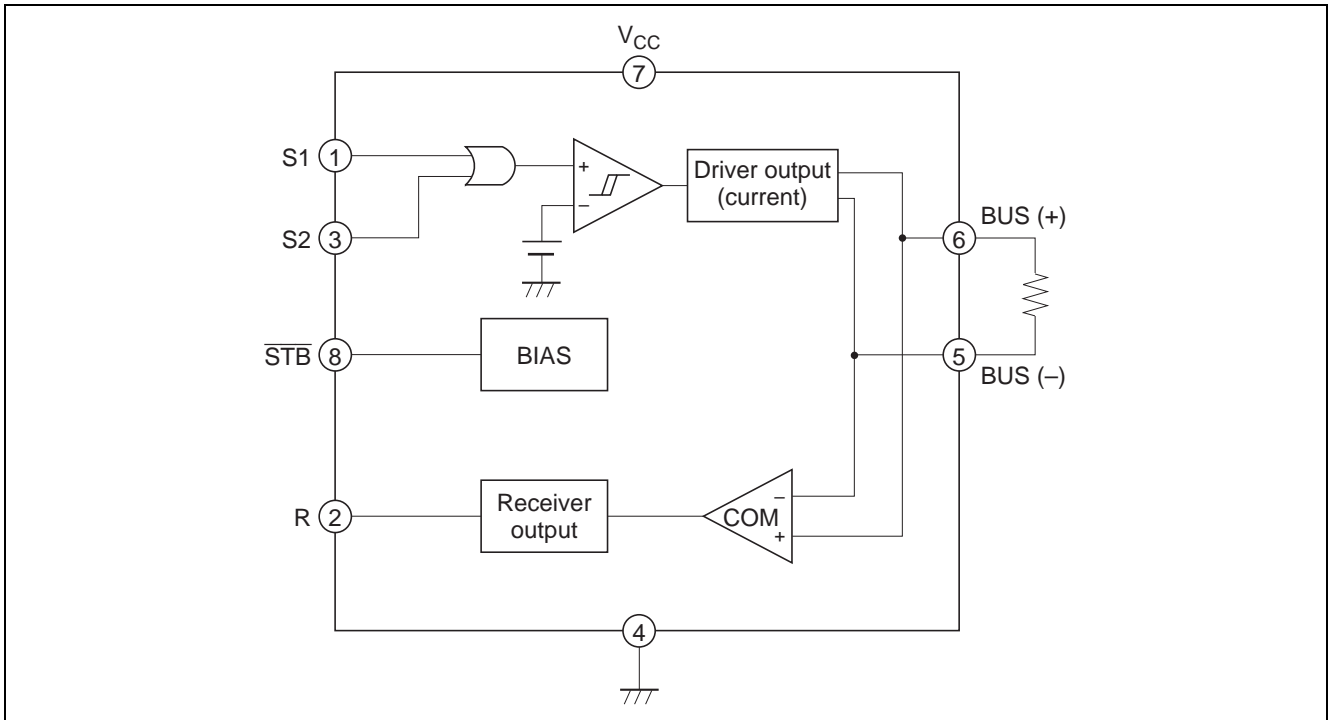

Pin Functions

Pin No.	Symbol	Function	Equivalent Circuit
1	S1	Data input	
2	R out	Receiver output	
3	S2	Data input	
4	GND	GND	
5	BUS (-)	Bus output (-) Receiver input (-)	
6	BUS (+)	Bus output (+) Receiver input (+)	
7	V _{CC}	Power supply	
8	STB	Standby control input	

Absolute Maximum Ratings

(Ta = 25°C)

Item	Symbol	Ratings	Unit	Notes
Power-supply voltage	V _{CC}	7	V	
Allowable power dissipation	P _d	400	mW	Ta ≤ 85°C
Operating temperature	T _{opr}	-40 to 85	°C	
Storage temperature	T _{stg}	-55 to 125	°C	
Input voltage	V _{in}	-1.0 to 6.7	V	
Bus input voltage	Bus	18	V	

Note: Recommended operating power supply voltage range: 5 V ±0.5 V

Electrical Characteristics

(V_{CC} = 5.0 V, Ta = 25°C)

Item		Symbol	Min	Typ	Max	Unit	Test Conditions	Test Pin	Test Circuit
S1	High-level input voltage	V _{IHS1}	3.5	—	—	V	V1 = 0 V → 5 V, V3 = 0 V With the potential difference between pin 5 and pin 6 120 mV or more	1	Figure 1
	Low-level input voltage	V _{ILS1}	—	—	1.5	V	V1 = 5 V → 0 V, V3 = 0 V With the potential difference between pin5 and pin 6 20 mV or less	1	
	High-level input current	I _{IHS1}	—	—	1	μA	V1 = 5 V, V3 = 0 V	1	
	Low-level input current	I _{ILS1}	—	—	1	μA	V1 = 0 V, V3 = 0 V	1	
S2	High-level input voltage	V _{IHS2}	3.5	—	—	V	V3 = 0 V → 5 V, V1 = 0 V With the potential difference between pin 5 and pin 6 120 mV or more	3	Figure 1
	Low-level input voltage	V _{ILS2}	—	—	1.5	V	V3 = 5 V → 0 V, V1 = 0 V With the potential difference between 5 and pin 6 20 mV or less	3	
	High-level input current	I _{IHS2}	—	—	1	μA	V1 = 0 V, V3 = 5 V	3	
	Low-level input current	I _{ILS2}	—	—	1	μA	V1 = 0 V, V3 = 0 V	3	
Driver	High-level output current	I _{OH}	3.0	3.8	4.8	mA	I _{OH} = V _{OHD+} - V _{OHD-} / 62 Ω	5, 6	Figure 1
	Low-level output leakage current	I _{OL}	—	—	1	μA	Pin 5 voltage = V _{OP-} I _{OL} = V _{OP+} - V _{OP-} / R _I	5, 6	
	Reference operating voltage (+)	V _{OP+}	2.3	2.5	2.7	V	V1 = 0 V, V3 = 0 V	6	
	Reference operating voltage (-)	V _{OP-}	2.3	2.5	2.7	V	V1 = 0 V, V3 = 0 V	5	
Current drain 1	I _{CCH}	5.5	7.3	9.5	mA	V1 = 5 V, V3 = 0 V	7	Figure 1	
Current drain 2	I _{CCL}	1.7	2.2	2.7	mA	V1 = 0 V, V3 = 0 V	7	Figure 1	

Electrical Characteristics (cont.)

(V_{CC} = 5.0 V, Ta = 25°C)

Item		Symbol	Min	Typ	Max	Unit	Test Condition	Test Pin	Test Circuit
Receiver	High-level input voltage (1)	V _{IH1}	—	80	120	mV	V ₆ = 0 → 5 V, pin 2 = 4 V or more, V ₁ = 0 V, V ₃ = 0 V, V ₅ = V _{OP-} , V _{IH1} = V ₆ - V ₅	2	Figure 2
	Low-level input voltage (1)	V _{IL1}	20	45	—	mV	V ₆ = 5 → 0 V, pin 2 = 1 V or less, V ₁ = 0 V, V ₃ = 0 V, V ₅ = V _{OP-} , V _{IL1} = V ₆ - V ₅	2	Figure 2
	Input hysteresis voltage (1)	V _{IHYS1}	10	35	60	mV	V _{IHYS1} = V _{IH1} - V _{IL1}		
	High-level common-mode input voltage	V _{IHCOM}	4.5	—	—	V	V ₅ = 0 → 5 V, pin 2 = 4 V or more, V ₁ = 0 V, V ₃ = 0 V, V ₆ - V ₅ = 120 mV	5	Figure 2
	Low-level common-mode input voltage	V _{ILCOM}	5	—	—	V	V ₅ = 0 → 5 V, pin 2 = 1 V or less, V ₁ = 0 V, V ₃ = 0 V, V ₆ - V ₅ = 20 mV	5	Figure 2
	Receiver input resistance* ¹	R _I	25	35	45	kΩ	V ₁ = 0 V, $R_I = \frac{0.6V}{I_1 - I_2}$	5, 6	Figure 3
	High-level output voltage	V _{OH}	4.5	—	—	V	V ₁ = 5 V, V ₃ = 0 V	2	Figure 1
	Low-level output voltage	V _{OL}	—	—	1.0	V	V ₁ = 0 V, V ₃ = 0 V	2	Figure 1
Power supply off output leakage current	I _{OLEAK}	—	—	1	μA	V _{CC} off, V ₈ = 0 V, V ₆ = 5 V, V ₁ = 0 V, V ₃ = 0 V, SW1 on	5, 6	Figure 4	
STB on voltage	V _{STBon}	—	—	1.5	V	V ₈ = 5 → 0 V, V ₁ = 5 V, V ₈ when I _{CC} ≤ 20 μA	7	Figure 4	
STB off voltage	V _{STBoff}	3.5	—	—	V	V ₈ = 0 → 5 V, V ₁ = 5 V, V ₈ when I _{CC} ≥ 4.5 mA	7	Figure 4	
Standby mode current drain	I _{CCstb}	—	10	20	μA	V ₁ = 5 V, V ₃ = 0 V, V ₈ = 0 V	7	Figure 4	
Standby mode leakage current	I _{stb-Leak}	—	—	1	μA	V ₁ = 5 V, V ₃ = 0 V, V ₈ = 0 V, V ₆ = 5 V, SW1 on	5, 6	Figure 4	
Delay time (L → H)	DLY1	—	600	800	nS	See the operating waveform figure	2	Figure 5	
Delay time (H → L)	DLY2	—	450	800	nS	See the operating waveform figure	2	Figure 5	

Note: 1. I₁ is the measured current when V₆ = (V_{OP+}) + 0.3 V, and I₂ is the measured current when V₆ = (V_{OP+}) - 0.3 V.

Test Circuits

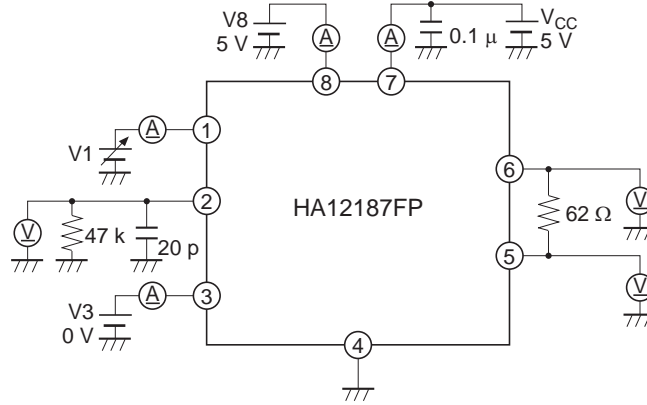

Test Circuit 1

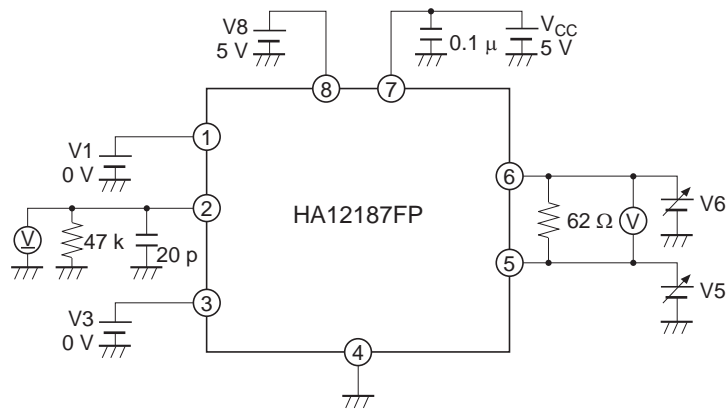

Test Circuit 2

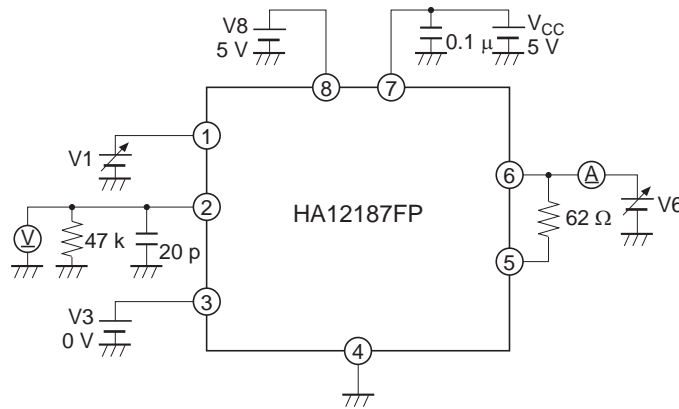

Test Circuit 3

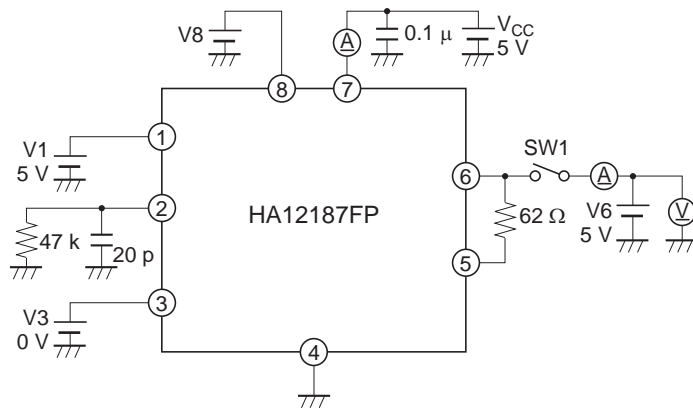

Test Circuit 4

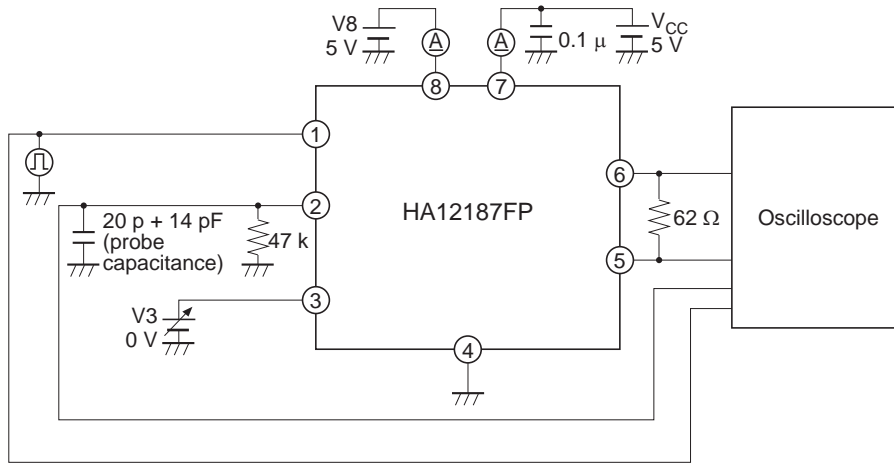

Test Circuit 5

Operating Waveforms

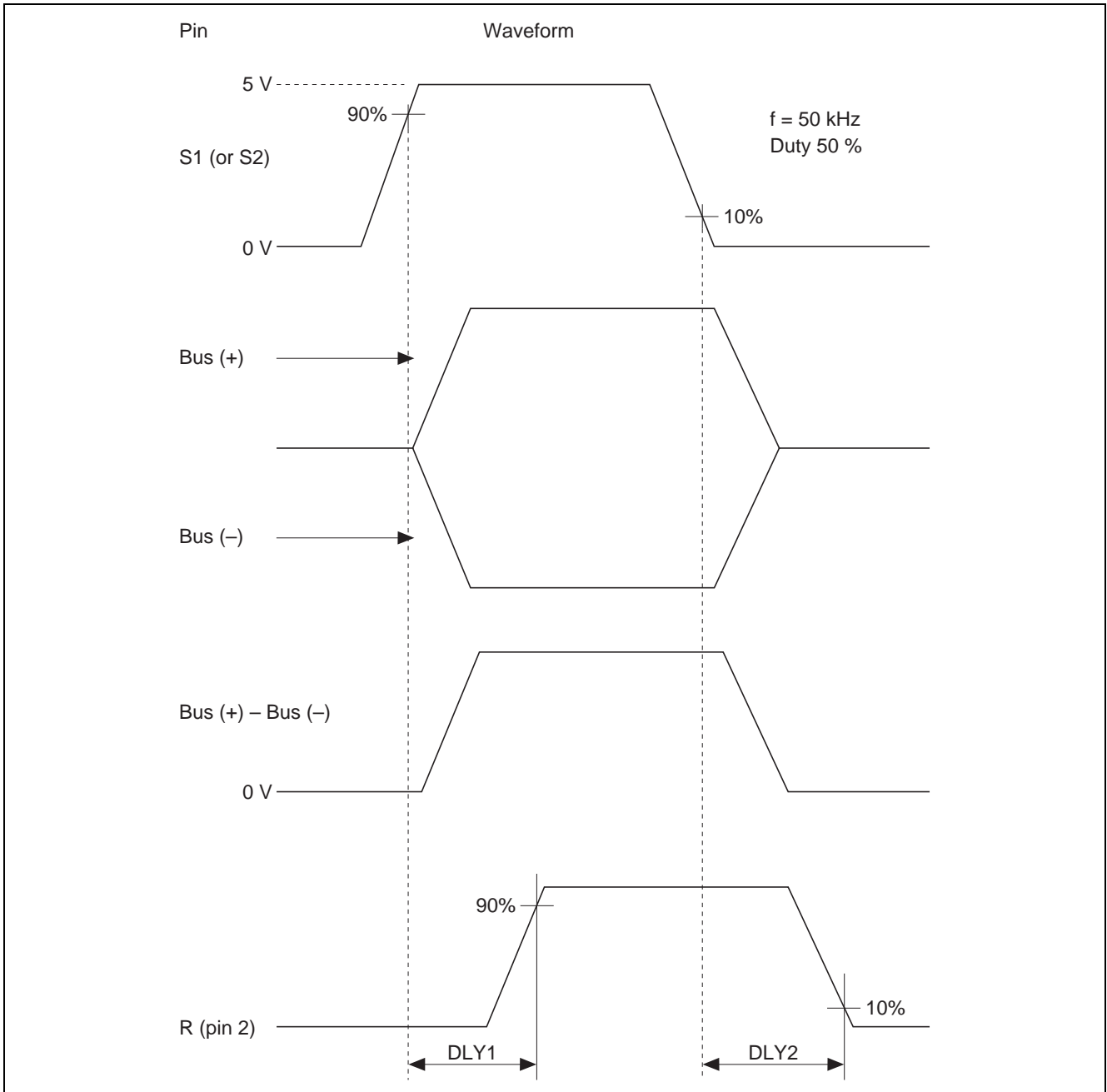

Main Characteristics

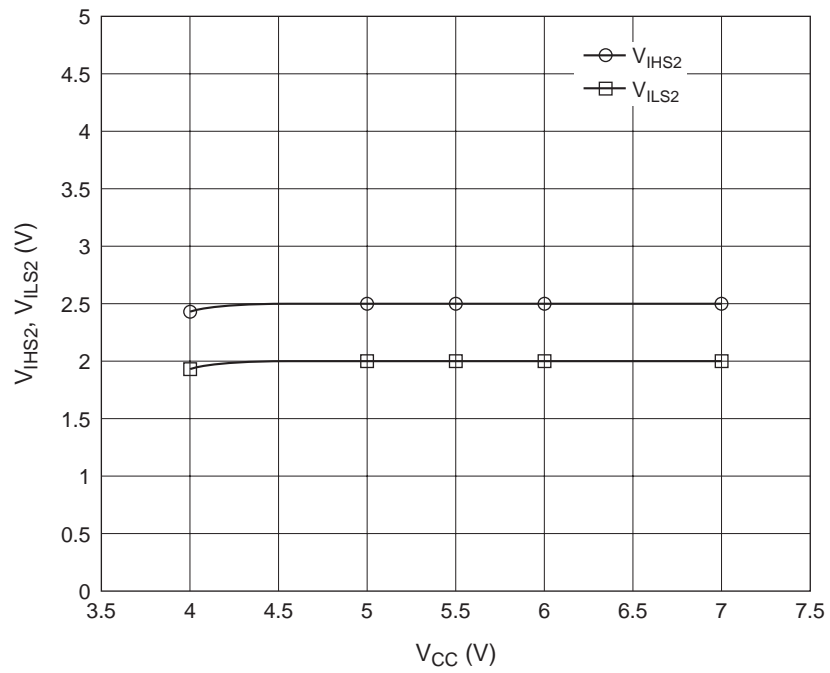
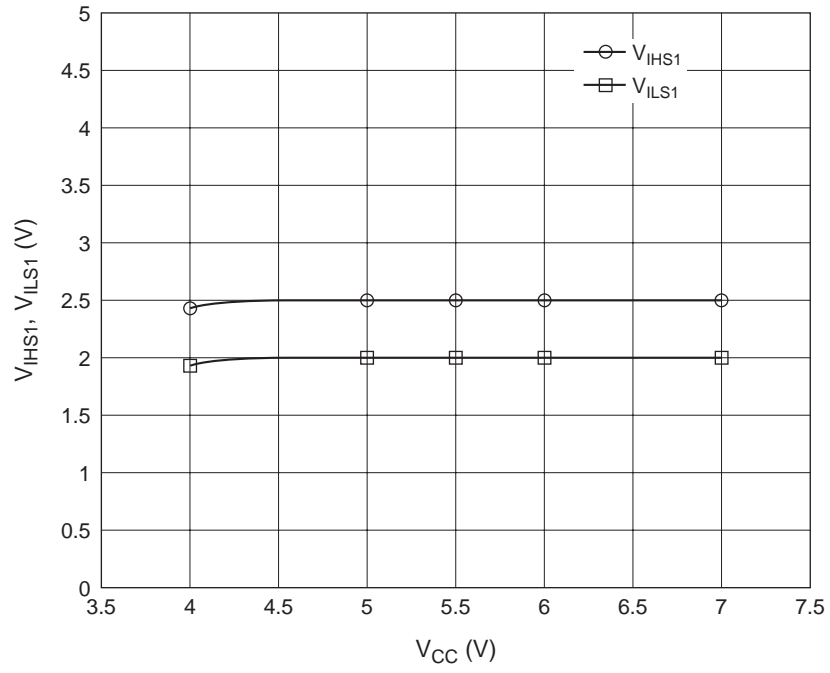

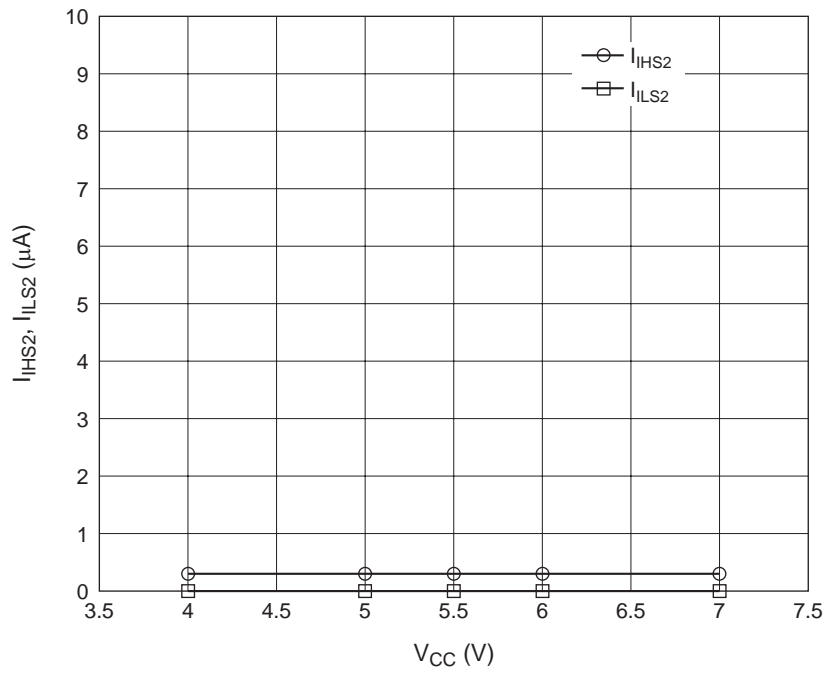
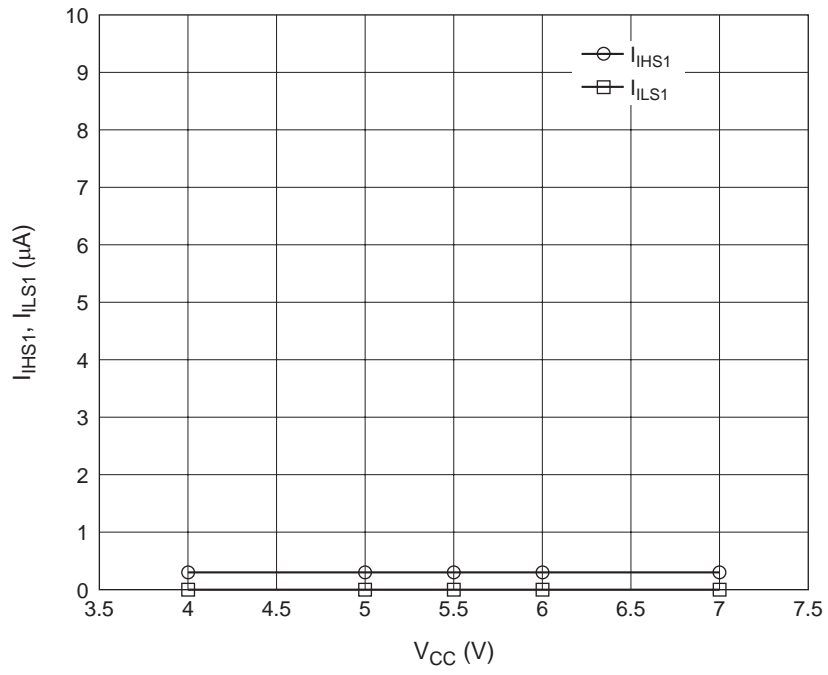

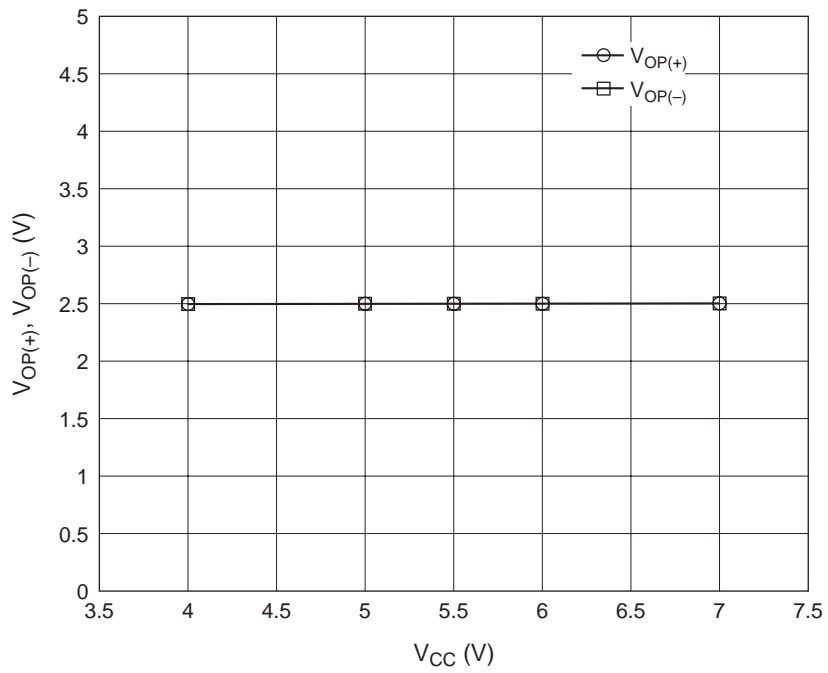
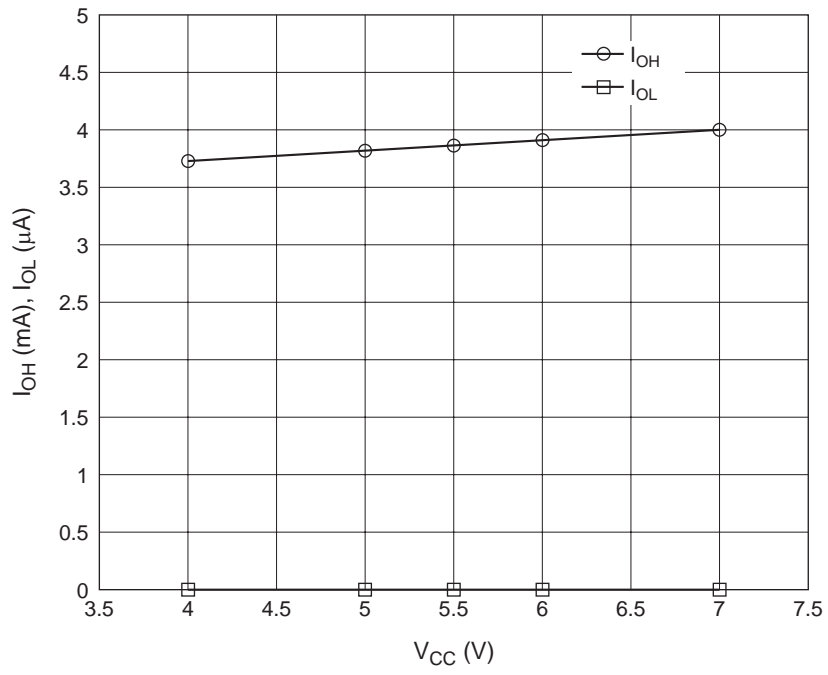

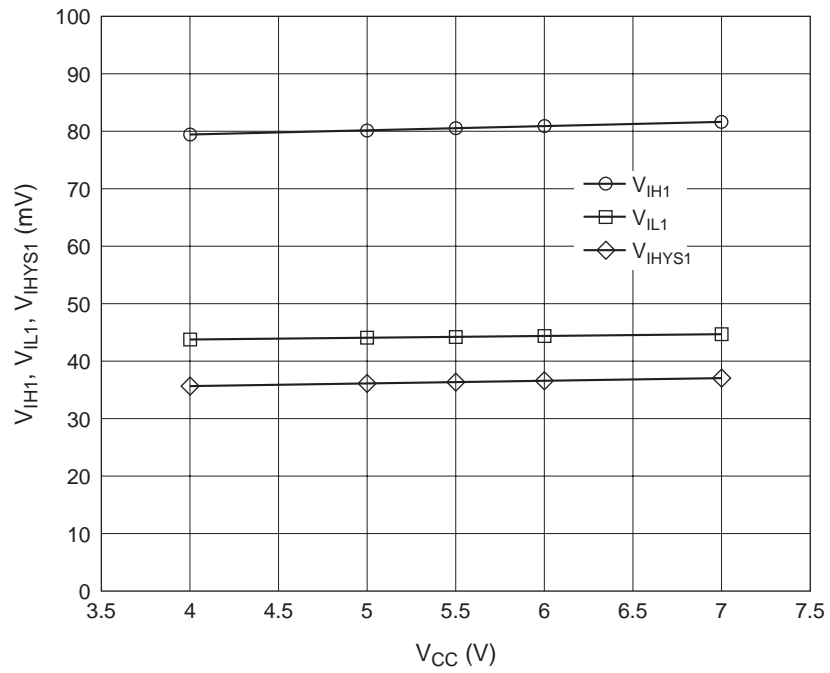
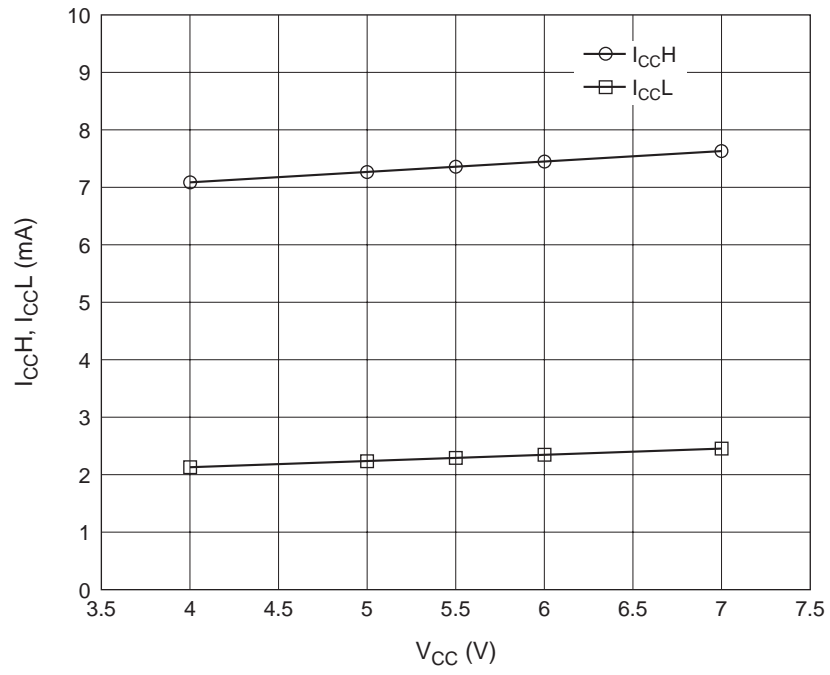

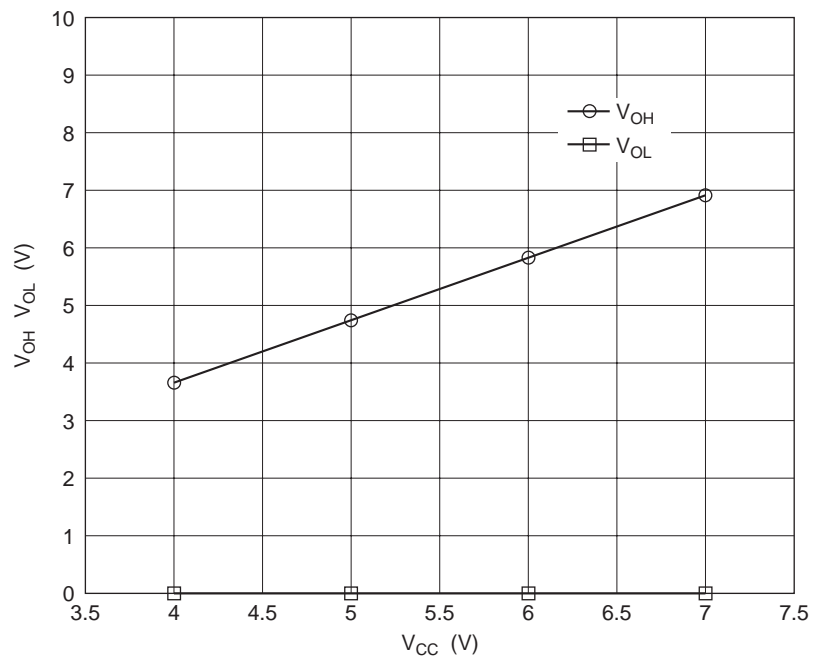
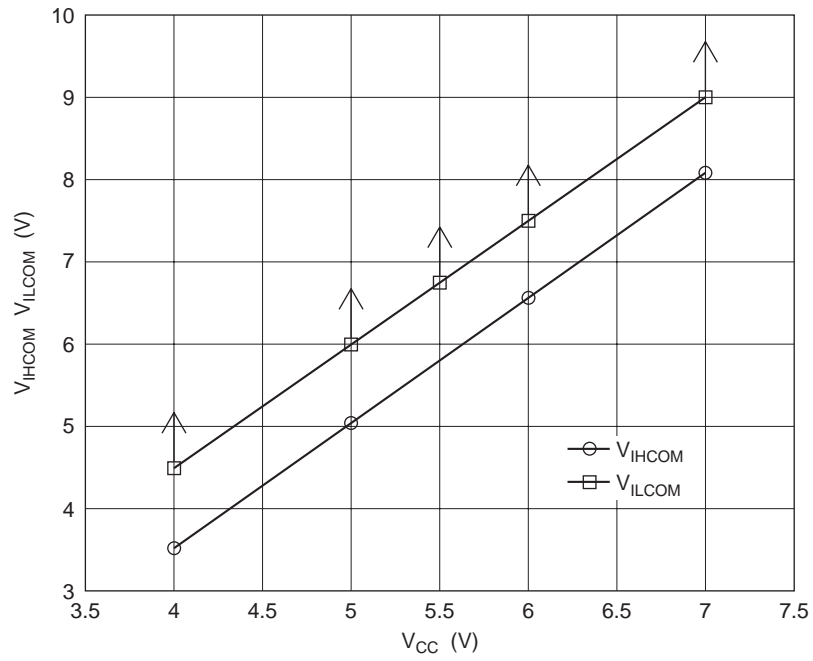

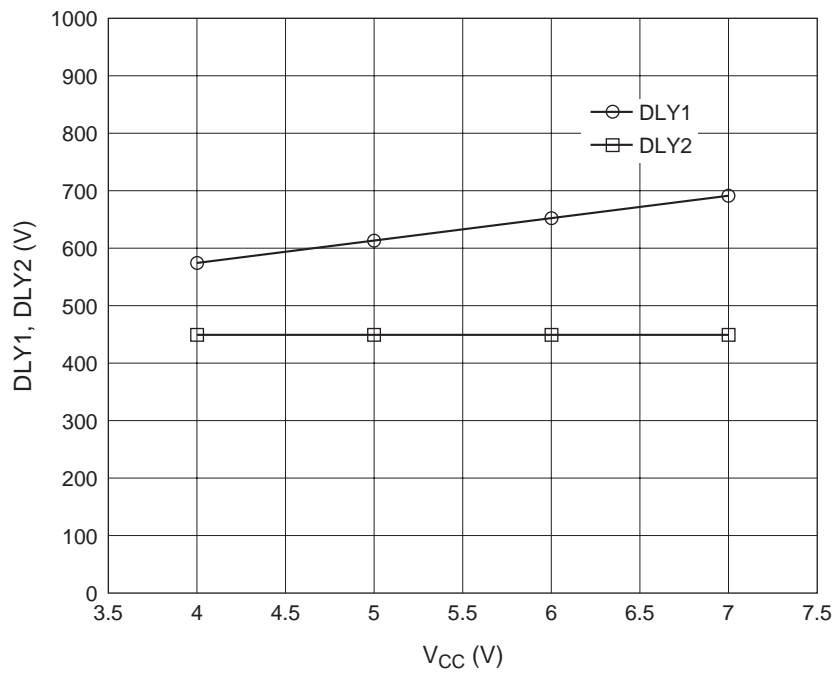
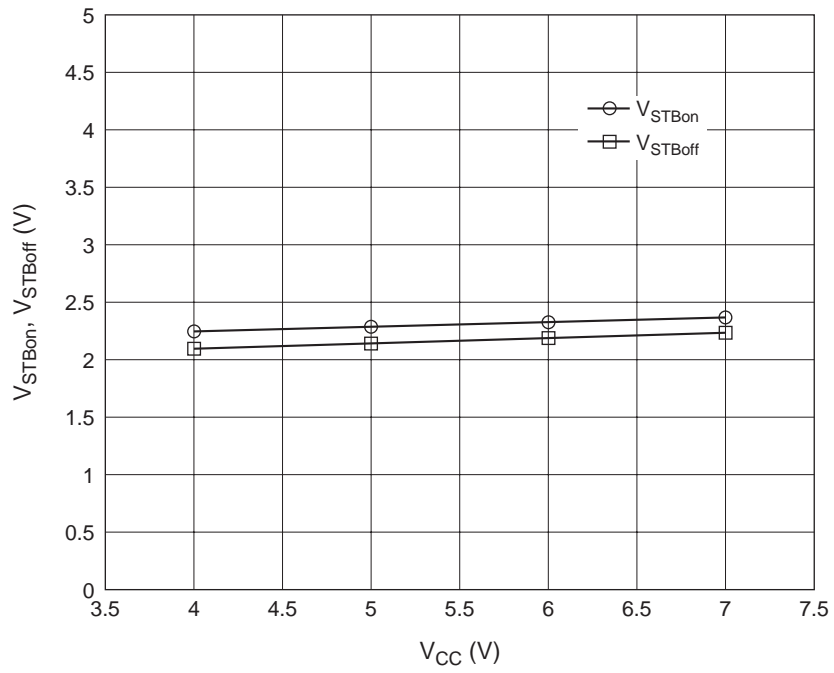

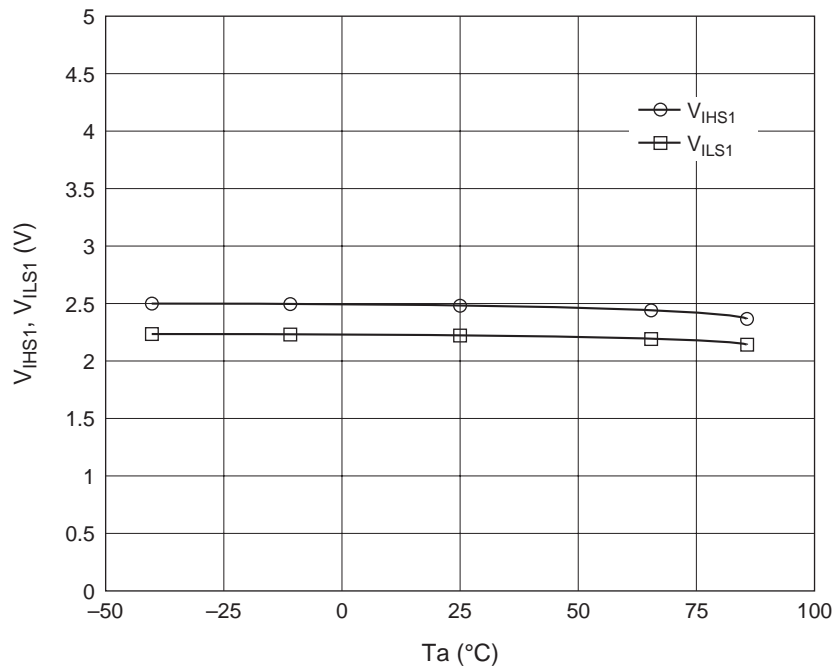
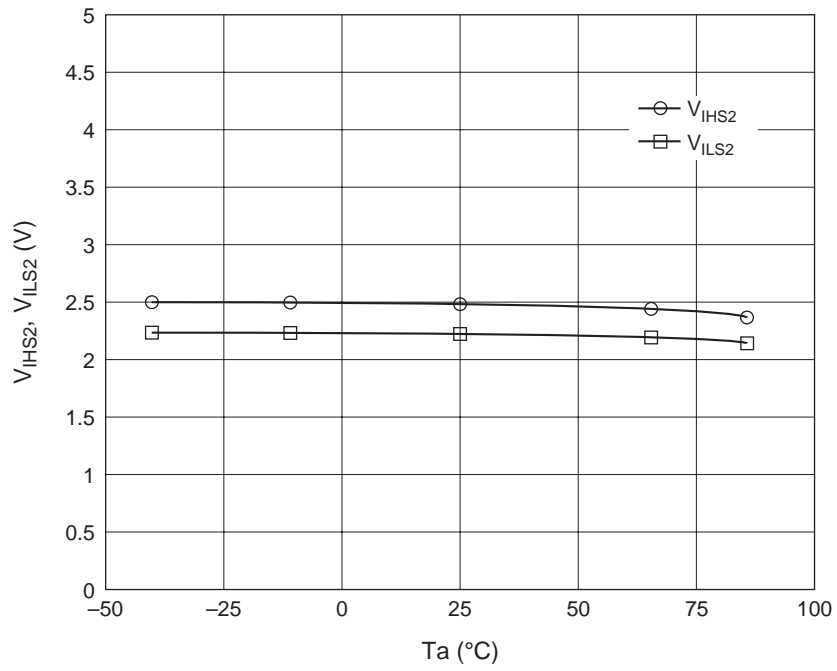

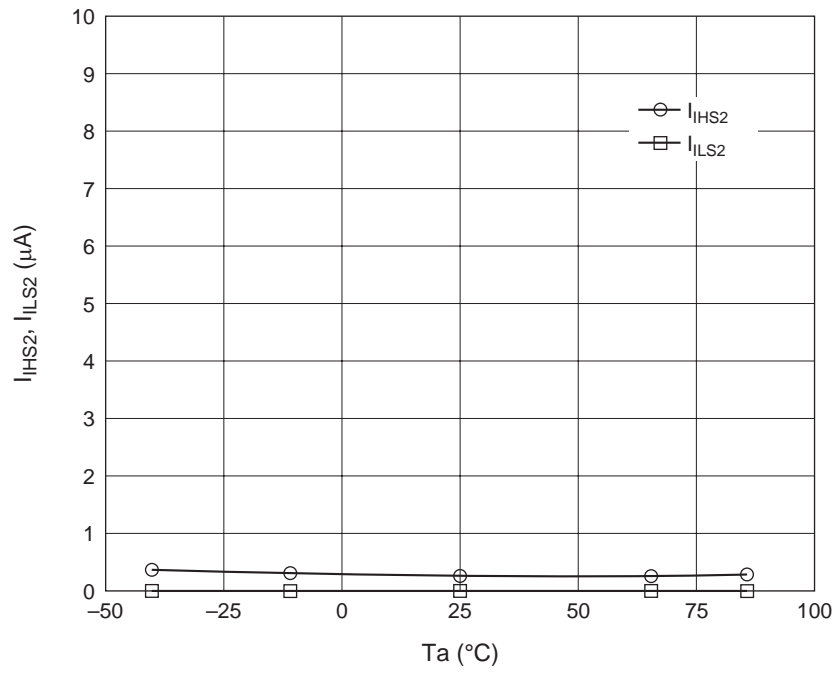
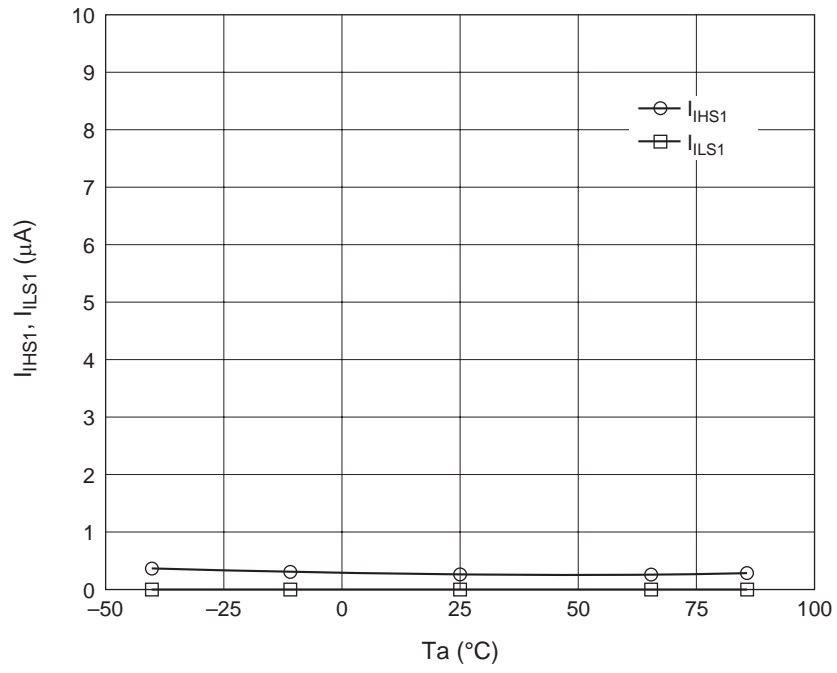

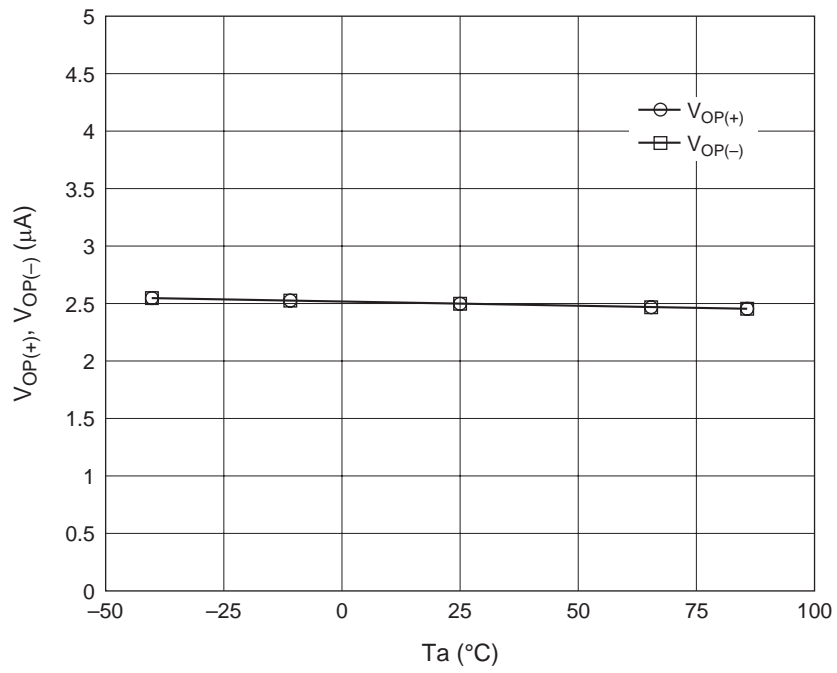
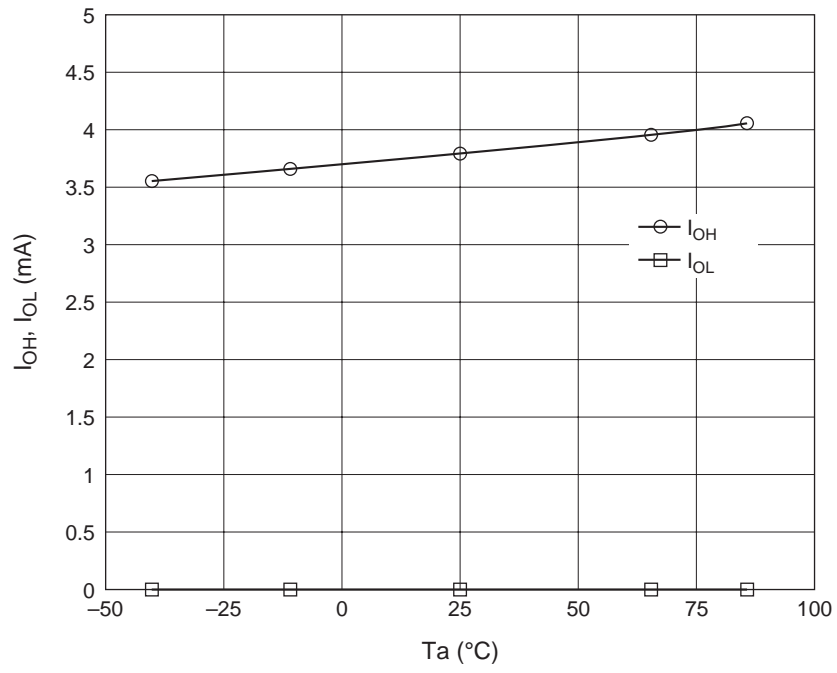

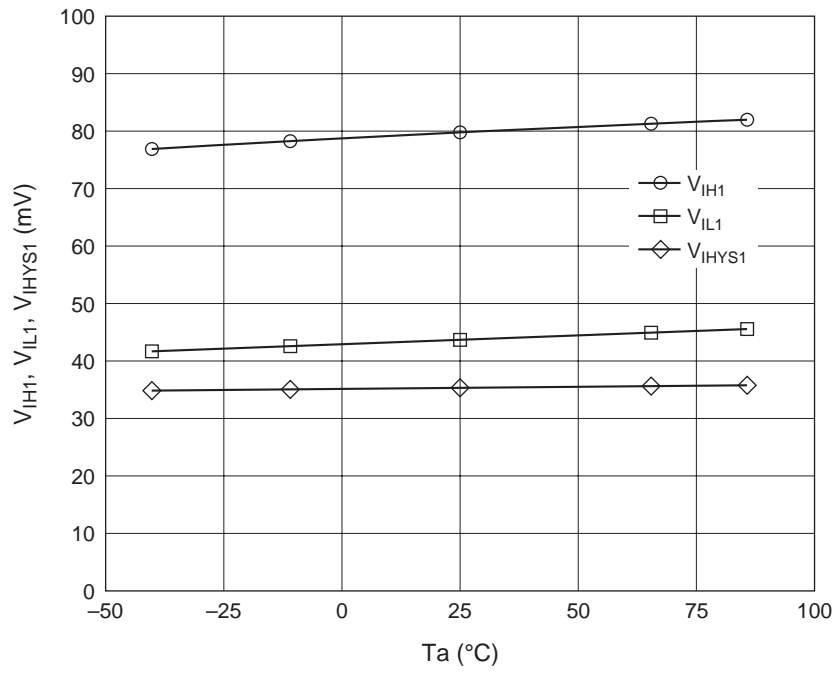
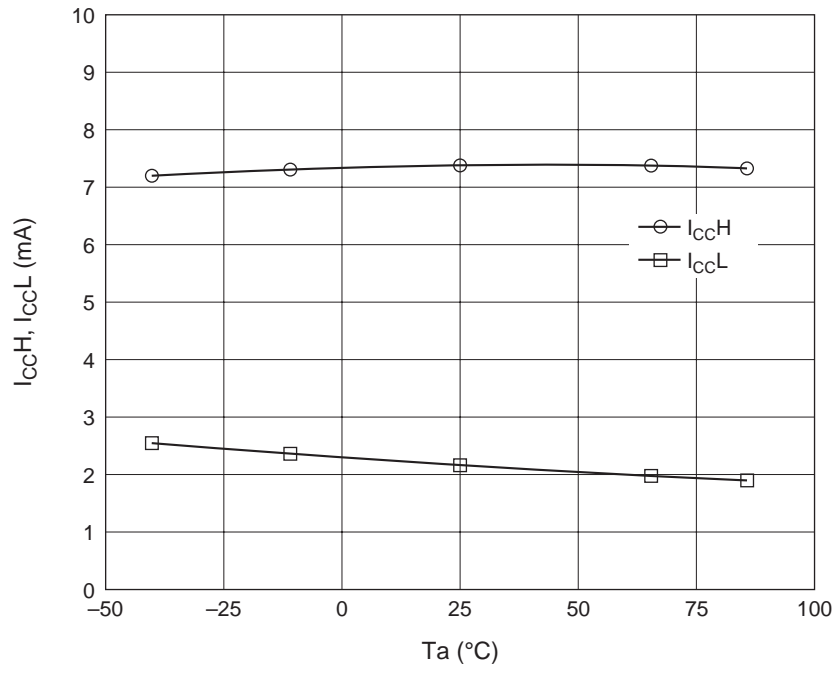

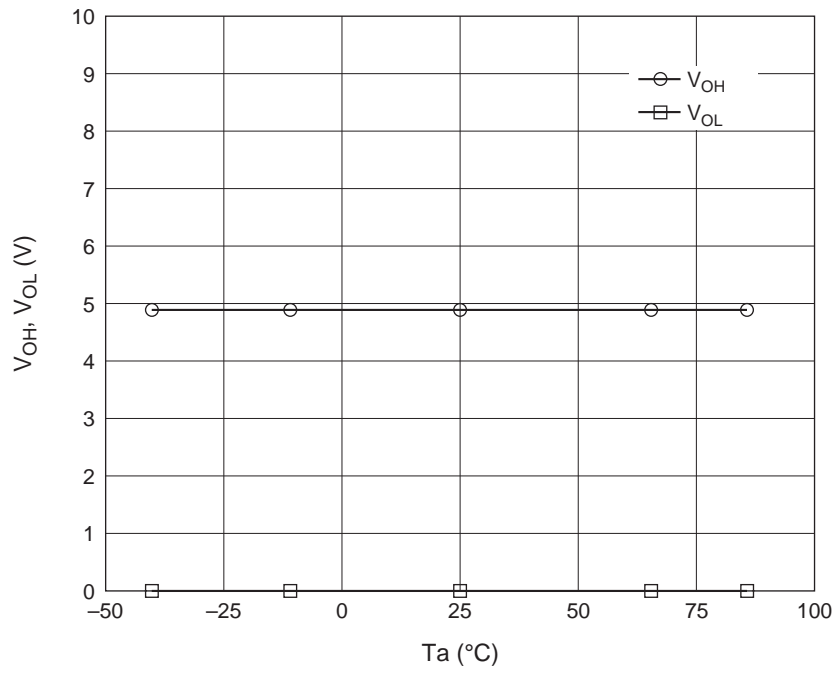
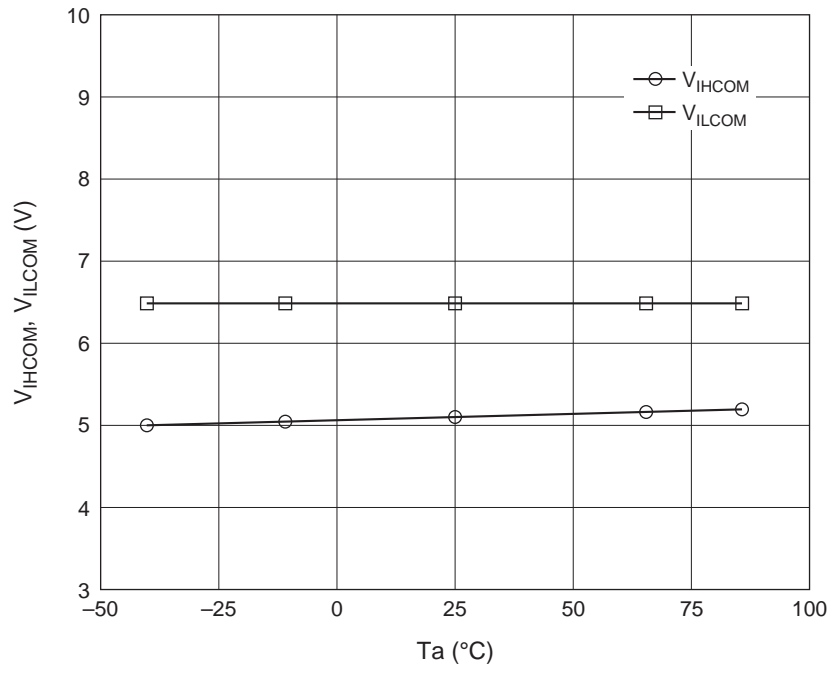

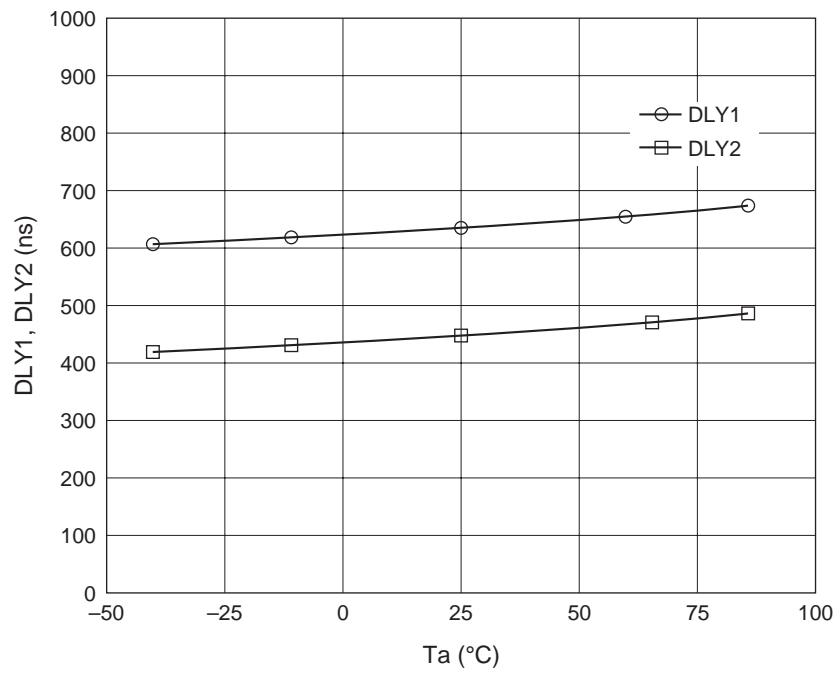
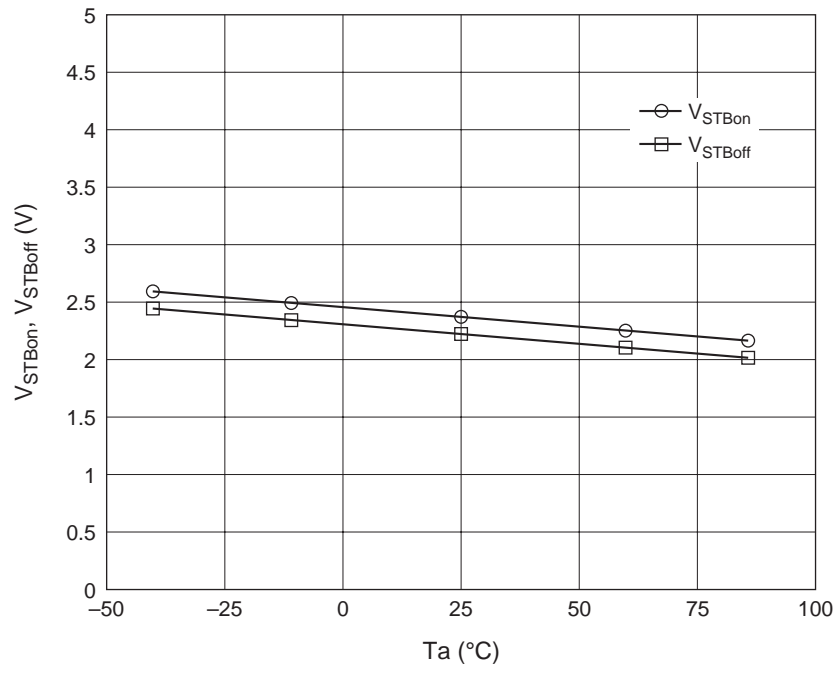

Package Dimensions

JEITA Package Code	RENESAS Code	Previous Code	MASS[Typ.]
P-SOP8-4.4x4.85-1.27	PRSP0008DE-A	FP-8D	0.1g

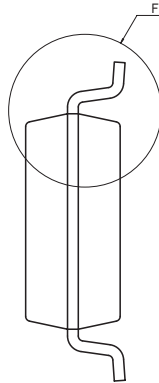
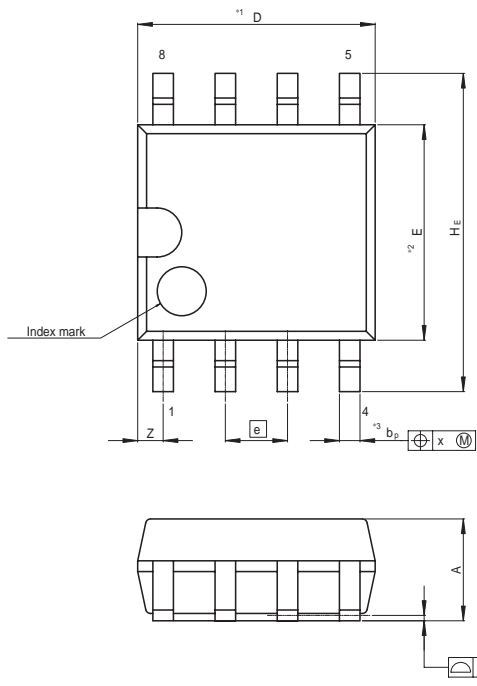

NOTE)
 1. DIMENSIONS* 1 (Nom)*AND* 2
 DO NOT INCLUDE MOLD FLASH.
 2. DIMENSION* 3 *DOES NOT
 INCLUDE TRIM OFFSET.

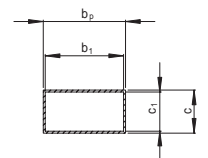

Terminal cross section

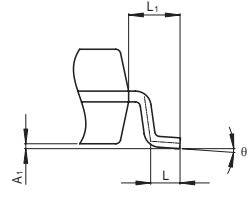

Detail F

Reference Symbol	Dimension in Millimeters		
	Min	Nom	Max
D	—	4.85	5.25
E	—	4.4	—
A ₂	—	—	—
A ₁	0.00	0.10	0.20
A	—	—	2.03
b _p	0.34	0.42	0.50
b ₁	—	0.40	—
c	0.17	0.22	0.27
c ₁	—	0.20	—
θ	0°	—	8°
H _E	6.35	6.50	6.75
e	—	1.27	—
x	—	—	0.12
y	—	—	0.15
Z	—	—	0.75
L	0.42	0.60	0.85
L ₁	—	1.05	—

Renesas Technology Corp. Sales Strategic Planning Div. Nippon Bldg., 2-6-2, Ohte-machi, Chiyoda-ku, Tokyo 100-0004, Japan

Keep safety first in your circuit designs!

1. Renesas Technology Corp. puts the maximum effort into making semiconductor products better and more reliable, but there is always the possibility that trouble may occur with them. Trouble with semiconductors may lead to personal injury, fire or property damage.
Remember to give due consideration to safety when making your circuit designs, with appropriate measures such as (i) placement of substitutive, auxiliary circuits, (ii) use of nonflammable material or (iii) prevention against any malfunction or mishap.

Notes regarding these materials

1. These materials are intended as a reference to assist our customers in the selection of the Renesas Technology Corp. product best suited to the customer's application; they do not convey any license under any intellectual property rights, or any other rights, belonging to Renesas Technology Corp. or a third party.
 2. Renesas Technology Corp. assumes no responsibility for any damage, or infringement of any third-party's rights, originating in the use of any product data, diagrams, charts, programs, algorithms, or circuit application examples contained in these materials.
 3. All information contained in these materials, including product data, diagrams, charts, programs and algorithms represents information on products at the time of publication of these materials, and are subject to change by Renesas Technology Corp. without notice due to product improvements or other reasons. It is therefore recommended that customers contact Renesas Technology Corp. or an authorized Renesas Technology Corp. product distributor for the latest product information before purchasing a product listed herein.
The information described here may contain technical inaccuracies or typographical errors.
Renesas Technology Corp. assumes no responsibility for any damage, liability, or other loss rising from these inaccuracies or errors.
Please also pay attention to information published by Renesas Technology Corp. by various means, including the Renesas Technology Corp. Semiconductor home page (<http://www.renesas.com>).
 4. When using any or all of the information contained in these materials, including product data, diagrams, charts, programs, and algorithms, please be sure to evaluate all information as a total system before making a final decision on the applicability of the information and products. Renesas Technology Corp. assumes no responsibility for any damage, liability or other loss resulting from the information contained herein.
 5. Renesas Technology Corp. semiconductors are not designed or manufactured for use in a device or system that is used under circumstances in which human life is potentially at stake. Please contact Renesas Technology Corp. or an authorized Renesas Technology Corp. product distributor when considering the use of a product contained herein for any specific purposes, such as apparatus or systems for transportation, vehicular, medical, aerospace, nuclear, or undersea repeater use.
 6. The prior written approval of Renesas Technology Corp. is necessary to reprint or reproduce in whole or in part these materials.
 7. If these products or technologies are subject to the Japanese export control restrictions, they must be exported under a license from the Japanese government and cannot be imported into a country other than the approved destination.
Any diversion or reexport contrary to the export control laws and regulations of Japan and/or the country of destination is prohibited.
 8. Please contact Renesas Technology Corp. for further details on these materials or the products contained therein.
-



RENESAS SALES OFFICES

<http://www.renesas.com>

Refer to "<http://www.renesas.com/en/network>" for the latest and detailed information.

Renesas Technology America, Inc.

450 Holger Way, San Jose, CA 95134-1368, U.S.A
Tel: <1> (408) 382-7500, Fax: <1> (408) 382-7501

Renesas Technology Europe Limited

Dukes Meadow, Millboard Road, Bourne End, Buckinghamshire, SL8 5FH, U.K.
Tel: <44> (1628) 585-100, Fax: <44> (1628) 585-900

Renesas Technology Hong Kong Ltd.

7th Floor, North Tower, World Finance Centre, Harbour City, 1 Canton Road, Tsimshatsui, Kowloon, Hong Kong
Tel: <852> 2265-6688, Fax: <852> 2730-6071

Renesas Technology Taiwan Co., Ltd.

10th Floor, No.99, Fushing North Road, Taipei, Taiwan
Tel: <886> (2) 2715-2888, Fax: <886> (2) 2713-2999

Renesas Technology (Shanghai) Co., Ltd.

Unit2607 Ruijing Building, No.205 Maoming Road (S), Shanghai 200020, China
Tel: <86> (21) 6472-1001, Fax: <86> (21) 6415-2952

Renesas Technology Singapore Pte. Ltd.

1 Harbour Front Avenue, #06-10, Keppel Bay Tower, Singapore 098632
Tel: <65> 6213-0200, Fax: <65> 6278-8001