

Wall Industries, Inc.

CMMDW48S3.3-5500

18W DC/DC Chassis Mount Converter
18-75 VDC Input
3.3 VDC Single Output at 5500mA

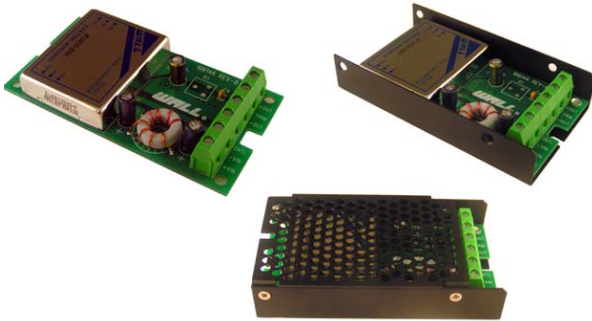

UL
TUV
CB
CE MARK (Pending)

Applications:

- Computer Equipment
- Communications Equipment
- Distributed Power Architectures

Options:

- Negative Remote ON/OFF
- Heatsinks Available for Extended Operation
- Open Frame, U Chassis, and Enclosed Types

Features:

- RoHS Directive Compliant
- 5.5A Single Output Current
- No Minimum Load Requirement
- 18 Watts Output Power
- Adjustable Output Voltage
- High Efficiency up to 85%
- Dimensions: 4.00(L) x 2.25(W) x 0.81(H) Inches
- Input to Output Isolation: 1600VDC min
- 4:1 Ultra Wide Input Voltage Range
- Fixed Switching Frequency
- Input Under Voltage Protection
- Output Over Voltage Protection
- Over Current Protection, Auto-Recovery
- Output Short Circuit Protection
- Remote ON/OFF Control

Description:

The CMMDW48S3.3-5500 is a single output DC/DC converter on a chassis mount that provides 18 watts of output power. The CMMDW48S3.3-5500 features a 4:1 wide input voltage range of 18-75VDC as well as positive or negative remote on/off, 1600VDC I/O isolation, and trimmable output voltage. This converter is also protected against over current, over voltage, input under voltage, and short circuit conditions. The CMMDW48S3.3-5500 is particularly suited for telecommunications, industrial, mobile telecom, and test equipment applications.

Technical Specifications		Model No.	CMMDW48S3.3-5500			
All specifications are based on 25°C, Nominal Input Voltage, and Maximum Output Current unless otherwise noted. We reserve the right to change specifications based on technological advances.						
SPECIFICATION	Related condition	Min	Nom	Max	Unit	
INPUT (V_{in})						
Operating Voltage Range		18	48	75	Vdc	
UVLO Turn-on Threshold			18		Vdc	
UVLO Turn-off Threshold			15		Vdc	
Input Standby Current	Nominal Vin and No Load		35		mA	
Input Current	Nominal Vin and Full Load			467	mA	
Input Voltage	Continuous			75	Vdc	
	Transient (100ms)			100		
Input Voltage Variation	Complies with ETS300 132 part 4.4			5	V/ms	
Reflected Ripple Current	5 to 20MHz, 12µH source impedance (See the Test Setup section - pg 9)		20		mA _{pk-pk}	
Start Up Time (Nominal Vin and constant resistive load)	Power Up			20	ms	
	Remote On/Off			20		
OUTPUT (V_o)						
Output Voltage Range	Nominal Vin and Full Load; Ta = 25°C	3.267	3.3	3.333	Vdc	
Load Regulation	0% to 100% Full Load	-0.5		+0.5	%	
Line Regulation	LL to HL at Full Load	-0.2		+0.2	%	
Voltage Adjustability (see page 6)		-10		+10	%	
Output Ripple & Noise (20MHz)	Measured with a 0.1µF/50V MLCC (See the Test Setup section - pg 9)		60		mV _{pk-pk}	
Output Current		0		5500	mA	
Output Voltage Overshoot	LL to HL at Full Load and 25°C		0	5	% Vout	
PROTECTION						
Over Voltage Protection	Zener diode clamp		3.9		Vdc	
Over Current Protection			150		% FL	
Short Circuit Protection		Hiccup, automatic-recovery				
DYNAMIC LOAD RESPONSE						
Test at nominal Vin and 25°C						
Peak Deviation	Load step change from 75 to 100% or 100 to 75 % of FL		200		mV	
Setting Time (Vout < 10% peak deviation)	Load step change from 75 to 100% or 100 to 75 % of FL		250		µs	
REMOTE ON/OFF						
The ON/OFF pin voltage is referenced to -Vin (See the Remote ON/OFF Control section - pg 7)						
Negative Logic (Option)	DC/DC ON	0		1.2	Vdc	
	DC/DC OFF	3		12		
Positive Logic (Standard)	DC/DC ON	3		12	Vdc	
	DC/DC OFF	0		1.2		
Remote OFF Input Current			2.5		mA	
Input Current of Remote Control Pin		-0.5		0.5	mA	
GENERAL						
Switching Frequency			400		KHz	
Efficiency	Nominal Vin, and full load; Ta=25°C (See the Test Setup section - pg 9)		85		%	
ISOLATION						
Isolation Voltage (Input-Output)		1600			Vdc	
Isolation Voltage (Output to Case)		1600			Vdc	
Isolation Voltage (Input to Case)		1600			Vdc	
Isolation Resistance		1			GΩ	
Isolation Capacitance				1500	pF	
ENVIRONMENTAL						
Operating Ambient Temperature (with derating)		-40		105	°C	
Operating Case Temperature				105	°C	
Storage Temperature		-55		125	°C	
Temperature Coefficient		-0.02		+0.02	% / °C	
MTBF						
See the MTBF and Reliability section (pg 10)						
Bellcore TR-NWT-000332, T _c =40°C			1,621,000		hours	
MIL-HDBK-217F			659,000		hours	
MECHANICAL						
See Figure 1						
Weight		6 oz				
Dimensions		4.00(L) x 2.25(W) x 0.81(H) inches 101.6(L) x 57.2(W) x 20.6(H) mm				

Figure 1: Mechanical Dimensions

Unit: inches (mm)

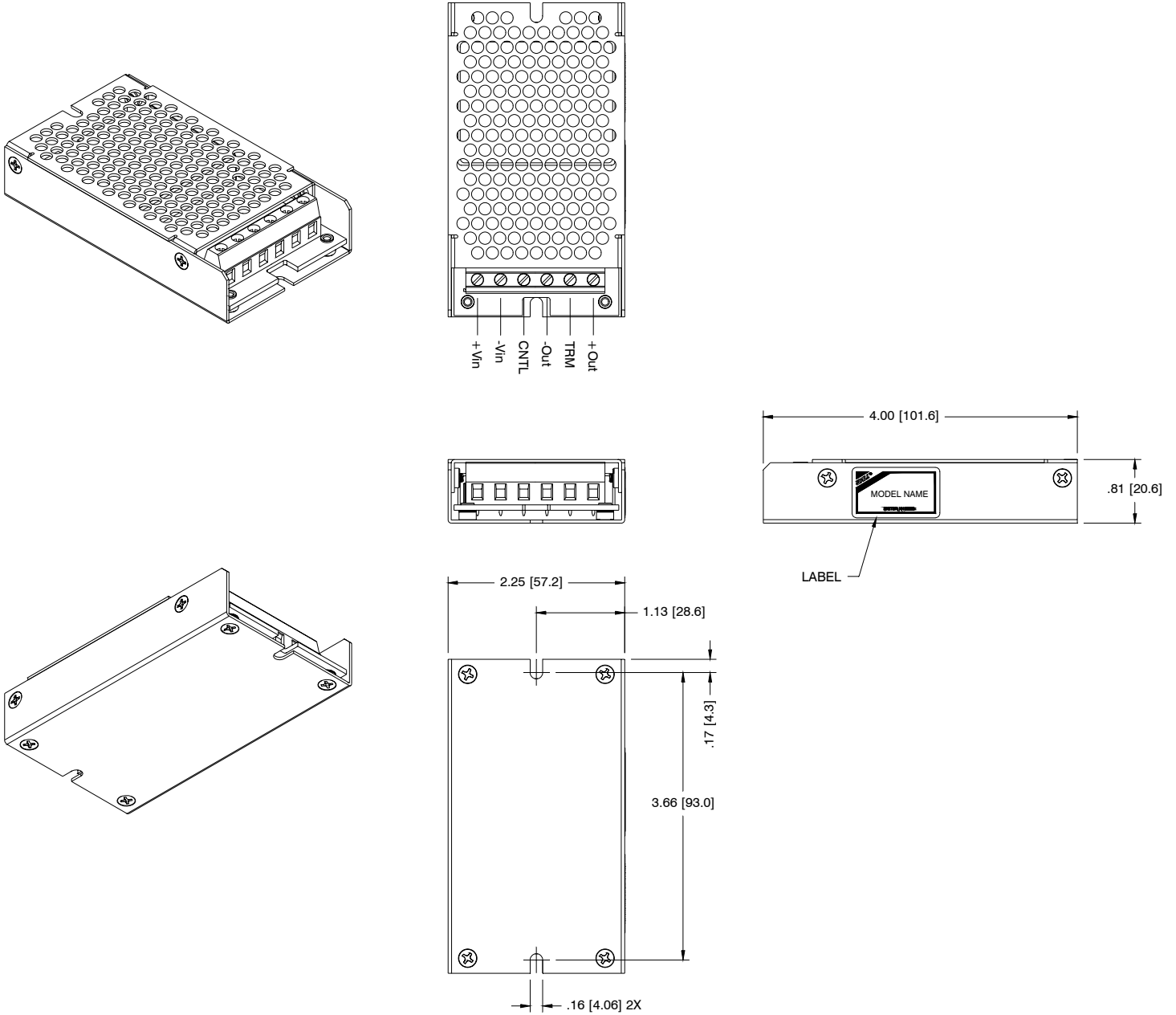

Equip Heatsink (7G-0020C-F) for lower temperature and higher reliability of the module. Consider space and airflow in order to choose which heatsink is needed.

Figure 2

Unit: inches (mm)

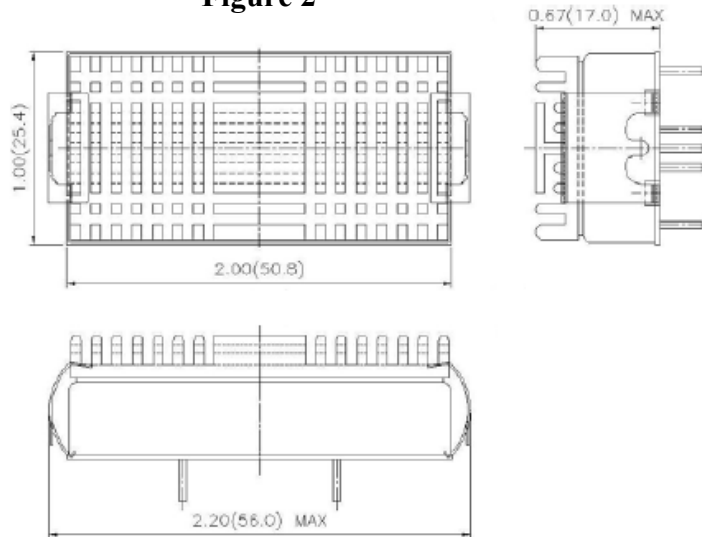

DESIGN CONSIDERATIONS:**Output Over Current Protection**

When excessive output current occurs in the system, circuit protection is required on all power supplies. Normally, overload current is maintained at approximately 140% of rated current for the CMMDW single output series.

Hiccup mode is a method of operation in a power supply whose purpose is to protect the power supply from being damaged during an over-current fault condition. It also enables the power supply to restart when the fault is removed. There are other ways of protecting the power supply when it is over loaded such as maximum current limiting or current fold-back methods.

One of the problems resulting from over current is that excessive heat may be generated in power devices; especially MOSFET and Schottky diodes and the temperature of those devices may exceed their specified limits. A protection mechanism has to be used to prevent those power devices from being damaged.

The operation of hiccup is as follows. When the current sense circuit sees an over current event, the controller shuts off the power supply for a given time and then tries to start up the power supply again. If the over load condition has been removed, the power supply will start up and operate normally; otherwise, the controller will see another over current event and shut off the power supply again repeating the previous cycle. Hiccup operation has none of the drawbacks of the other two protection methods, although its circuit is more complicated because it requires a timing circuit. The excess heat due to over load lasts for only a short duration in the hiccup cycle, hence the junction temperature of the power devices is much lower.

The hiccup operation can be done in various ways. For example, one can start the hiccup operation any time an over current event is detected, or prohibit hiccup during a designated start-up which is usually larger than during normal operation and it is easier for an over current event to be detected, or prohibit hiccup during a designated start-up interval (usually a few milliseconds). The reason for the latter operation is that during start-up the power supply needs to provide extra current to charge up the output capacitor thus the current demand is usually larger than during normal operation making it easier for an over current event to occur. If the power supply starts to hiccup once there is over current it might never start up successfully. Hiccup mode protection will give the best protection for a power supply against over current situations since it will limit the average current to the load at a low level reducing power dissipation and case temperature in the power devices.

Output Over Voltage Protection

The output over voltage protection consists of an output Zener diode that monitors the voltage on the output terminals. If the voltage on the output terminals exceeds the over voltage protection threshold, then the Zener diode will clamp the output voltage.

Short Circuit Protection

Continuous, hiccup, and auto-recovery mode. The average current during this condition will be very low and the device is still safe in this condition.

Input Source Impedance

The power module should be connected to a low impedance input source. Highly inductive source impedance can affect the stability of the power module. Input external L-C filter is recommended to minimize input reflected ripple current. The inductor is simulated source impedance of 12 μ H and capacitor is Nippon chemi-con KZE series 220 μ F/100V. The capacitor must be connected as close as possible to the input terminals of the power module for lower impedance.

Thermal Consideration

The power module operates in a variety of thermal environments. However, sufficient cooling should be provided to help ensure reliable operation of the unit. Heat is removed by conduction, convention, and radiation to the surrounding environment. Proper cooling can be verified by measuring the point as the figure below. The temperature at this location should not exceed 105°C. When operating, adequate cooling must be provided to maintain the test point temperature at or below 105°C. Although the maximum point temperature of the power modules is 105°C, you can limit this temperature to a lower value for extremely high reliability.

Figure 3

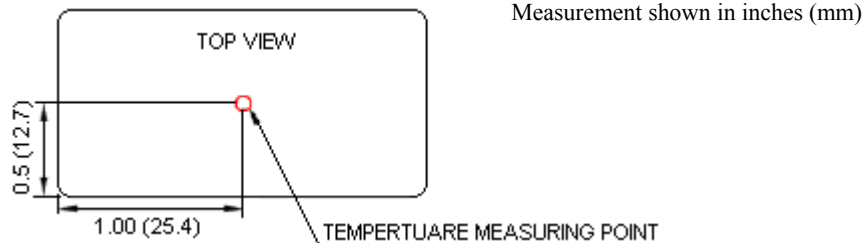

Output Voltage Adjustment

Output voltage set point adjustment allows the user to increase or decrease the output voltage set point of a module. This is accomplished by connecting an external resistor between the TRIM pin and either the +Vout or -Vout pins. With an external resistor between the TRIM and -Vout pin, the output voltage set point increases. With an external resistor between the TRIM and +Vout pin, the output voltage set point decreases.

Figure 4

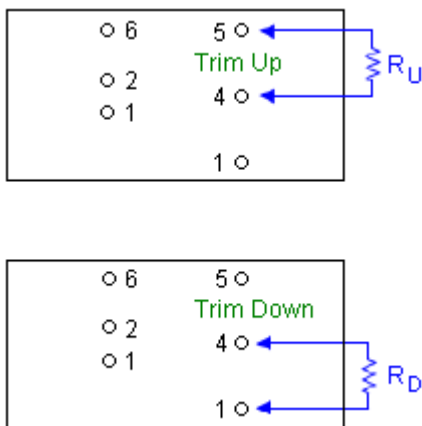

Table 1

CMMDW48S3.3-5500				
Trim	Trim _{up}	R _{up}	Trim _{down}	R _{down}
1%	3.333V	57.930 kΩ	3.267V	69.470 kΩ
2%	3.366V	26.165 kΩ	3.234V	31.235 kΩ
3%	3.399V	15.577 kΩ	3.201V	18.490 kΩ
4%	3.432V	10.283 kΩ	3.168V	12.117 kΩ
5%	3.465V	7.106 kΩ	3.135V	8.294 kΩ
6%	3.498V	4.988 kΩ	3.102V	5.745 kΩ
7%	3.531V	3.476 kΩ	3.069V	3.924 kΩ
8%	3.564V	2.341 kΩ	3.036V	2.559 kΩ
9%	3.597V	1.459 kΩ	3.003V	1.497 kΩ
10%	3.630V	0.853 kΩ	2.970V	0.647 kΩ

Remote ON/OFF Control

The remote ON/OFF pin allows the user to turn the DC/DC power module on and off from a remote switch device. The ON/OFF input can be switched by a number of switching devices. Figure 5 gives several examples of acceptable configurations. The remote ON/OFF pin is an open collector/drain logic input signal that is referenced to $-V_{in}$. A logic High on the remote ON/OFF pin turns the module ON and a logic Low on the remote ON/OFF pin turns the module OFF. If the remote ON/OFF feature is not being used please make an open circuit between the ON/OFF pin and the $-$ input pin to turn the module on.

Remote ON/OFF Implementation

Figure 5

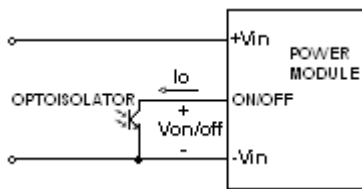

Isolated-Closure Remote ON/OFF

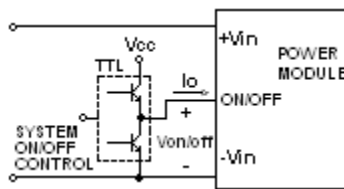

Level Control Using TTL Output

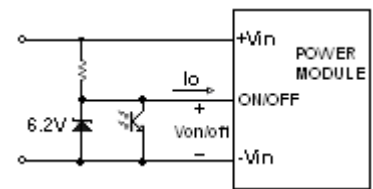

Level Control Using Line Voltage

CMMDW48S3.3-5500 Graphs. *All test conditions are at 25°C*

Graph 1: Efficiency vs. Output Current

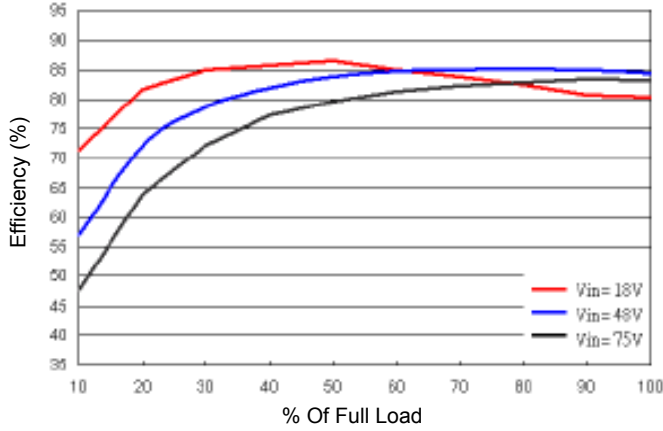

Graph 2: Efficiency vs. Input Voltage (Full Load)

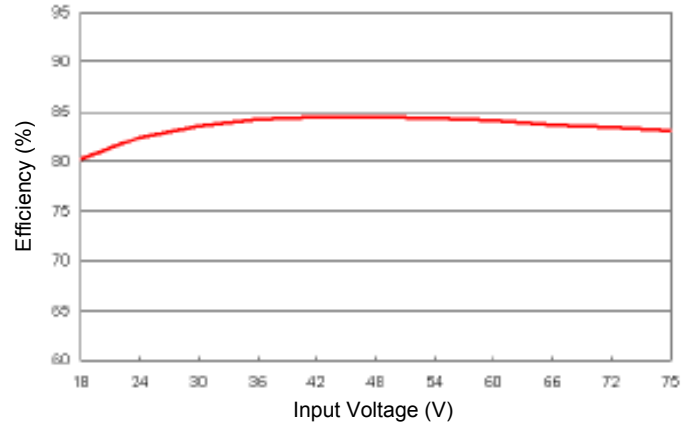

Graph 3: Output Power vs. Ambient Temperature & Airflow (Nominal Vin)

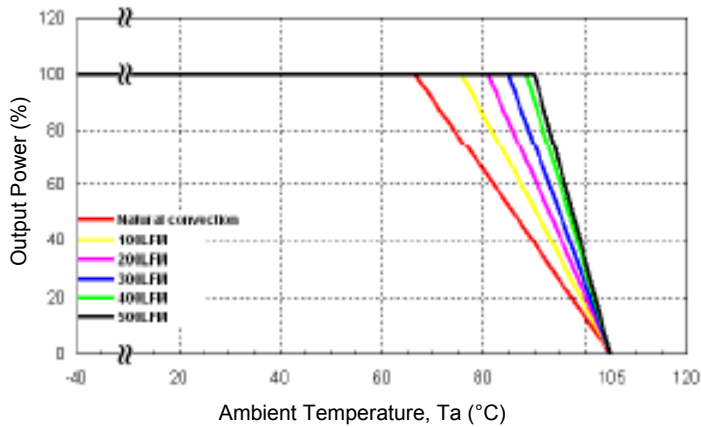

Graph 4: Output Power vs. Ambient Temperature with Heatsink & Airflow (Nominal Vin)

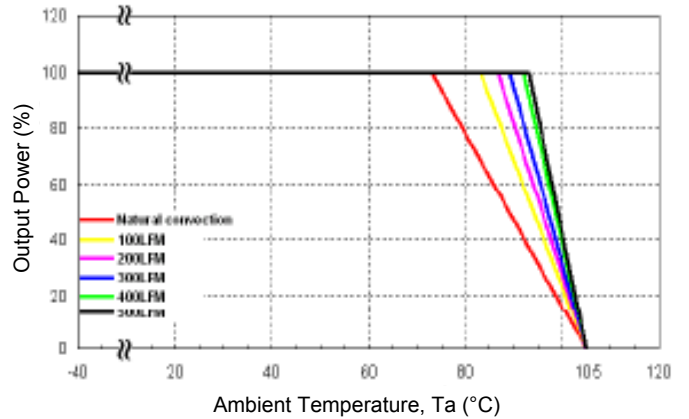

Graph 5: Power Dissipation Vs. Output Current

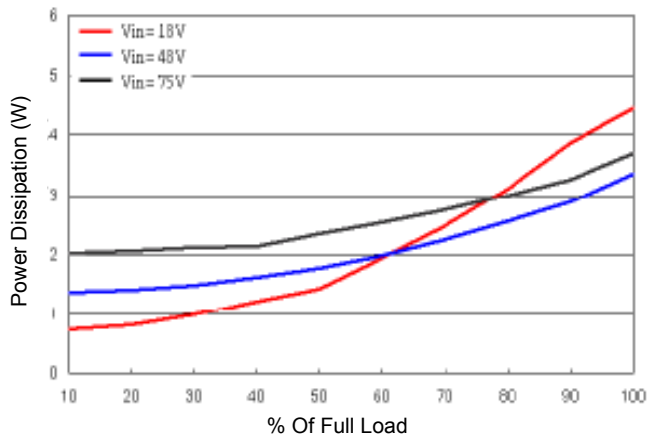

TEST SETUP:

The CMMDW48S3.3-5500 specifications are tested with the following configurations:

Input Reflected-Ripple Current Measurement Test Setup

Figure 6

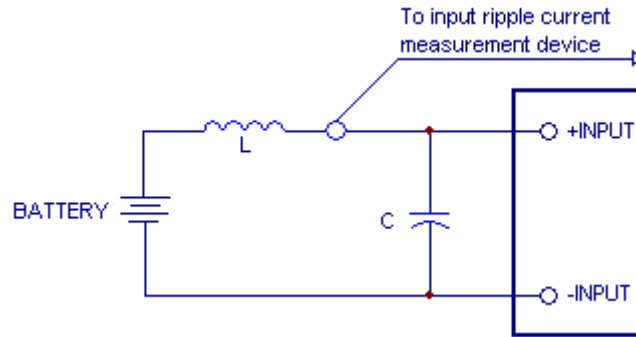

Component	Value	Voltage	Reference
L	12μH	----	----
C	100μF	100V	Aluminum Electrolytic Capacitor

Peak-to-Peak Output Ripple & Noise Measurement Setup

Figure 7

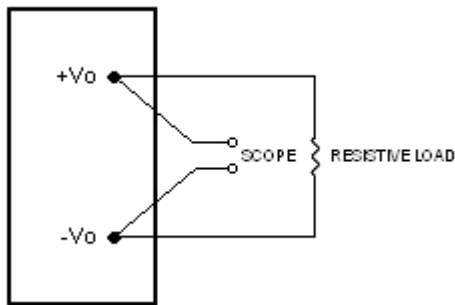
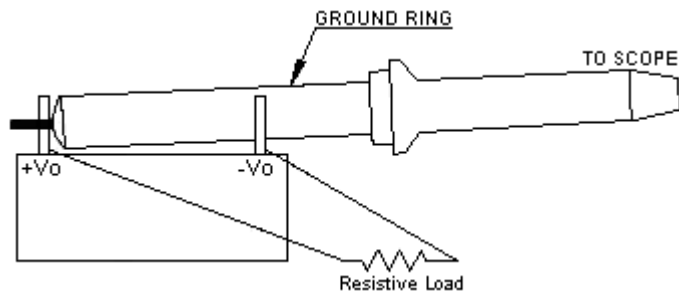
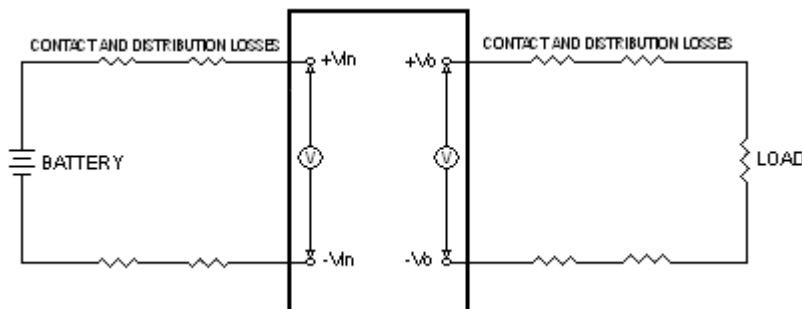

Figure 8



Output Voltage and Efficiency Measurement Setup

Figure 9



$$Efficiency = \left(\frac{V_{out} \times I_{out}}{V_{in} \times I_{in}} \right) \times 100\%$$

NOTE: All measurements are taken at the module terminals

Soldering and Reflow Considerations:

Lead Free Wave Solder Profile for CMMDW Single Output Models

Figure 10

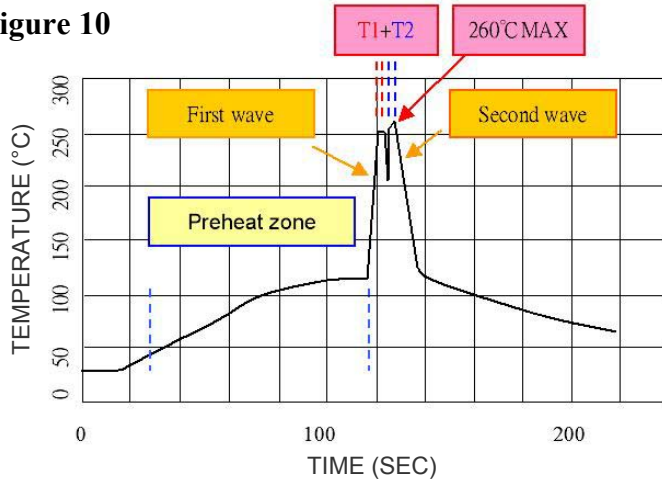

Zone	Reference Parameter
Preheat Zone	Rise temp. speed: 3°C/sec max. Preheat temp: 100~130°C
Actual Heating	Peak temp: 250~260°C Peak time (T1+T2 time): 4~6 sec

Reference Solder: Sn-Ag-Cu; Sn-Cu

Hand Welding: Soldering Iron: Power 90W
Welding Time: 2~4 sec
Temp: 380~400°C

Safety and Installation Instructions:

Fusing Consideration

Caution: This power module is not internally fused. An input line fuse must always be used. This encapsulated power module can be used in a wide variety of applications, ranging from simple stand-alone operation to an integrated part of sophisticated power architecture. For maximum flexibility internal fusing is not included; however, to achieve maximum safety and system protection always use an input line fuse. The safety agencies require a normal-blow fuse with maximum rating of 6A. Based on the information provided in this data sheet on inrush energy and maximum DC input current; the same type of fuse with lower rating can be used. Refer to the fuse manufacturer’s data for further information.

MTBF and Reliability

The MTBF of the CMMDW single output series of DC/DC converters has been calculated using Bellcore TR-NWT-000332 Case I: 50% stress, Operating Temperature at 40°C (Ground fixed and controlled environment). The resulting figure for MTBF is 1,621,000 hours.

MIL-HDBK 217F NOTICE2 FULL LOAD, Operating Temperature at 25°C. The resulting figure for MTBF is 659,000 hours.

Ordering Information:

Part Number Example:

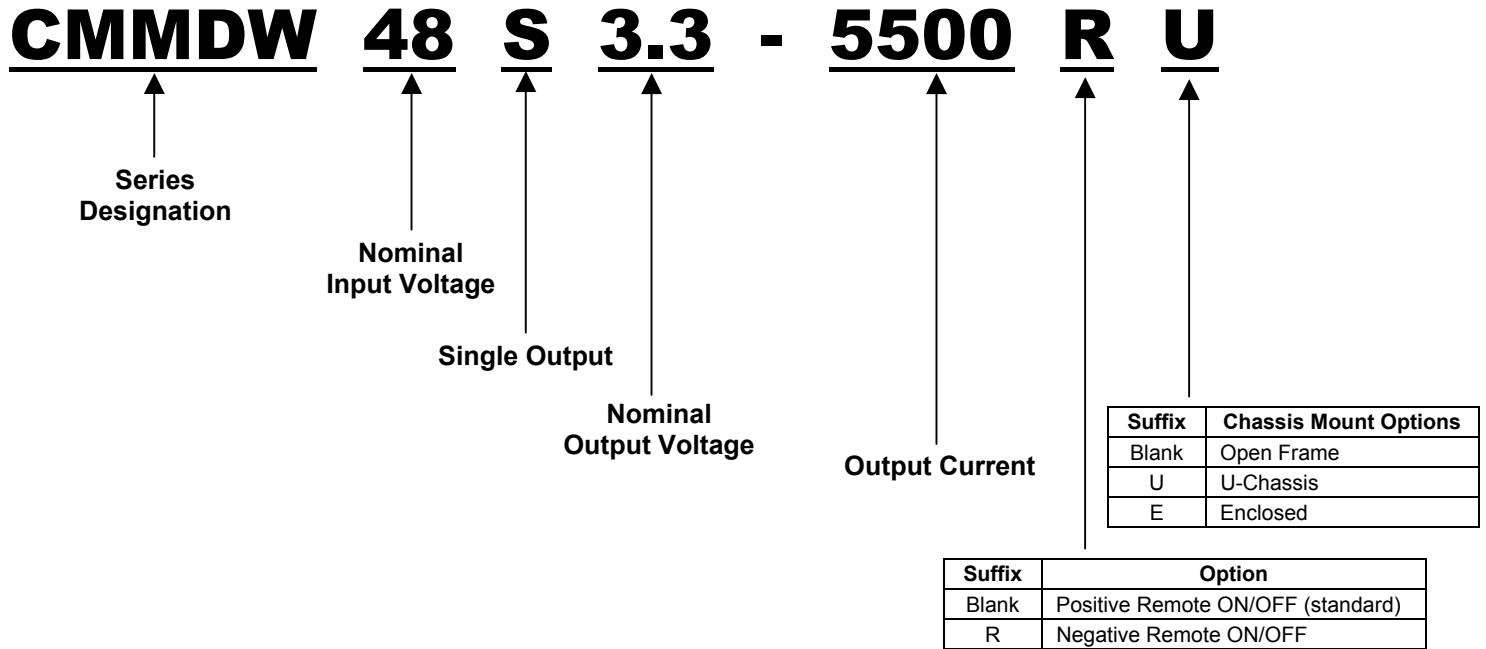
**Company Information:**

Wall Industries, Inc. has created custom and modified units for over 40 years. Our in-house research and development engineers will provide a solution that exceeds your performance requirements on time and on budget. Our ISO9001-2000 certification is just one example of our commitment to producing a high quality, well-documented product for our customers.

Our past projects demonstrate our commitment to you, our customer. Wall Industries, Inc. has a reputation for working closely with its customers to ensure each solution meets or exceeds form, fit and function requirements. We will continue to provide ongoing support for your project above and beyond the design and production phases. Give us a call today to discuss your future projects.

Contact **Wall Industries** for further information:

Phone: ☎(603)778-2300
Toll Free: ☎(888)587-9255
Fax: ☎(603)778-9797
E-mail: sales@wallindustries.com
Web: www.wallindustries.com
Address: 5 Watson Brook Rd.
 Exeter, NH 03833