

High Speed GaAlAs Infrared Emitter

OPE5585

The **OPE5585** is GaAlAs infrared emitting diode that is designed for high power, low forward voltage and high speed rise / fall time.

This device is optimized for speed and efficiency at emission wavelength 850nm and has a high radiant efficiency over a wide range of forward current. This device is packaged T1-3/4 plastic package and has narrow beam angle with lensed package and cup frame. Especially this device is suited as the emitter of data transmission without cable.

FEATURES

- High speed : 25ns rise time
- 850nm wavelength
- Narrow beam angle
- Low forward voltage
- High power and high reliability
- Available for pulse operating

APPLICATIONS

- Emitter of IrDA
- IR Audio and Telephone
- High speed IR communication
- IR LANs
- Available for wireless digital data transmission

STORAGE

- Condition : 5°C~35°C,R.H.60%
- Terms : within 3 months from production date
- Remark : Once the package is opened, the products should be used within a day. Otherwise, it should be keeping in a damp proof box with desiccants.

* Please take proper steps in order to secure reliability and safety in required conditions and environments for this device.

DIMENSIONS(Unit : mm)

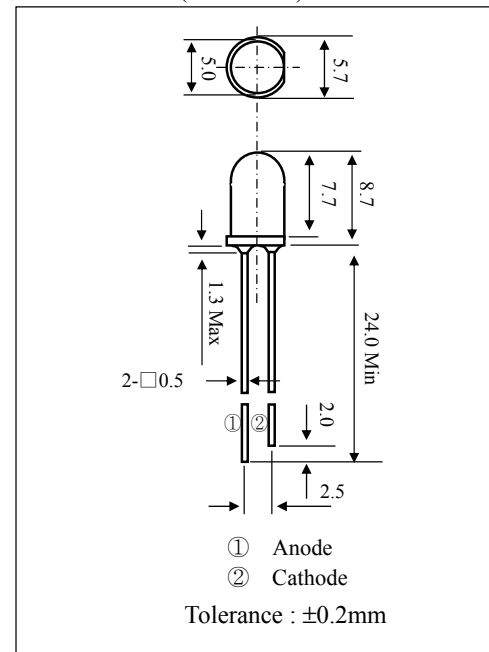

MAXIMUM RATINGS

(Ta=25°C)

Item	Symbol	Rating	Unit
Power Dissipation	P_D	150	mW
Forward current	I_F	100	mA
Pulse forward current *1	I_{FP}	1.0	A
Reverse voltage	V_R	4.0	V
Operating temp.	Topr.	-25~+85	°C
Soldering temp. *2	Tsol.	260.	°C

*1.Duty ratio = 1/100, pulse width=0.1ms.

*2.Lead Soldering Temperature (2mm from case for 5sec.).

ELECTRO-OPTICAL CHARACTERISTICS

(Ta=25°C)

Item	Symbol	Conditions	Min.	Typ.	Max.	Unit
Forward voltage	V_F	$I_F=50mA$		1.5	2.0	V
Reverse current	I_R	$V_R=4V$			10	μA
Capacitance	C_t	$f=1MHz$		20		pF
Radiant intensity	I_e	$I_F=50mA$	40	100		mW/sr
Peak emission wavelength	λ_p	$I_F=50mA$		850		nm
Spectral bandwidth 50%	$\Delta \lambda$	$I_F=50mA$		45		nm
Half angle	$\Delta \theta$	$I_F=50mA$		± 10		deg.
Optical rise & fall time(10%~90%)	tr/tf	$I_F=50mA$		25/13		ns
Cut off frequency *3	fc	$I_F=50mA$ DC +10mA p-p		14		MHz

*3. $10 \log P_o(fc \text{ MHz}) / P_o(0.1 \text{ MHz}) = -3$

- **FORWARD CURRENT Vs. AMBIENT TEMP.**

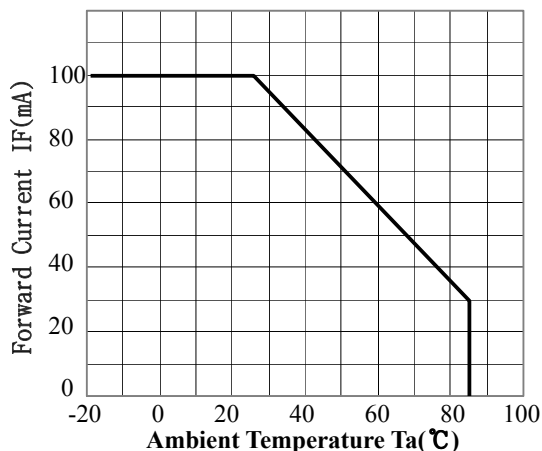

- **RADIANT INTENSITY Vs. FORWARD CURRENT.**

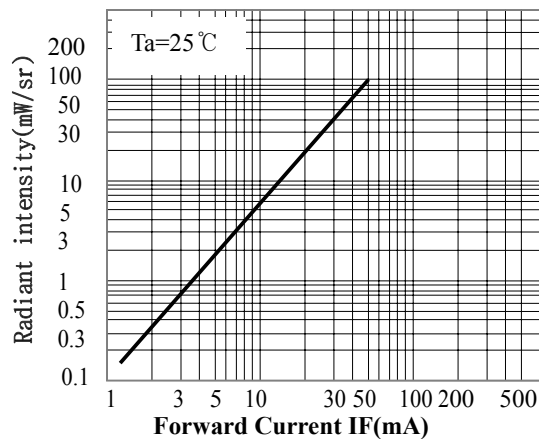

- **RELATIVE RADIANT INTENSITY Vs. AMBIENT TEMP.**

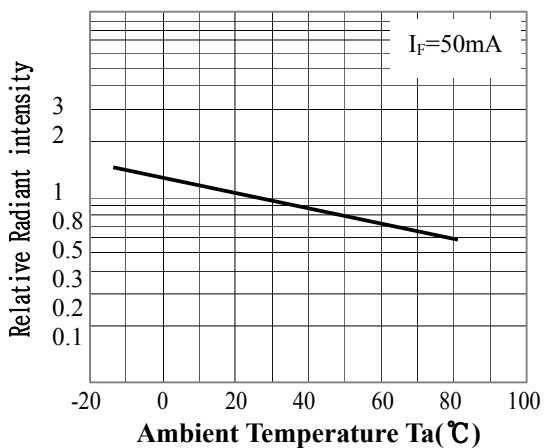

- **RELATIVE RADIANT INTENSITY Vs. EMISSION WAVELENGTH.**

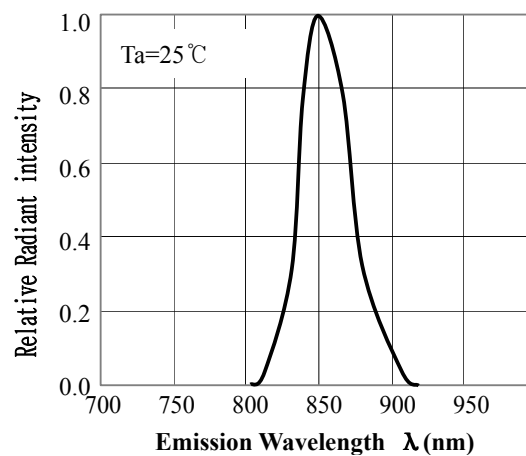

- **FORWARD CURRENT Vs. FORWARD VOLTAGE**

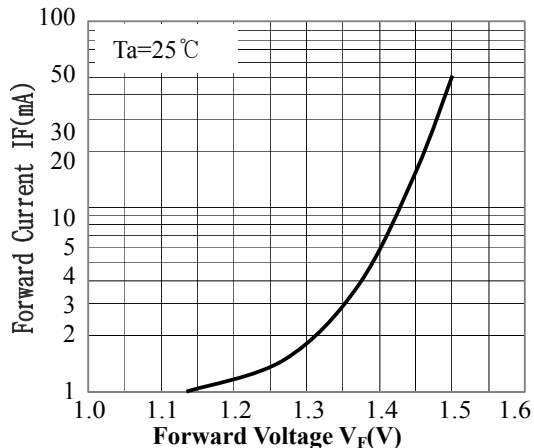

- **ANGULAR DISPLACEMENT Vs. RELATIVE RADIANT INTENSITY**

