

# AlGaInP Ultra Bright Red LED Lamp

## OPE5164UR

The **OPE5164UR** is AlGaInP ultra bright light emitting diode that is designed for ultra brightness and excellent reliability. This device is optimized for efficiency at peak wavelength 639nm.

This device is packaged T13/4 plastic package and has medium beam angle with lensed package and cup frame.

### FEATURES

- Ultra brightness
- Peak wavelength : 639nm
- Medium beam angle
- Excellent reliability
- Available for pulse operating

### APPLICATIONS

- PIXEL cluster
- LED Dot Matrix
- Traffic signal
- Display signboard

### STORAGE

- Condition : 5°C~35°C,R.H.60%
- Terms : within 3 months from production date
- Remark : Once the package is opened, the products should be used within a day. Otherwise, it should be keeping in a damp proof box with desiccants.

\* Please take proper steps in order to secure reliability and safety in required conditions and environments for this device.

DIMENSIONS (Unit : mm)

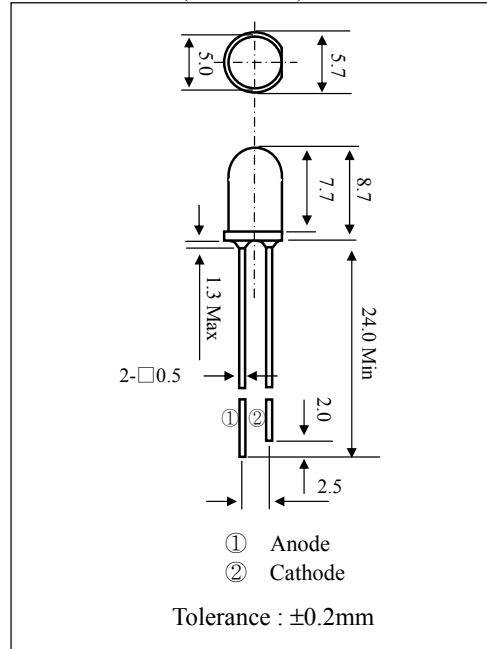

### MAXIMUM RATINGS

(Ta=25°C)

Item	Symbol	Rating	Unit
Power dissipation	$P_D$	40	mW
Forward current	$I_F$	30	mA
Pulse forward current <sup>*1</sup>	$I_{FP}$	50	mA
Reverse voltage	$V_R$	4	V
Operating temp.	Topr.	-25~+85	°C
Soldering temp. <sup>*2</sup>	Tsol.	260.	°C

<sup>\*1</sup>.Duty ratio = 1/100, pulse width=0.1ms.

<sup>\*2</sup>.Lead soldering temperature (2mm from case for 5sec.).

### ELECTRO-OPTICAL CHARACTERISTICS

(Ta=25°C)

Item	Symbol	Conditions	Min.	Typ.	Max.	Unit
Luminous intensity	$I_V$	$I_F=20mA$				mcd
Peak emission wavelength	$\lambda_p$	$I_F=20mA$		639		nm
Spectral bandwidth	$\Delta\lambda$	$I_F=20mA$		20		nm
Forward voltage	$V_F$	$I_F=20mA$		2.0	2.3	V
Reverse current	$I_R$	$V_R=4V$			100	$\mu A$
Half angle	$\Delta\theta$	$I_F=20mA$		±10		deg.

● FORWARD CURRENT Vs. AMBIENT TEMP

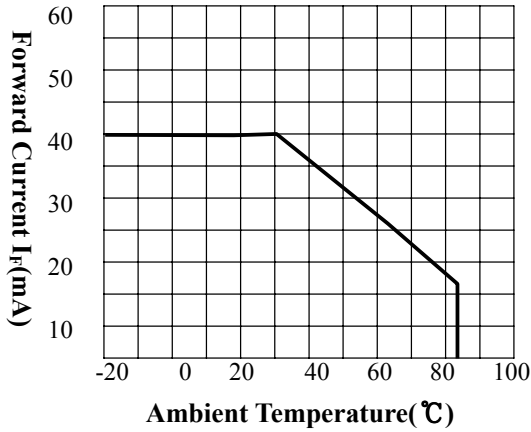

● LUMINOUS INTENSITY Vs. FORWARD CURRENT

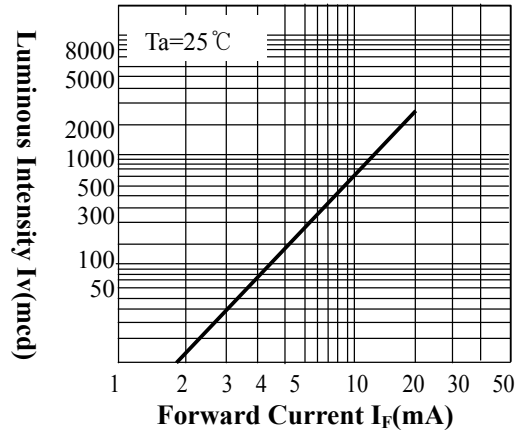

● RELATIVE LUMINOUS INTENSITY Vs. AMBIENT TEMP.

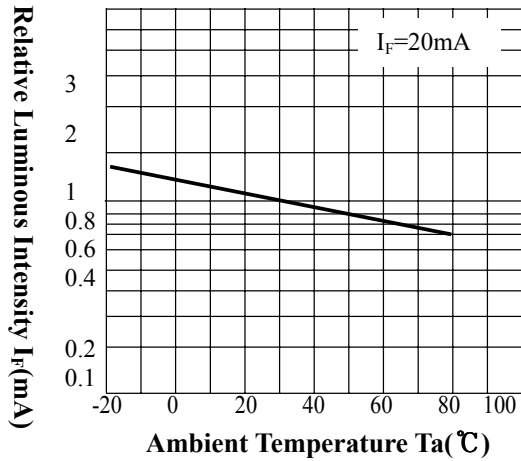

● RELATIVE LUMINOUS INTENSITY Vs. EMISSION WAVELENGTH.

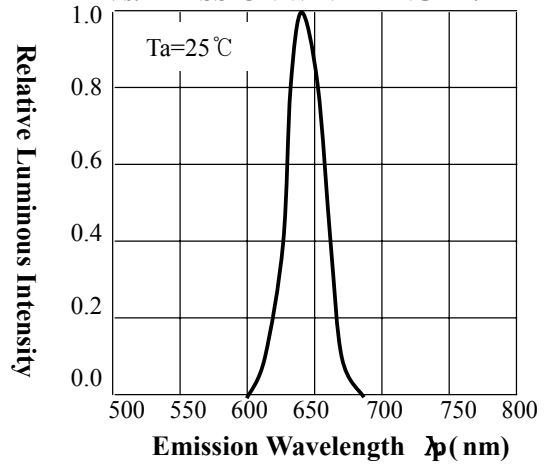

● FORWARD CURRENT Vs. FORWARD VOLTAGE

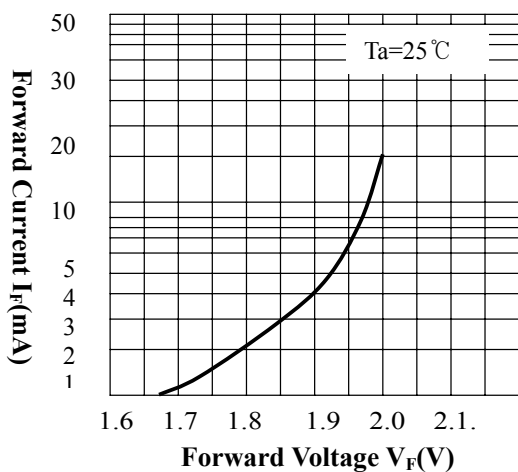

● RELATIVE LUMINOUS INTENSITY Vs. ANGULAR DIAPLACEMENT

