



PICO-AMP Features

- Ultra-small remote sensors to fit the tightest locations
- Three fixed frequency selections or Auto Frequency mode to prevent crosstalk in multiple-sensor applications
- Amplifier clips to 35 mm DIN rail for easy mounting
- Diffuse- or opposed-mode sensors are available
- Opposed-mode sensors are sold in pairs
- Opposed-mode range is 300 mm; diffuse-mode range is 50 mm
- Amplifiers and sensors are sold separately
- Yellow indicator on emitter signals when light is sensed; Yellow indicator on amplifier signals light sensed and flashes to indicate marginal excess gain (between 1.0 and 1.5x)
- An excellent option for wafer handling applications, small parts sensing and pharmaceuticals applications

PICO-AMP MD14 Amplifier Models

Models	Sensor Compatibility	Cable	Supply Voltage	Output Type
MD14BB6	SP3ER1 SP3ER2 SP8ER1	2 m (6.5')	10-30V dc	Bipolar, NPN/PNP
MD14BB6Q	SP8ER2 SP3D1	4-pin Pico-style QD		

*NOTE: 9 m (30') cables are available by adding suffix "W/30" to the model number of the cabled sensor (e.g., **MD14BB6 W/30**)



WARNING . . . Not a Safety Device

These remote sensors and component amplifiers do NOT include the self-checking redundant circuitry necessary to allow their use in personnel safety applications. A sensor or amplifier failure or malfunction can result in either an energized or a de-energized amplifier output condition.

Never use these products as sensing devices for personnel protection. Their use as a safety device may create an unsafe condition which could lead to serious injury or death.

Only MICRO-SCREEN™, MINI-SCREEN®, MULTI-SCREEN®, MACHINE-GUARD™ and PERIMETER-GUARD™ Systems, and other systems so designated, are designed to meet OSHA and ANSI machine safety standards for point-of-operation guarding devices. No other Banner sensors or controls are designed to meet these standards, and they must NOT be used as sensing devices for personnel protection.

PICO-AMP Miniature Remote Sensing System

PICO-AMP MD14 Amplifier Specifications

Sensor compatibility	PICO-AMP amplifier models MD14BB6 and MD14BB6Q are compatible with the following remote sensors: SP3ER1, SP3ER2, SP8ER1, SP8ER2, SP3D1										
Supply voltage and current	10 to 30V dc (10% maximum ripple) at less than 55 mA (exclusive of load)										
Supply Protection Circuitry	Protected against reverse polarity and transient voltages.										
Output Configuration	Bipolar, one current sourcing (PNP) and one current sinking (NPN) open-collector transistor										
Output Rating	100mA maximum, each output Off-state Leakage Current: less than 5 μ A Output Saturation Voltage: PNP output less than 1V @10mA; less than 1.5V @ 100mA NPN output less than 0.2V @ 10mA; less than 0.75V @ 100mA										
Output Protection Circuitry	Protected against false pulse on power-up and continuous overload or short-circuit of outputs										
Output Response Time	<table border="0"> <thead> <tr> <th>Frequency Selection</th> <th>Response Time</th> </tr> </thead> <tbody> <tr> <td>Auto</td> <td>500 microseconds ON/ 350 microseconds OFF</td> </tr> <tr> <td>Freq 1</td> <td>350 microseconds ON/ 250 microseconds OFF</td> </tr> <tr> <td>Freq 2</td> <td>450 microseconds ON/ 300 microseconds OFF</td> </tr> <tr> <td>Freq 3</td> <td>500 microseconds ON/ 350 microseconds OFF</td> </tr> </tbody> </table> <p>NOTE 1: Auto mode defaults to Freq 1 at power-up NOTE 2: Response time will increase with adjacent sensor interference.</p>	Frequency Selection	Response Time	Auto	500 microseconds ON/ 350 microseconds OFF	Freq 1	350 microseconds ON/ 250 microseconds OFF	Freq 2	450 microseconds ON/ 300 microseconds OFF	Freq 3	500 microseconds ON/ 350 microseconds OFF
Frequency Selection	Response Time										
Auto	500 microseconds ON/ 350 microseconds OFF										
Freq 1	350 microseconds ON/ 250 microseconds OFF										
Freq 2	450 microseconds ON/ 300 microseconds OFF										
Freq 3	500 microseconds ON/ 350 microseconds OFF										
Adjustments/programming	Light/Dark Operate Select switch OFF-delay Select switch: 0 or 50 ms 4-position Frequency Select switch: Auto, Freq 1, Freq 2, Freq 3 12-turn slotted brass screw Gain (Sensitivity) adjustment potentiometer (clutched at both ends of travel)										
Indicators	Green: ON Steady = Power to amplifier is ON Flashing = Output is overloaded Yellow: ON Steady = Light is sensed Flashing = Marginal excess gain (1 to 1.5x) in light condition										
Construction	Housing: Yellow polycarbonate/ABS alloy, rated UL94 V-0 Cover: Gray-tinted polycarbonate DIN spring clip: Yellow Delrin® (acetal)										
Environmental Rating	IP50, NEMA 1										
Connections	Sensor(s): four M2.5 zinc-plated steel SEMS screws Power and Outputs: PVC-jacketed 4-conductor 2m (6.5') or 9 m (30') attached cable, or 4-pin Pico-style quick-disconnect fitting QD cables are ordered separately (see Accessories)										
Operating Conditions	Temperature: 0° to +55° C (+32° to 131°F) Maximum relative humidity: 90% at 50° C (non-condensing)										
Application Notes	Always remove power to amplifier before connecting or disconnecting sensors. See page 3 for a discussion of the Frequency selection; Manual frequency selection increases sensing hysteresis.										
Certifications											

Delrin® is a registered trademark of Dupont Co.

PICO-AMP Miniature Remote Sensing System

PICO-AMP MD14 Amplifier Description

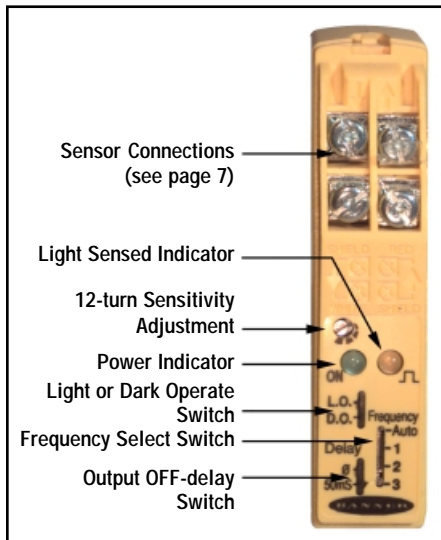

Figure 1. MD14 amplifier features (shown with cover removed)

Amplifier Features

Operating indicators and selectors are located under the transparent, hinged cover for convenient adjustment.

Light or Dark Operate Selection

Choose light or dark operate (the output energizes when the light condition is sensed if set to light operate; it energizes when the dark condition is sensed if set to dark operate).

Sensitivity Adjustment

Amplifier gain is increased with clockwise rotation of the 12-turn Sensitivity Adjustment, using the small, flat-blade screwdriver included with the MD14 (or equivalent). The Sensitivity Adjustment is clutched at both ends of travel to prevent damage.

LED Indicators

The green LED lights whenever power is applied to the MD14. It will flash if either output becomes overloaded.

The yellow LED lights when the MD14 senses its own modulated light. It will flash if the received light signal strength becomes marginal (excess gain between 1.0 and 1.5x). It lights steadily for received light signal strengths greater than 1.5x excess gain.

Output OFF-delay

A two-position switch selects either no output delay or a 50-millisecond pulse stretcher (OFF-delay). The OFF-delay is beneficial in applications where a very short sensing event might be missed due to slow response of the load or input connected to one or both sensor outputs.

Frequency Selection

A four-position switch selects one of three modulation frequencies, or Auto Frequency mode. The multiple frequencies allow up to three PICO-AMP sensors to be placed together, in close proximity, without mutual interference (without optical "crosstalk").

Auto Frequency mode is recommended for all applications (even when crosstalk potential is not an issue), except in certain mutual interference situations where the strength of either the intended or interfering light signal is near the switching threshold. In these cases, the best sensing performance is achieved by manually setting interfering sensors to alternate modulation frequencies.

NOTE:

- 1) The strength of an interfering light signal may be substantial, but should not exceed the strength of the intended light signal.
- 2) The MD14 is not designed to ignore the light from other modulated sensor families.
- 3) Manual frequency selections increase sensing hysteresis.
- 4) Auto Frequency mode defaults to Freq 1 at power-up.

PICO-AMP Miniature Remote Sensing System

Amplifier Dimensions

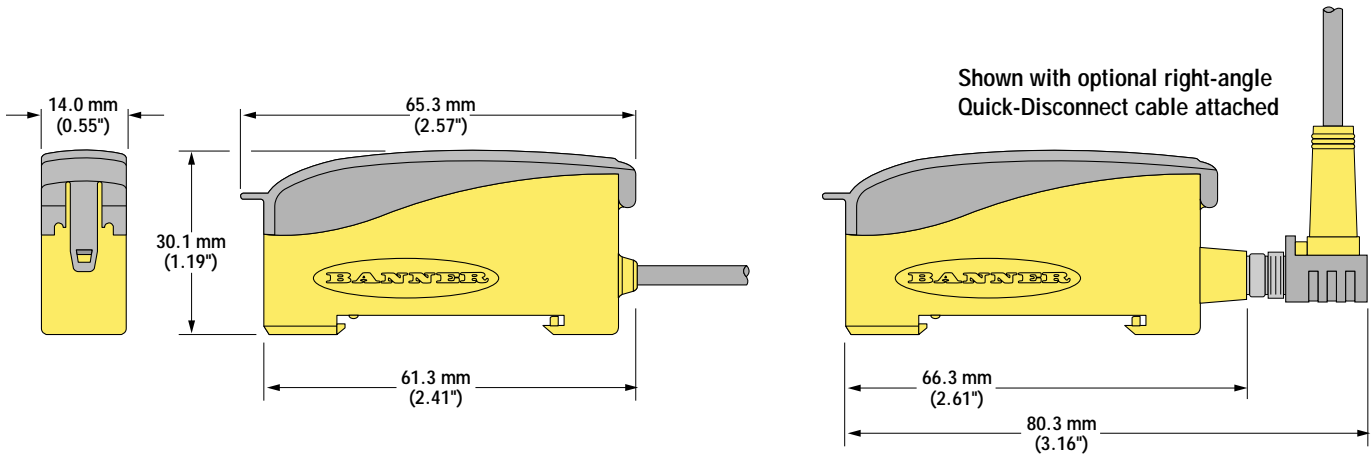

Mounting the Amplifier to DIN Rail

The MD14 amplifier is made to fit securely onto 35 mm DIN rail. To mount the amplifier, simply slide the bottom of the housing onto one lip of the DIN rail; then push forward and down to snap the housing onto the other lip. (See Figure 2.)

To remove the MD14 from the DIN rail, push forward to retract the spring clip and lift the front lip away from the rail.

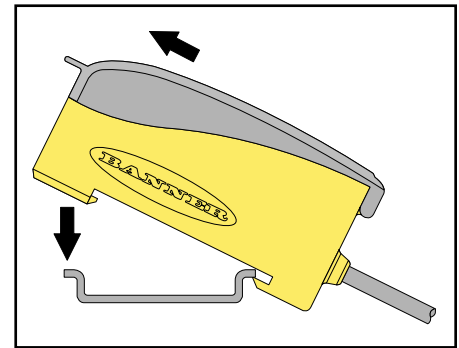
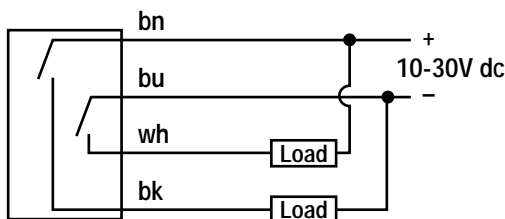

Figure 2. Mounting the PICO-AMP MD14 amplifier

PICO-AMP MD14 Amplifier Hookups

With Attached Cable





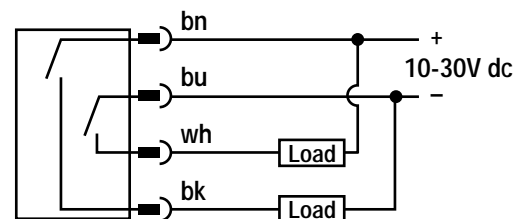

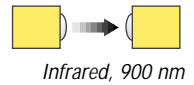

With Quick-disconnect

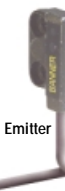
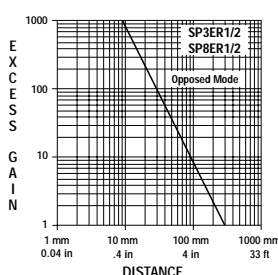
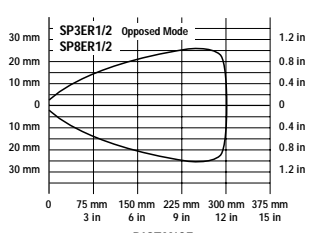

PICO-AMP Miniature Remote Sensing System



SP3/SP8 Opposed-Mode Remote Sensors

Models*	Orientation/ Mounting	Cable	Range	Housing Material	Excess Gain	Beam Pattern
SP3ER1	Receiver  Emitter 	Parallel Coaxial 2 m (6.5')	300 mm	Black ABS		
SP3ER2	Emitter  Receiver 					
SP8ER1	Receiver  Emitter 					
SP8ER2	Emitter  Receiver 					

*NOTE: Opposed-mode sensors are shipped in connected pairs (one emitter and one receiver). The emitter includes a yellow LED which is ON whenever the receiver senses light from its emitter. The housing of the receiver will be the "mirror image" of its corresponding emitter.

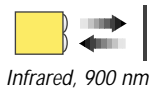

SP3D1 Diffuse-Mode Remote Sensor

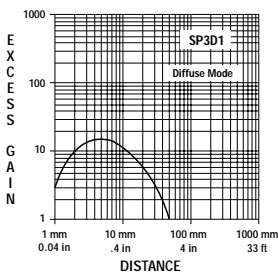
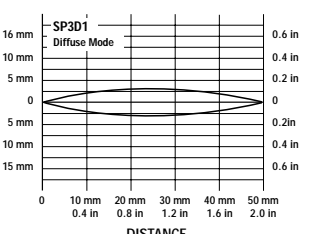
Model	Orientation/ Mounting	Cable	Range	Housing Material	Excess Gain	Beam Pattern
SP3D1		Parallel Coaxial 2 m (6.5')	50 mm	Black ABS		

PICO-AMP Miniature Remote Sensing System

SP3/SP8 Remote Sensor Specifications

Sensor Models	Opposed-mode emitter/receiver pairs: SP3ER1, SP3ER2, SP8ER1, SP8ER2 Diffuse-mode: SP3D1
Amplifier Compatibility	MD14
Indicators	Yellow: ON Steady = Light is sensed NOTE: This indicator is located on the emitter of opposed-mode sensors.
Construction	Black ABS housing
Mounting Hardware	Two each M2 x 0.4 mm x 8 mm Phillips pan-head zinc-plated steel machine screws, flat washers, lockwashers, and hex nuts for each sensor
Environmental Ratings	IP50, NEMA 1
Connections	2-part parallel/joined coaxial cable: Each part is PVC-jacketed, .065" O.D., 2-conductor 2 m (6.5') cable with 28 AWG insulated center conductor and spiral wrap shield
Operating Conditions	Temperature: -20° to 70° C (-5° to +158°F) Maximum relative humidity: 90% at 50° C (non-condensing)
Application Notes	Avoid mounting sensor wires near high-current circuits or inductive sources. Always remove power to amplifier before connecting or disconnecting sensors. Sensor cable length should not exceed 9 m (30').

SP3/SP8 Dimensions

SP3ER Models

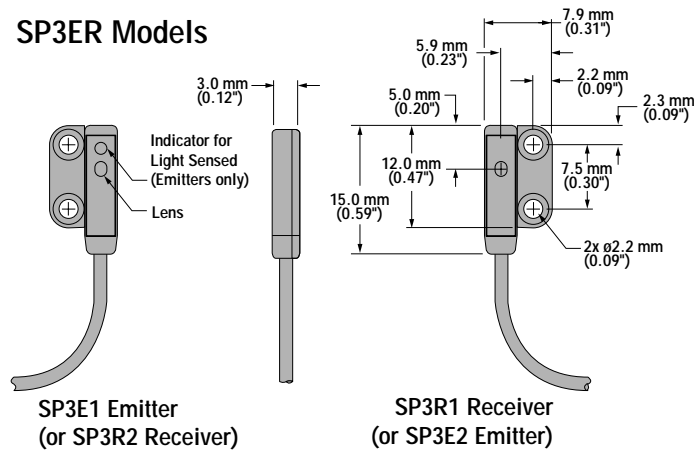

SP8ER Models

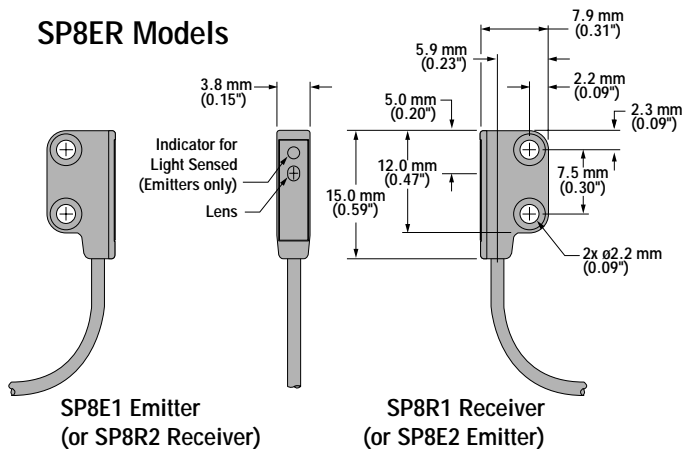

SP3D1

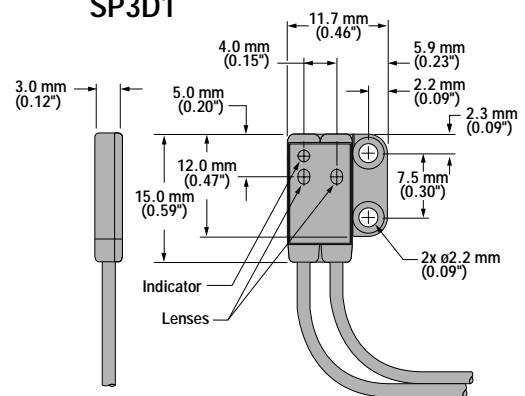

PICO-AMP Miniature Remote Sensing System

Mounting the Sensors

Opposed-mode sensors are shipped in connected pairs (one emitter and one receiver), with a 6' cable attached; the cable comes split to 6"; it may be split further as needed to allow sufficient sensor separation.

The sensors may be through-mounted to a wall using the hardware included with the sensors. Using the provided 8 mm long screws, SP3 sensors may mount to a maximum wall thickness of 4.0 mm (0.16"); SP8 sensors may mount to a maximum wall thickness of 3.2 mm (0.13"). If mounted to the threaded accessory mounting bracket, only the screws need be used.

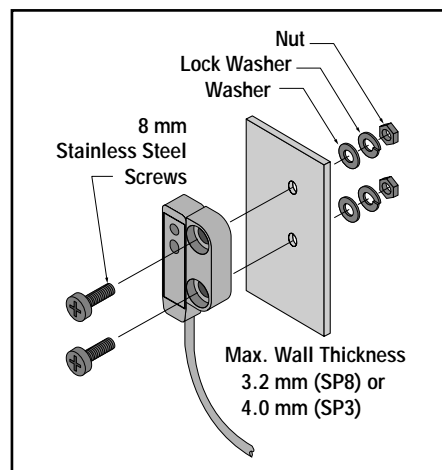

Figure 3. Mounting the SP3/SP8 sensor to a wall

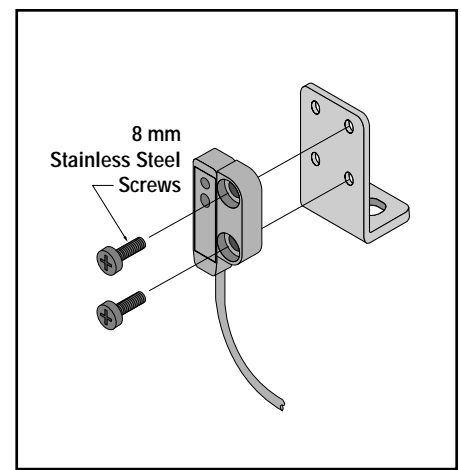
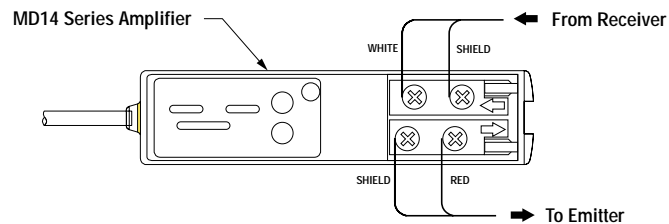

Figure 4. Mounting the SP3/SP8 sensor to its accessory mounting bracket (see page 7)

SP3/SP8 Remote Sensor Hookups



PICO-AMP Miniature Remote Sensing System

Accessories

Quick-Disconnect Cables

Cable: PUR jacket, polyurethane connector body, POM snap-lock coupling
Conductors: 26 or 24 AWG high-flex stranded, gold-plated contacts
Temperature: -40 to +90°C (-40 to +194°F)
Voltage Rating: 30V ac/36V dc

Style	Model	Length	Dimensions	Pin-out
4-Pin Pico-style Straight	PKG4-2	2 m (6.5')		
4-Pin Pico-style Right-angle	PKW4-2	2 m (6.5')		

Mounting Bracket

Model	Description
SMBSP3 304 Stainless Steel, 18 Gauge	



35 mm DIN Rail Track

Metal track, 35 mm wide, in a variety of lengths to accommodate multiple components.

Model	Description	
DIN-35-70	70 mm track, accommodates up to 4 MD14 Amplifiers	
DIN-35-105	105 mm track, accommodates up to 6 MD14 Amplifiers	
DIN-35-140	140 mm track, accommodates up to 8 MD14 Amplifiers	

WARRANTY: Banner Engineering Corp. warrants its products to be free from defects for one year. Banner Engineering Corp. will repair or replace, free of charge, any product of its manufacture found to be defective at the time it is returned to the factory during the warranty period. This warranty does not cover damage or liability for the improper application of Banner products. This warranty is in lieu of any other warranty either expressed or implied.