



RE46C108

Piezoelectric Horn Driver and Voltage Regulator
Product Specification

General Description

The RE46C108 is a piezoelectric horn driver with a voltage regulator that can operate at 3.3V or 5V. It is intended for applications requiring a 9V horn driver with a low voltage logic supply. The horn feedback control pin is designed for use with self-oscillating piezoelectric horn but can also be used in direct drive applications.

Applications

Smoke detectors
CO Detectors
Personal Security Products
Electronic Toys

Features

- Low Quiescent Current
- Low Horn Driver Ron
- Voltage Regulation to 3.3V or 5V
- Available in DIP and SOIC packaging
- Available in Standard Packaging or RoHS Compliant Pb Free Packaging

Pin Configuration

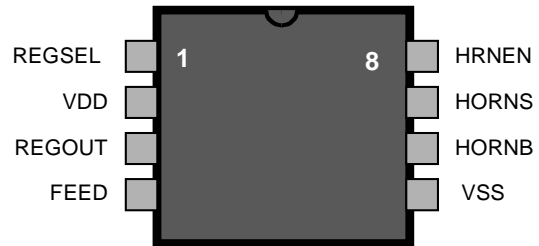

Absolute maximum ratings

Supply Voltage V_{DD}	-5V to +14V
Input voltage Range V_{in}	-.3V to $V_{DD}+3V$, except FEED
FEED Input Voltage Range V_{inf}	-10V to +22V
Input Current I_{in}	10mA, except FEED
Operating Temperature	-40 to 85°C
Continuous Output Current (HornS, HornB)	30mA
Continuous Output Current (REGOUT)	55mA

Stresses beyond those listed under Absolute Maximum Ratings may cause permanent damage to the device. These are stress ratings only and operation at these conditions for extended periods may affect device reliability.

This product utilizes CMOS technology with static protection; however proper ESD prevention procedures should be used when handling this product. Damage can occur when exposed to extremely high static electrical charges

RE46C108

Piezoelectric Horn Driver and Voltage Regulator
Product Specification



R&E International

Electrical Characteristics at $T_A = 25^\circ\text{C}$, $V_{DD} = 9\text{V}$, $V_{SS} = 0\text{V}$ (unless otherwise noted).

Parameter	Test Pin	Test Conditions	Limits			Units
			Min	Typ	Max	
Supply Voltage	Vdd	Operating	6.0	9.0	13.8	V
Standby Supply Current	Vdd	Hrnen=Vss; No Loads			4	μA
Input Leakage	Hrnen,Resel	Vin=Vdd or Vss	-100		100	nA
	FEED	Feed = +22V		20	50	μA
	FEED	Feed = -10V	-50	-15		μA
Input Voltage Low	Hrnen, Regsel			1.0	V	
Input Voltage High	Hrnen, Regsel		2.3		V	
Output Low Voltage	Horns or Hornb	Iout=16mA; Vdd=9V Vdd=7.2V		0.3	0.5	V
					0.9	V
Output High Voltage	Horns or Hornb	Iout=-16mA; Vdd=9V Vdd=7.2V	8.5	8.7		V
			6.3			V
Regulator Voltage	Regout	Iout<50mA; Regsel=Vdd Iout<50mA; Regsel=Vss $T_A=-40$ to 85°C See note #3	4.75	5.0	5.25	V
			3.10	3.3	3.50	V
Line Regulation	Regout	$6\text{V} < V_{DD} < 12\text{V}$; No load		30		mV
Load Regulation	Regout	$0\text{mA} < I_{out} < 20\text{mA}$		100		mV
Brown-Out Threshold Voltage *See note #1	Vdd	Regsel=Vdd or Vss Falling edge of Vdd	4.5	5.0	5.5	V
Brown-Out Pull Down Current	Regout	Vdd=4.5V; Regout=2V	15	25		mA
Regout Overvoltage Clamp *See note #2	Regout	Regsel=Vdd; Iout > 1mA Regsel=Vss; Iout > 1mA	5.5	6.0	6.5	V
			3.7	4.0	4.3	V

Notes:

1/ The brown-out threshold voltage is the Vdd voltage at which the regulator will be disabled and Regout will be pulled to Vss.

2/ In normal operation, the regulator will provide high-side current of up to 20mA, but current sinking capability is typically under 1 μA . The overvoltage clamp is intended to limit the voltage at Regout when it is pulled up by an external source.

3/ The limits shown are 100% tested at 25C only. Test limits are guard-banded based on temperature characterization to guarantee compliance at temperature extremes.

RE46C108

Piezoelectric Horn Driver and Voltage Regulator
Product Specification



R&E International

Typical Application

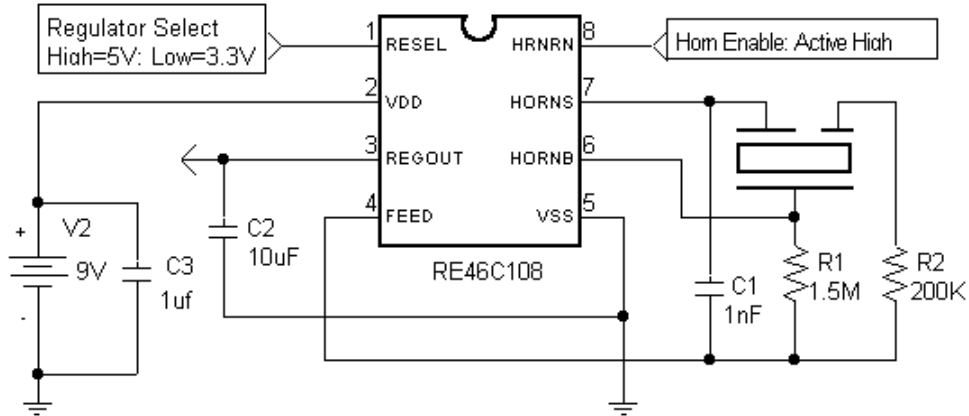

Typical Application Using Self Resonating Piezoelectric Horn

Functional Block Diagram

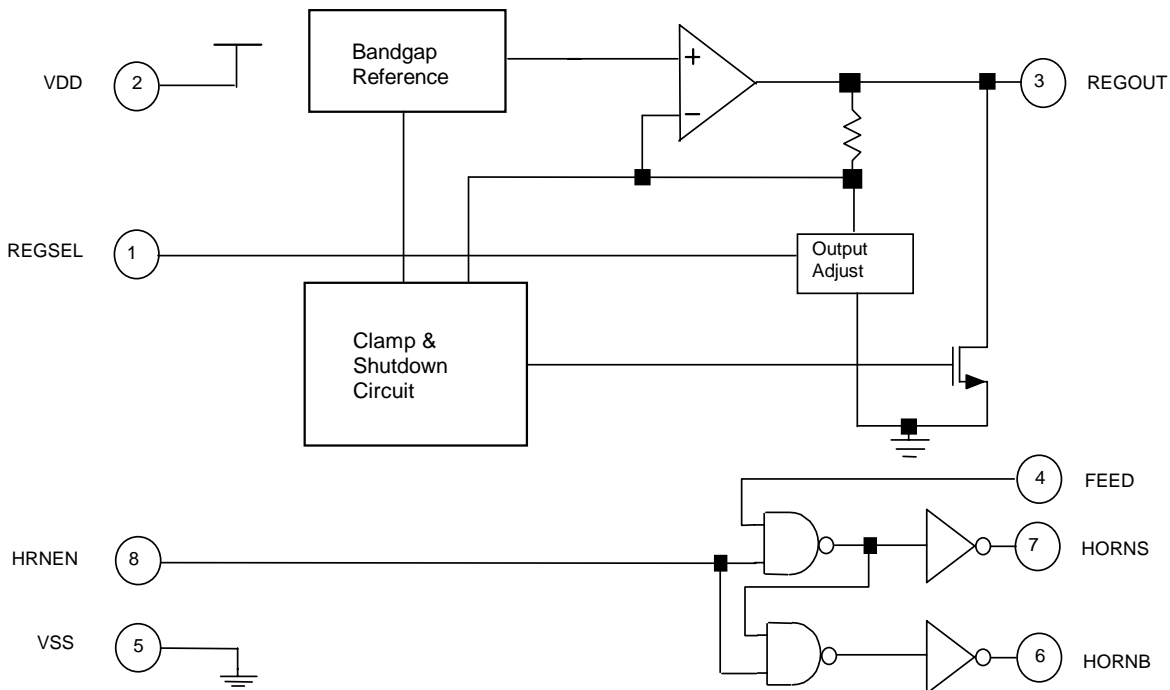

RE46C108

Piezoelectric Horn Driver and Voltage Regulator
Product Specification



R&E International

R&E INTERNATIONAL, Inc. reserves the right to make changes without further notice to any products herein to improve reliability, function or design.

R&E INTERNATIONAL, Inc. does not assume any liability arising out of the application or use of any product or circuit described herein; neither does it convey any license under its patent rights, nor the rights of others.

R&E INTERNATIONAL, Inc. products are not authorized for use as critical components in life support devices or systems without the express written approval of the President of R&E INTERNATIONAL, Inc. Life support devices or systems are devices or systems which are intended for surgical implant into the body to support or sustain life, and whose failure to perform, when properly used in accordance with instructions for use provided in the labeling, can be reasonably expected to result in a significant injury to the user. A critical component is any component of a life support device or system whose failure to perform can be reasonably expected to cause the failure of the life support device or system, or to affect its safety or effectiveness.