

**DESCRIPTION**

The LX8821 is a positive-voltage linear regulator with one fixed and one adjustable output featuring low-dropout and high accuracy.

To maximize efficiency, the LX8821 accepts two supply voltage inputs for the  $V_{CONTROL}$  and  $V_{POWER}$  sections. This configuration reduces power dissipation by operating the regulator near dropout ( $V_{PWR} - V_{OUT} = VDO = 0.4V @ 2A$ ) while providing sufficient operating headroom for the control logic.

Each channel can supply up to 2.5A independently with a regulator design optimized for system efficiency by consuming minimal ground current and directing quiescent current to the load.

The internal voltage reference is trimmed at wafer level, enabling precise output voltages, typically  $\pm 1\%$  of its specified value.

Power sequencing logic ensures proper startup regardless of the level of  $V_{CTRL}$  or  $V_{PWR}$ . The LX8821 outputs remain off while  $V_{PWR} < 2.2V$ .

Thermal and Short Circuit Current Protection are integrated on-chip and operate independently for each regulator output.

The LX8821 regulator is stable with a wide range of output capacitance and ESR; typically 10 $\mu$ F tantalum or ceramic on the outputs is sufficient.

Microsemi uses a low profile power package with low thermal resistance and ease of assembly using surface mount technology.

**KEY FEATURES**

- Two Independent Regulated Outputs
- Wide DC Supply Voltage of 3.0V to 10.0V
- Accurate Output Voltages
- Low Tolerance Line (0.5%) and Load (0.5%) Regulation
- Max. Dropout of 0.6V at Rated Current
- Independent Thermal and Current Limit Protection
- Loop Stability Independent of Output Capacitor
- Type SMT Power Package

**APPLICATIONS/BENEFITS**

- ASIC, Memory, I/O
- Low Voltage Logic Supplies
- Active SCSI Terminators
- Battery Charging Circuits
- PC Peripherals
- Instrumentation

IMPORTANT: For the most current data, consult Microsemi's website: <http://www.microsemi.com>

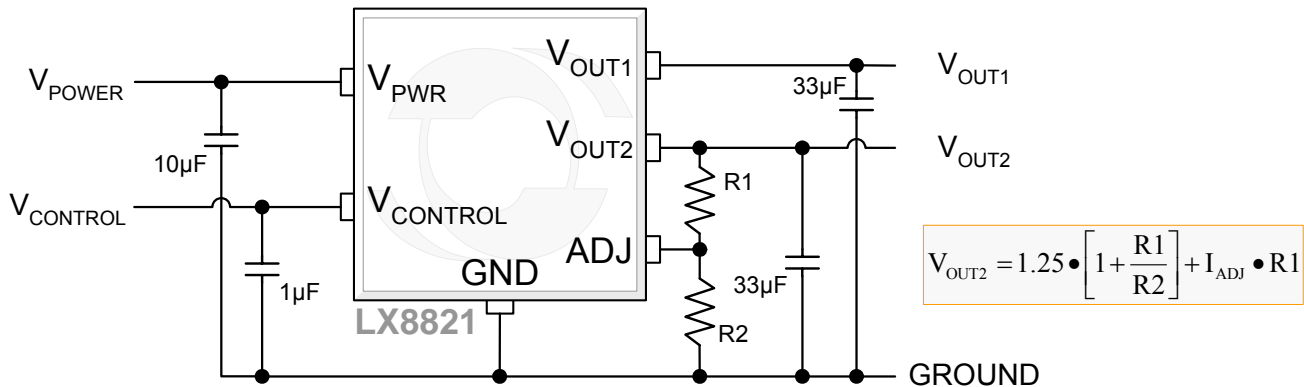
**PRODUCT HIGHLIGHT**

**PACKAGE ORDER INFO**

$T_A$ (°C)	Output V1	Output V2	<b>DF</b> Plastic S-Pak 7-Pin RoHS Compliant
0 to 100	1.5V	Adjustable	<b>LX8821CDF</b>

Note: Available in Tape & Reel. Append the letters "TR" to the part number. (i.e. LX8821CDF-TR)

**ABSOLUTE MAXIMUM RATINGS**

Input Voltage ( $V_{CTRL}$ , $V_{PWR}$ ).....	13.5V
Load Current (Internally Limited) .....	3.0A
Power Dissipation .....	Internally Limited
Short-Circuit Protection .....	Indefinite
Operating Junction Temperature.....	150°C
Storage Temperature Range.....	-65°C to 150°C
Peak Package Solder Reflow Temperature (40 second maximum exposure) .....	260°C (+0, -5)

Note: Exceeding these ratings could cause damage to the device. All voltages are with respect to Ground. Currents are positive into, negative out of specified terminal.

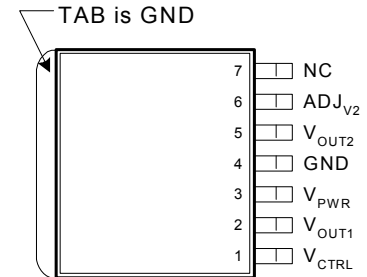
**PACKAGE PIN OUT**

**DF PACKAGE**  
(Top View)

Pin 4 and Tab are common

RoHS 100% Matte Tin Lead Finish

**THERMAL DATA**
**DF Plastic S-Pak 7-Pin**

THERMAL RESISTANCE-JUNCTION TO TAB, $\theta_{JT}$	<b>4.5°C/W</b>
THERMAL RESISTANCE-JUNCTION TO AMBIENT, $\theta_{JA}$	<b>20 - 50°C/W</b>

Junction Temperature Calculation:  $T_J = T_A + (P_D \times \theta_{JA})$ .  
 The  $\theta_{JA}$  numbers are guidelines for the thermal performance of the device/pc-board system.  
 All of the above assume no ambient airflow.  $\theta_{JA}$  can vary from 10°C/W to > 50°C/W depending on mounting technique. (See Application Notes Section: Thermal considerations)

**FUNCTIONAL PIN DESCRIPTION**

PIN	NAME	DESCRIPTION
1	$V_{CTRL}$	Unregulated input voltage supply, provides bias for control circuitry, ( $V_{CTRL} - V_{OUT}$ ) > 1V.
2	$V_{OUT1}$	Regulator #1 fixed output voltage, 1.5V nominal.
3	$V_{PWR}$	Unregulated input voltage supply for power section. For proper operation: ( $V_{PWR} - V_{OUT}$ ) > $V_{DROPOUT}$ .
4	GND	Common terminal for ground reference, Tab of package is internally connected to this pin.
5	$V_{OUT2}$	Regulator #2 output
6	ADJ $V_2$	Regulator #2 feedback voltage, servos to 1.25V. Using external resistors to program $V_{OUT2}$ .
7	---	Not used, no internal connection, may be left floating or connected to any other pin or voltage.

**ELECTRICAL CHARACTERISTICS**

Unless otherwise specified, the following specifications apply over the operating ambient temperature  $0^{\circ}\text{C} \leq T_A \leq 100^{\circ}\text{C}$  except where otherwise noted and the following test conditions:  $V_{\text{CTRL}} = 5\text{V}$ ,  $V_{\text{PWR}} = 3.3\text{V}$ ,  $I_{\text{OUT}} = 5\text{mA}$ ,  $C_{1,2,3,4} = 10\mu\text{F}$  (Tantalum), and  $T_J = T_A$  using low duty cycling methods. Typical values represent performance @  $23^{\circ}\text{C}$

Parameter	Symbol	Test Conditions	LX8821			Units
			Min	Typ	Max	
<b>▶ FIXED OUTPUT: <math>V_{\text{OUT}1}</math></b>						
Total Output Voltage Variation	$V_1$	$5\text{mA} < I_1 < 2.5\text{A}$ , $3.75\text{V} < V_{\text{CTRL}} < 8\text{V}$ $3.3\text{V} < V_{\text{PWR}} < 5.5\text{V}$	1.455	1.500	1.545	V
Line Regulation	$\Delta V_1(V_{\text{IN}})$	$3.3\text{V} < V_{\text{CTRL}} < 10\text{V}$ , $3.3\text{V} < V_{\text{PWR}} < 5.5\text{V}$ , $I_1 = 5\text{mA}$		1	5	mV
Load Regulation	$\Delta V_1(I_1)$	$5\text{mA} < I_1 < 2.5\text{A}$ , $V_{\text{CTRL}} = 5\text{V}$ , $V_{\text{PWR}} = 3.3\text{V}$		1	5	mV
Current Limit	$I_{1(\text{MAX})}$		2.55	3.0		A
Minimum Load Current	$I_1$	Note 1		0	5	mA
<b>▶ ADJUSTABLE OUTPUT: <math>V_{\text{OUT}2}</math></b>						
Output Voltage	$V_2$	$5\text{mA} < I_2 < 2.5\text{A}$ , $3.75\text{V} < V_{\text{CTRL}} < 8\text{V}$ $2.97\text{V} < V_{\text{PWR}} < 3.63\text{V}$	1.225	1.25	1.275	V
		$5\text{mA} < I_2 < 2.5\text{A}$ , $3.75\text{V} < V_{\text{CTRL}} < 8\text{V}$ , $3.3\text{V} < V_{\text{PWR}} < 5.5\text{V}$	1.225	1.25	1.288	
Line Regulation	$\Delta V_2(V_{\text{IN}})$	$3.3\text{V} < V_{\text{CTRL}} < 10\text{V}$ , $3.3\text{V} < V_{\text{PWR}} < 5.5\text{V}$ , $I_2 = 5\text{mA}$		0.5	5	mV
Load Regulation	$\Delta V_2(I_2)$	$5\text{mA} < I_2 < 2.5\text{A}$ , $V_{\text{CTRL}} = 5\text{V}$ , $V_{\text{PWR}} = 3.3\text{V}$		8	20	mV
Dropout Voltage, $V_{\text{OUT}2}$	$V_{\text{PWR}} - V_2$	$I_{\text{OUT}} = 2.5\text{A}$ , $\Delta V_{\text{O}} = -2\%$		0.500	0.750	V
		$I_{\text{OUT}} = 2.0\text{A}$ , $\Delta V_{\text{O}} = -2\%$		0.413	0.600	
		$I_{\text{OUT}} = 1.0\text{A}$ , $\Delta V_{\text{O}} = -2\%$		0.167	0.400	
	$V_{\text{CNTR}} - V_2$	$I_{\text{OUT}} = 2.5\text{A}$ , $\Delta V_{\text{O}} = -2\%$		0.95	1.10	V
$I_{\text{OUT}} = 1.0\text{A}$ , $\Delta V_{\text{O}} = -2\%$			0.80	1.00		
Adjust Pin Current		$I_1 = I_2 = 5\text{mA}$ , $T_J = 25^{\circ}\text{C}$		0.2	1	$\mu\text{A}$
Current Limit	$I_{2(\text{MAX})}$		2.55	3.0		A
Minimum Load Current	$I_2$	Note 1		1	5	mA
<b>▶ ENTIRE REGULATOR</b>						
Minimum Operating Voltage	$V_{\text{PWR}}$				2.6	V
	$V_{\text{CONTROL}}$				3.3	V
Under Voltage Lockout		$V_{\text{PWR}}$ Rising, $3.0\text{V} < V_{\text{CTRL}} < 10\text{V}$ , Both Outputs Guaranteed Off			2.2	V
Quiescent Current	$I_{\text{Q}}$	$I_1 = I_2 = 5\text{mA}$		3	5	mA
		$I_1 = I_2 = 2.5\text{A}$		5	10	mA
Ripple Rejection	PSRR	$f = 120\text{Hz}$ , $T_J = 25^{\circ}\text{C}$	60	75		dB
RMS Output Noise		$10\text{Hz} < f < 10\text{kHz}$		0.003		$\%V_{\text{OUT}}$
Thermal Shutdown	$T_{\text{JSD}}$			160		$^{\circ}\text{C}$

Note 1: Minimum load current is defined as the amount of output current required to maintain regulation

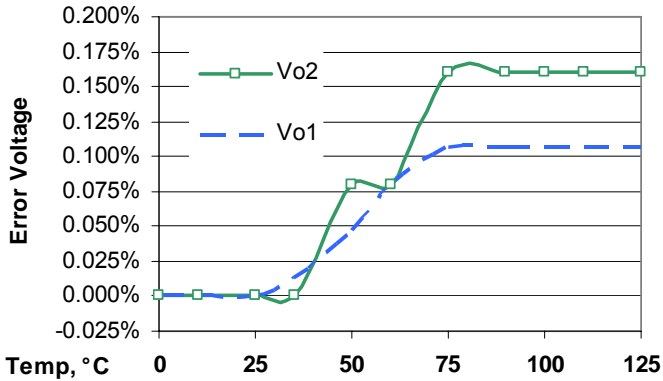
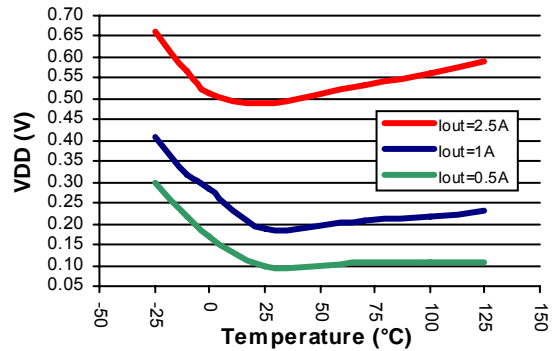
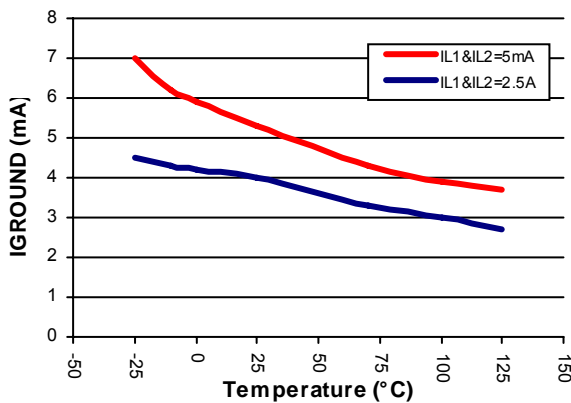
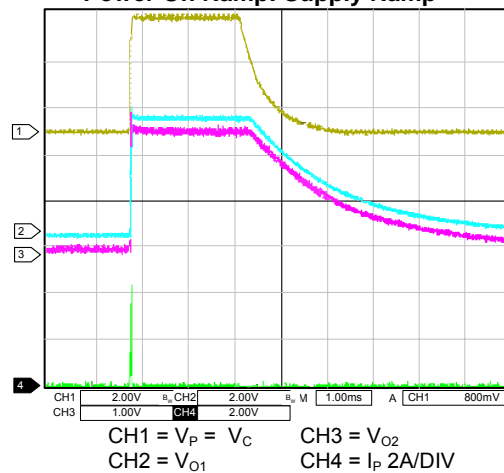
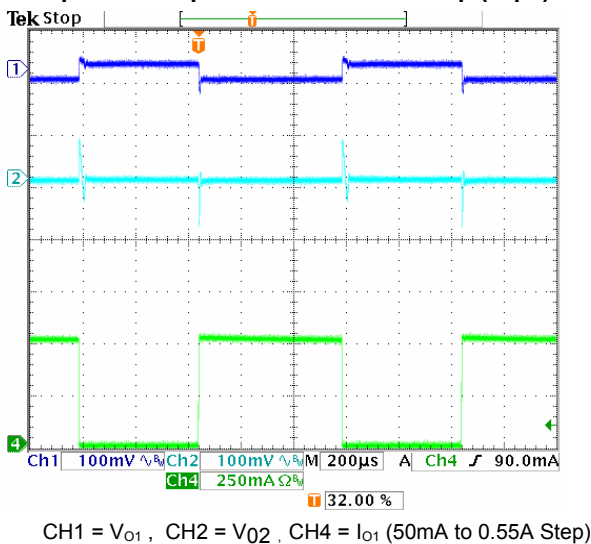
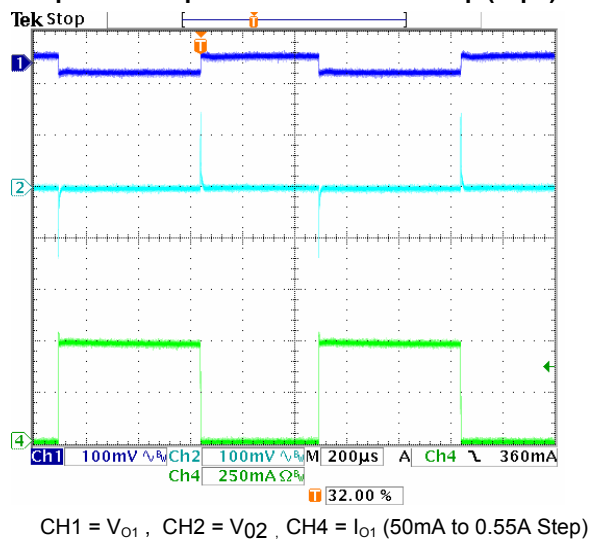
**CHARACTERISTIC CURVES**
**V<sub>OUT</sub> Error vs. Temperature**

**Dropout Voltage**

**Quiescent Current**

**Power On Ramp: Supply Ramp**

**Step Load Response With Ceramic Cap (10µF)**

**Step Load Response With Tantalum Cap (10µF)**

**APPLICATION INFORMATION**

The LX8821 is part of a family of Dual LDO (Low Drop-Out) linear regulators in Microsemi's S-PAK power package which offer maximum power dissipation in a low profile surface mount technology. The family includes combination fixed and adjustable versions. Each channel can supply up to 2.5A independently with a regulator design optimized for system efficiency by consuming minimal ground current and directing quiescent current to the load.

**INPUT CAPACITOR**

To improve load transient response and noise rejection an input bypass capacitor is of at least 10 $\mu$ F is required. Generally we recommend a 10 $\mu$ F ceramic or tantalum or 22 $\mu$ F electrolytic capacitor.

**OUTPUT CAPACITOR**

The regulator requires output capacitors connected between each output (V1, V2) to GND to stabilize the internal control loop. Many types of capacitors are available, with different capacitance values tolerances, temperature coefficients and equivalent series resistance. We recommend a minimum of 10 $\mu$ F. To ensure good transient response from the power supply system under rapidly changing current load conditions, designers generally use additional output capacitors connected in parallel. Such an arrangement serves to minimize the effects of the parasitic resistance (ESR) and inductance (ESL) that are present in all capacitors. The regulator has been tested stable with capacitor ESR's in the range of 0.05 to 2 ohms. We have found it best to use the same type of capacitor for both input and output bypass.

**ADJUSTABLE OUTPUT VOLTAGE**

The LX8821 develops a 1.25V reference voltage between the adjust terminal and GND (See Figure 2). By placing a resistor, R2, between these two terminals, a constant current is caused to flow through R1 and down through R2 to set the overall output voltage. Because I<sub>ADJ</sub> is very small and constant when compared with the current through R2, it represents a small error and can usually be ignored.

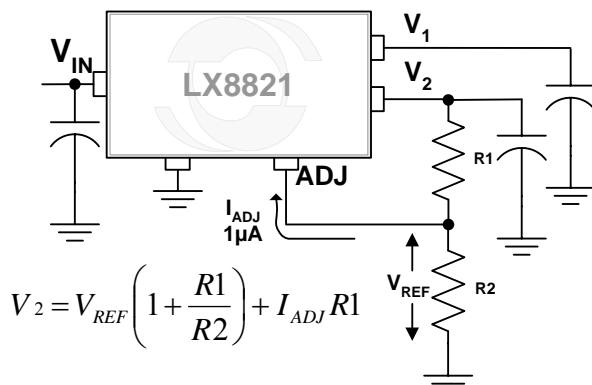

**Figure 2 – Basic Adjustable Regulator**

**MINIMUM LOAD REQUIREMENT**

The LX8821 has a minimum load requirement for proper output regulation. This typical current is specified at 0mA for the fixed output and 1ma for the adjustable output regulators.

**TEMPERATURE PROTECTION**

The thermal protection shuts the LX8821 down when the junction temperature exceeds 160°C. Each output has independent thermal shutdown capability. Exposure to absolute maximum rated conditions for extended periods may affect device reliability: see Thermal Considerations below.

**CURRENT LIMIT PROTECTION**

The LX8821 includes over current protection; when the output load current exceeds typically 3A the circuit forces the regulator decrease in output.

**THERMAL CONSIDERATIONS**

Thermal shutdown protects the integrated circuit from thermal overload caused from a rise in junction temperature during power dissipation. This means of protection is intended for fault protection only and not as a means of current or power limiting during normal application usage. Proper thermal evaluation should be done to ensure that the junction temperature dose not exceed it's maximum rating. Operating at the maximum T<sub>J</sub> of 150°C can impact reliability. Due to variation in individual device electrical characteristics and thermal resistance, the built in thermal overload protection may be activated at power levels slightly above or below the rated dissipation. Also peak output power should be considered for each individual output.

Power dissipation for regulator can be calculated using the following equation:

$$P_D = (V_{IN(MAX)} - V_1) \times I_1 + (V_{IN(MAX)} - V_2) \times I_2$$

(Note: power dissipation resulting from quiescent (ground) current is negligible)

Thermal resistance,  $\theta_{TAB-AMB}$  ranges from 25-45°C/W depending on mounting technique using a FR4 copper clad PCB. Junction temperature of the integrated circuit can be calculated using:

$$T_{JUNCTION} = T_{JUNCTION-TAB} + T_{TAB-AMB} + T_{AMB}$$

$$T_{TAB} = P_{D(MAX)} \times \theta_{JT} ; T_{TAB-AMB} = (P_{DREG1} + P_{DREG2}) \times \theta_{PCB}$$

An example: Given conditions: T<sub>A</sub> = 50°C, V<sub>IN</sub> = 5.0V, V<sub>1</sub> = 1.5V, I<sub>1</sub> = 210mA, V<sub>2</sub> = 3.3V I<sub>2</sub> = 1A.

Calculated values:

$$T_{J-TABREG1} = (5V - 1.5V) \times (0.21A) \times 4.5^\circ C/W = (0.735) \times 4.5^\circ C/W = 3.3^\circ C$$

$$T_{J-TABREG2} = (5V - 3.3V) \times (1A) \times 4.5^\circ C/W = (1.7) \times 4.5^\circ C/W = 7.7^\circ C$$

$$T_{TAB-AMB} = (0.735W + 1.7W) \times 30^\circ C/W = 73.1^\circ C$$

$$T_{JUNCTION-MAX} = 7.7^\circ C + 73.1^\circ C + 50^\circ C = 130.8^\circ C$$

It is important to note that although each output of the regulator will produce up to 2.5A in current, the individual or total power dissipation may limit the useful total current draw. The junction temperature should be calculated for each individual output as well as the combined outputs to insure the maximum junction temperature is not exceeded.

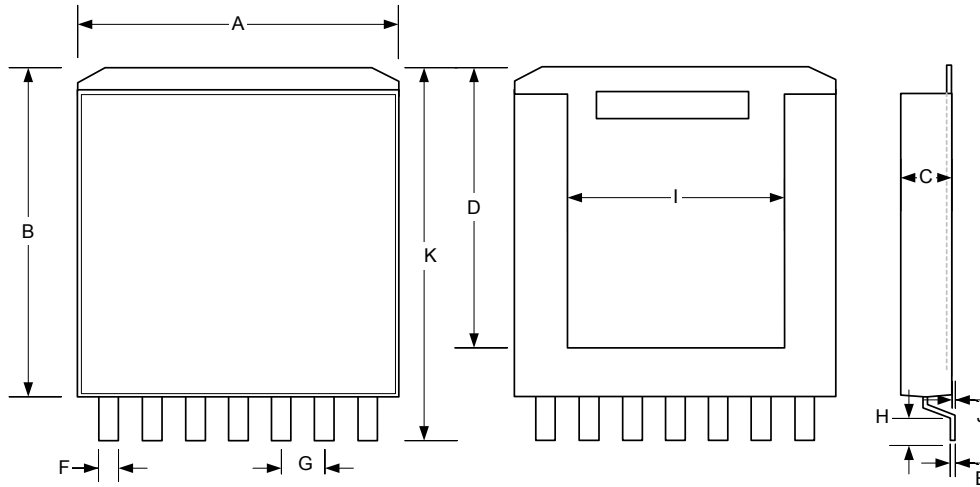
**MECHANICAL DIMENSIONS**

**Note:** 1. Dimensions do not include mold flash or protrusions; these shall not exceed 0.155mm(.006") on any side. Lead dimension shall not include solder coverage

Dim	MILLIMETERS		INCHES	
	MIN	MAX	MIN	MAX
A	9.27	9.52	.365	.375
B	8.89	9.14	.350	.360
C	1.77	2.03	.070	.080
D	7.49	7.74	.295	.305
E	0.12	0.38	.005	.015
F	0.58	0.84	.023	.033
G	1.27 BSC		0.050 BSC	
H	0.79	1.04	.031	.041
I	4.31	6.86	.170	.270
J	0.03	0.13	.001	.005
K	10.41	10.67	.410	.420

PRODUCTION DATA – Information contained in this document is proprietary to Microsemi and is current as of publication date. This document may not be modified in any way without the express written consent of Microsemi. Product processing does not necessarily include testing of all parameters. Microsemi reserves the right to change the configuration and performance of the product and to discontinue product at any time.