

CURRENT SENSING TRANSFORMER

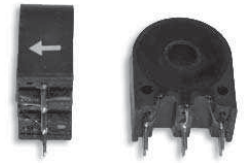

ACST-01-08, ACST-120-X

FEATURES:

- Precise Current Sensing
- UL94V0 Package

OPTIONS:

- Bulk packaging is standard
- Custom design available

APPLICATIONS:

- SMPS
- Current Sensing

STANDARD SPECIFICATIONS (Secondary Winding):

Part Number	OCL (mH Min)	Turns ($\pm 2\%$ Max)	DCR (Ω Max)	ET (V- μ Sec Max)	Schematic
ACST-001	5	50	0.7	150	A
ACST-002	20	100	1.4	300	A
ACST-003	80	200	4.5	600	A
ACST-004	180	300	11	900	A
ACST-005	5	50CT	0.7	150	B
ACST-006	20	100CT	1.4	300	B
ACST-007	80	200CT	4.5	600	B
ACST-008	180	300CT	11	900	B

TECHNICAL INFORMATION:

- Testing Frequency: 15.75KHz 0.1 VRMS
- Hipot: 2000VRMS, Primary to Secondary
- Maximum Sensing Current: 20A p-p
- All secondary measurements are pins 1-3

PHYSICAL CHARACTERISTICS:

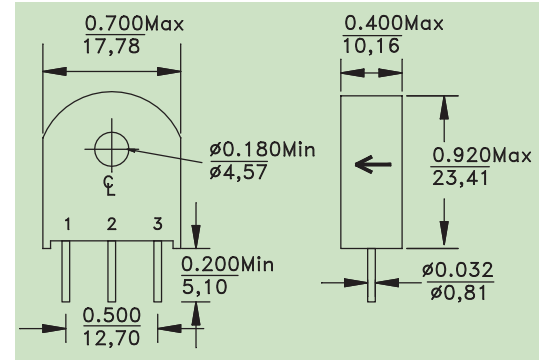
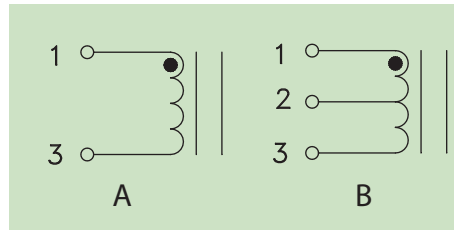

Part number	OCL (mH Min)	Turns ($\pm 2\%$ Max)	DCR (Ω Max)	Schematic
ACST-120-1	5	50	0.7	A
ACST-120-2	20	100	1.4	A
ACST-120-3	80	200	4.5	A
ACST-120-4	180	300	11	A
ACST-120-5	2000	1000	50	A
ACST-120-6	5	50CT	0.7	B
ACST-120-7	20	100CT	1.4	B
ACST-120-8	80	200CT	4.5	B
ACST-120-9	180	300CT	11	B
ACST-120-10	2000	1000CT	50	B
ACST-120-10A	2000	2000	110	A

TECHNICAL INFORMATION:

- Hipot: 2000VRMS, Primary to Secondary
- All secondary measurements are pins 1-3
- Turns ratio (Secondary to Primary) for CT: $\pm 2\%$
- Max sensing current @ 20AP-P
- OCL test at 60Hz, 1.0VRMS

PHYSICAL CHARACTERISTICS:

