

50 Amp Schottky Rectifier

SBR5090PF — SBR50100PF

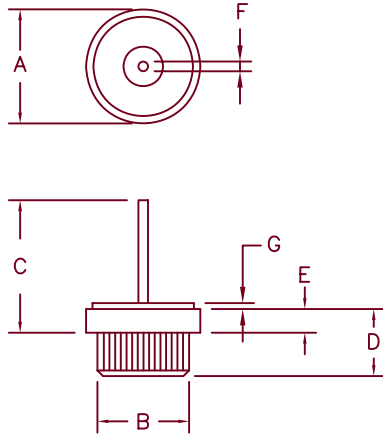

Dim.	Inches		Millimeter		Notes
	Minimum	Maximum	Minimum	Maximum	
A	.590	.630	14.98	16.00	Dia.
B	.499	.510	12.67	12.95	Dia.
C	1.15	1.40	29.21	15.20	
D	.320	.350	8.12	8.89	
E	.090	.096	2.29	2.44	
F	.047	.055	1.19	1.40	Dia.
G	.020	.038	.510	.970	

Microsemi Catalog Number	Working Peak Reverse Voltage	Repetitive Peak Reverse Voltage
SBR5090PF*	90V	90V
SBR50100PF*	100V	100V

* Add Suffix R for Reverse Polarity

- Schottky Barrier Rectifier
- Guard Ring Protected
- 175°C Junction Temperature
- VRRM – 90 to 100 Volts
- Reverse Energy Tested

Electrical Characteristics

Average forward current	$I_{F(AV)}$ 50 Amps	$T_C = 136^\circ\text{C}$, Square wave, $R_{\theta JC} = 1.0^\circ\text{C/W}$
Maximum surge current	I_{FSM} 800 Amps	8.3 ms, half sine, $T_J = 175^\circ\text{C}$
Max repetitive peak reverse current	$I_{R(OV)}$ 1 Amps	$f = 1 \text{ KHz}$, 25°C , 1 μsec Square wave
Max peak forward voltage	V_{FM} .89 Volts	$I_{FM} = 60\text{A}$; $T_J = 25^\circ\text{C}^*$
Max peak reverse current	I_{RM} 10 mA	V_{RRM} , $T_J = 125^\circ\text{C}^*$
Max peak reverse voltage	I_{RM} 1 mA	V_{RRM} , $T_J = 25^\circ\text{C}$
Typical junction capacitance	C_J 1300 pF	$V_R = 5.0\text{V}$, $T_J = 25^\circ\text{C}$

*Pulse test: Pulse width 300 μsec , Duty cycle 2%

Thermal and Mechanical Characteristics

Storage temp range	T_{STG}	-55°C to 175°C
Operating junction temp range	T_J	-55°C to 175°C
Max thermal resistance	$R_{\theta JC}$	1.0°C/W Junction to case
Weight		.32 ounces (9.2 grams) typical



6 Lake Street
Lawrence, MA 01841
PH: (978) 620-2600
FAX: (978) 689-0803
www.microsemi.com

05-25-07 Rev. 2

SBR5090PF — SBR50100PF

Figure 1
Typical Forward Characteristics

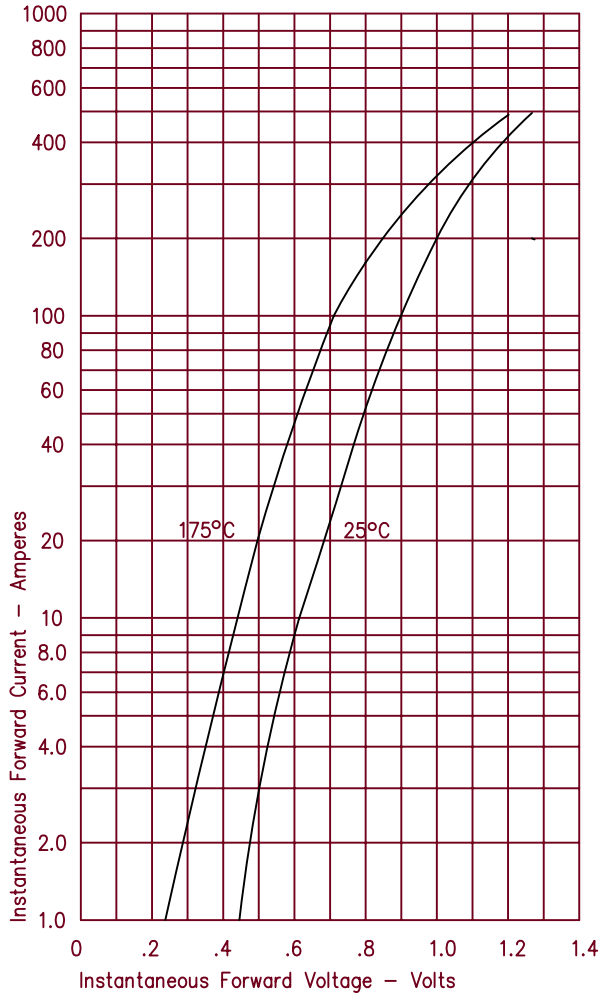

Figure 3
Typical Junction Capacitance

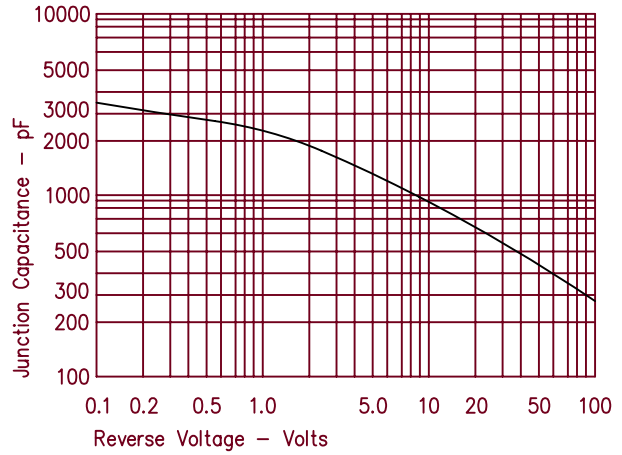

Figure 4
Forward Current Derating

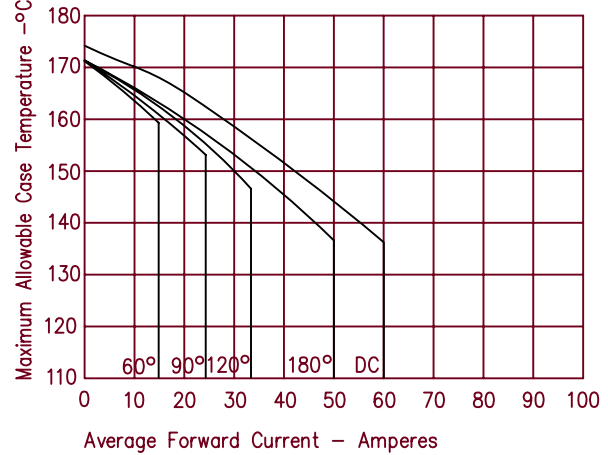

Figure 2
Typical Reverse Characteristics

