

**D3FS6****60V 3A****特長**

- 小型SMD
- PRISM アバランシェ保証

**Feature**

- Small SMD
- PRISM Rating

**用途**

- スイッチング電源
- DC/DCコンバータ
- 家電、ゲーム、OA機器
- 通信、ポータブル機器

**Main Use**

- Switching Regulator
- DC/DC Converter
- Home Appliance, Game, Office Automation
- Communication, Portable set

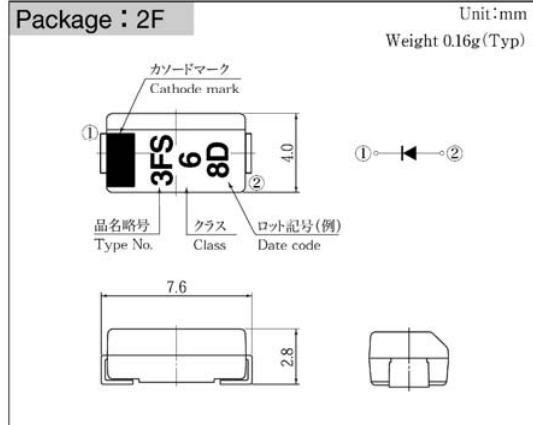
**■外観図 OUTLINE**

外形図については新電元Webサイト又は〈半導体製品一覧表〉をご参照下さい。捺印表示については捺印仕様をご確認下さい。

For details of the outline dimensions, refer to our web site or Semiconductor Short Form Catalog. As for the marking, refer to the specification "Marking, Terminal Connection".

**■定格表 RATINGS****●絶対最大定格 Absolute Maximum Ratings (指定のない場合  $T_I = 25^\circ\text{C}$ )**

項目 Item	記号 Symbol	条件 Conditions	品名 Type No.	D3FS6	単位 Unit
保存温度 Storage Temperature	$T_{stg}$			-55~150	$^\circ\text{C}$
接合部温度 Operation Junction Temperature	$T_j$			150	$^\circ\text{C}$
せん頭逆電圧 Maximum Reverse Voltage	$V_{RM}$			60	V
繰り返しせん頭サージ逆電圧 Repetitive Peak Surge Reverse Voltage	$V_{RRSM}$	パルス幅0.5ms, duty 1/40 Pulse width 0.5ms, duty 1/40		65	V
出力電流 Average Rectified Forward Current	$I_O$	50Hz正弦波, 抵抗負荷 50Hz sine wave, Resistance load	$T_a = 25^\circ\text{C}$ アルミナ基板実装 On alumina substrate $T_I = 87^\circ\text{C}$	1.65 3.0	A
せん頭サージ順電流 Peak Surge Forward Current	$I_{FSM}$	50Hz正弦波, 非繰り返し1サイクルせん頭値, $T_j = 25^\circ\text{C}$ 50Hz sine wave, Non-repetitive 1 cycle peak value, $T_j = 25^\circ\text{C}$		80	A
繰り返しせん頭サージ逆電力 Repetitive Peak Surge Reverse Power	$P_{RRSM}$	パルス幅10 $\mu\text{s}$ , $T_j = 25^\circ\text{C}$ Pulse width 10 $\mu\text{s}$ , $T_j = 25^\circ\text{C}$		330	W

**●電氣的・熱的特性 Electrical Characteristics (指定のない場合  $T_I = 25^\circ\text{C}$ )**

順電圧 Forward Voltage	$V_F$	$I_F = 3.0\text{A}$ , パルス測定 Pulse measurement		MAX 0.58	V
逆電流 Reverse Current	$I_R$	$V_R = V_{RM}$ , パルス測定 Pulse measurement		MAX 2.5	mA
接合容量 Junction Capacitance	$C_j$	$f = 1\text{MHz}$ , $V_R = 10\text{V}$		TYP 130	pF
熱抵抗 Thermal Resistance	$\theta_{jl}$	接合部・リード間 Junction to lead		MAX 24	$^\circ\text{C/W}$
	$\theta_{ja}$	接合部・周囲間 Junction to ambient	アルミナ基板実装 On alumina substrate プリント基板実装 On glass-epoxy substrate	MAX 90 MAX 124	

■特性図 CHARACTERISTIC DIAGRAMS

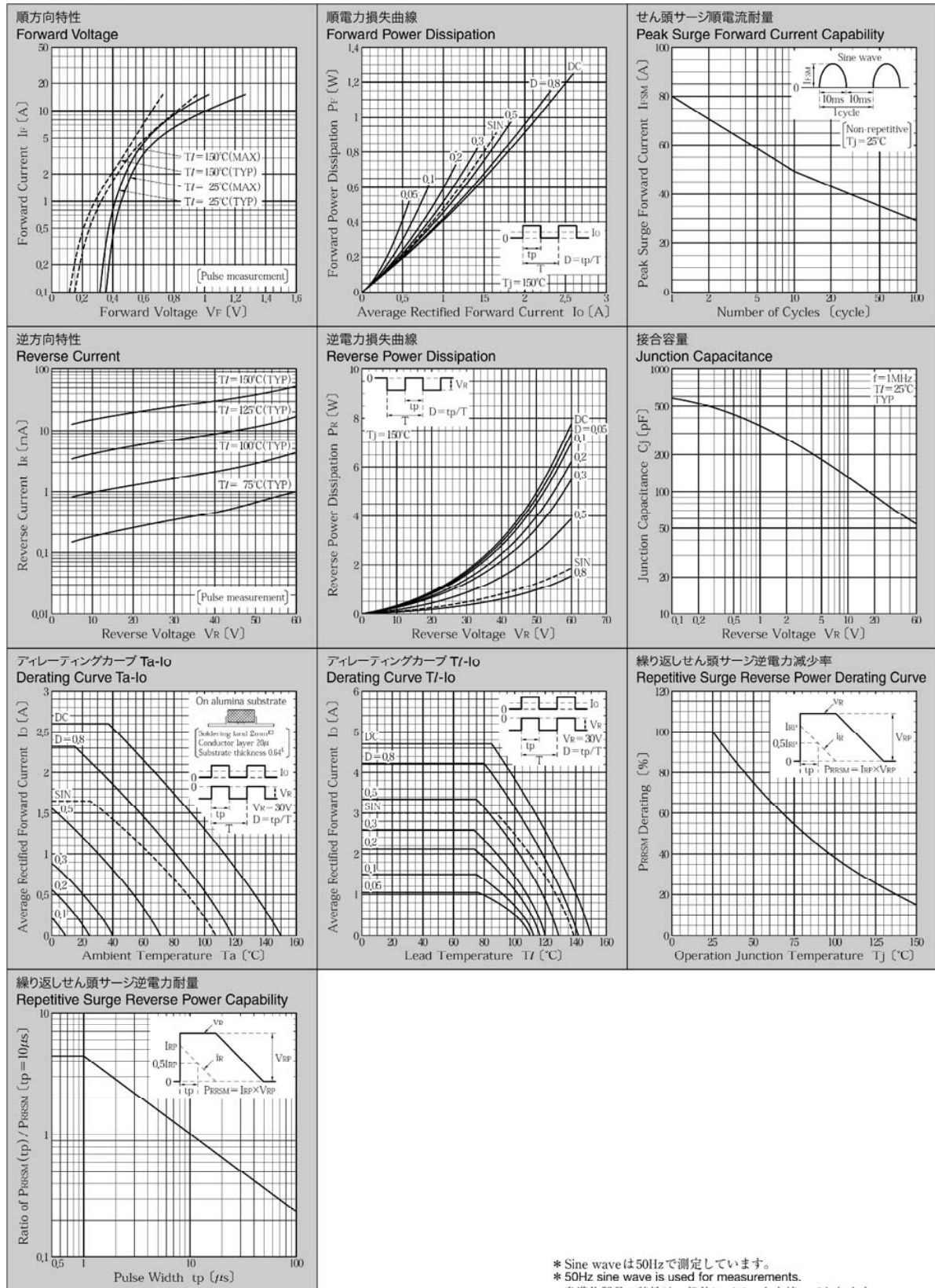

\* Sine waveは50Hzで測定しています。  
 \* 50Hz sine wave is used for measurements.  
 \* 半導体製品の特性は一般的にバラツキを持っており、Typicalは統計的な実力を表しています。  
 \* Semiconductor products generally have characteristic variation. Typical is a statistical average of the device's ability.