

M3FL20U**200V 3A****特長**

- 小型SMD
- 低ノイズ
- trr=35ns
- 低VF=0.95V

Feature

- Small SMD
- Low Noise
- trr=35ns
- Low VF=0.95V

用途

- スイッチング電源
- DC/DCコンバータ
- 家電、OA、照明
- 通信

Main Use

- Switching Regulator
- DC/DC Converter
- Home Appliance, Office Automation, Lighting
- Communication

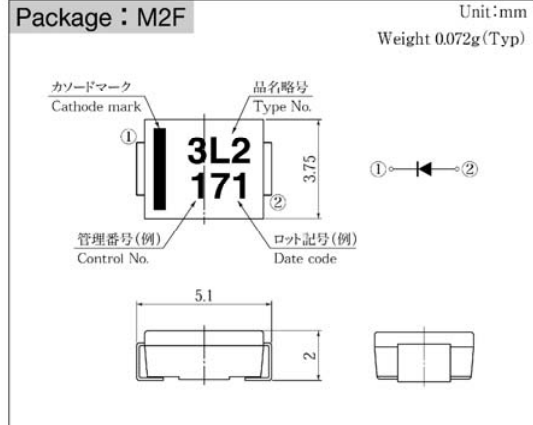
■外観図 OUTLINE

外形図については新電元Webサイト又は〈半導体製品一覧表〉をご参照下さい。捺印表示については捺印仕様をご確認下さい。
For details of the outline dimensions, refer to our web site or Semiconductor Short Form Catalog. As for the marking, refer to the specification "Marking, Terminal Connection".

■定格表 RATINGS**●絶対最大定格 Absolute Maximum Ratings (指定のない場合 $T_I = 25^\circ\text{C}$)**

項目 Item	記号 Symbol	条件 Conditions	品名 Type No.	M3FL20U	単位 Unit
保存温度 Storage Temperature	T _{stg}			-55~150	℃
接合部温度 Operation Junction Temperature	T _j			150	℃
せん頭逆電圧 Maximum Reverse Voltage	V _{RM}			200	V
出力電流 Average Rectified Forward Current	I _O	50Hz正弦波, 抵抗負荷 50Hz sine wave, Resistance load	T _I = 75℃ プリント基板実装 On glass-epoxy substrate	3	A
			T _a = 28℃ プリント基板実装 On glass-epoxy substrate	1.4	
せん頭サージ順電流 Peak Surge Forward Current	I _{FSM}	50Hz正弦波, 非繰り返し1サイクルせん頭値, T _j = 25℃ 50Hz sine wave, Non-repetitive 1 cycle peak value, T _j = 25℃		75	A

●電氣的・熱的特性 Electrical Characteristics (指定のない場合 $T_I = 25^\circ\text{C}$)

順電圧 Forward Voltage	V _F	I _F = 3A, パルス測定 Pulse measurement	MAX 0.95	V
逆電流 Reverse Current	I _R	V _R = V _{RM} , パルス測定 Pulse measurement	MAX 10	μA
逆回復時間 Reverse Recovery Time	trr	I _F = 0.5A, I _R = 1A	MAX 35	ns
接合容量 Junction Capacitance	C _j	f = 1MHz, V _R = 10V	TYP 58	pF
熱抵抗 Thermal Resistance	θ _{jl}	接合部・リード間 Junction to lead	MAX 25	℃/W
	θ _{ja}	接合部・周囲間, プリント基板実装 Junction to ambient, On glass-epoxy substrate	MAX 110	

■特性図 CHARACTERISTIC DIAGRAMS

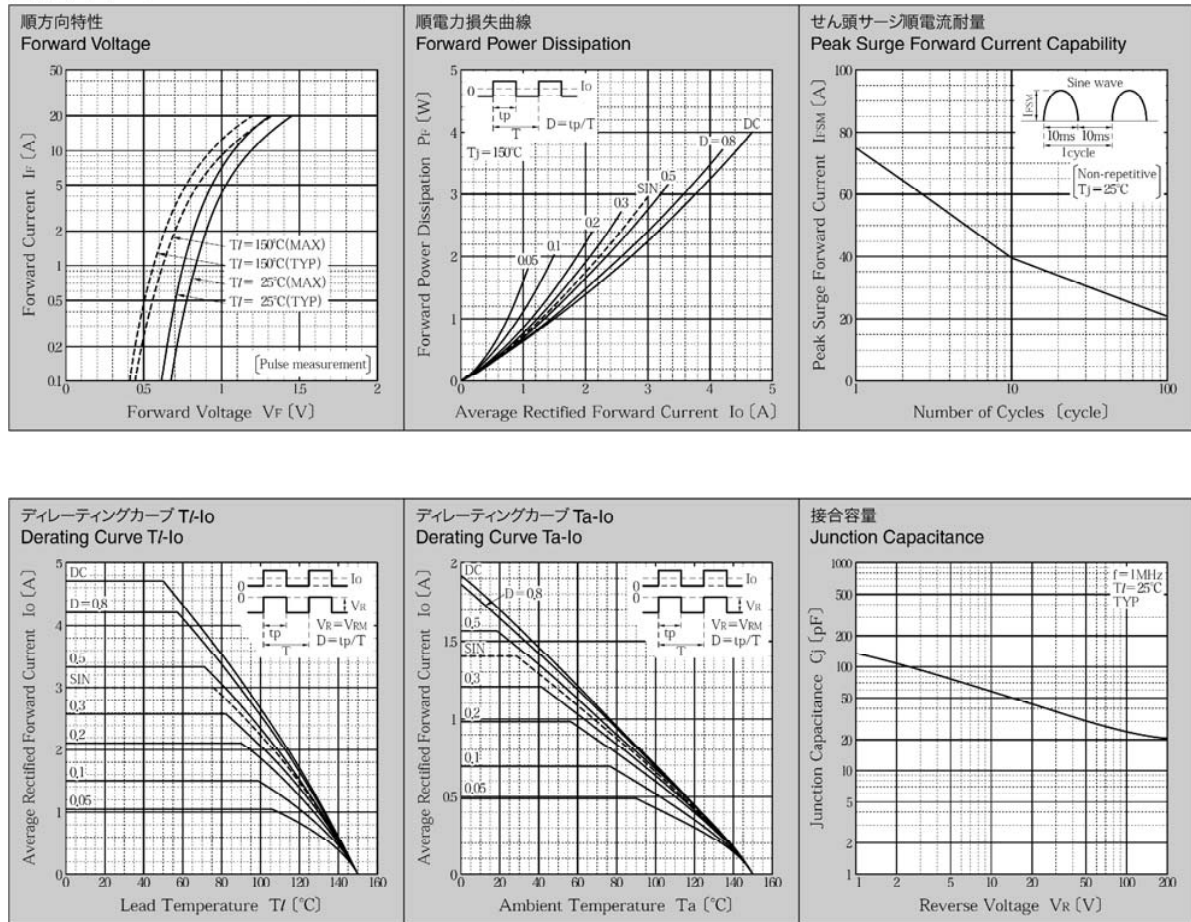

* Sine wave は50Hzで測定しています。
 * 50Hz sine wave is used for measurements.
 * 半導体製品の特性は一般的にバラツキを持っており、Typicalは統計的な実力を表しています。
 * Semiconductor products generally have characteristic variation. Typical is a statistical average of the device's ability.