

PLASTIC SILICON RECTIFIER

VOLTAGE RANGE: 50 --- 1000 V
CURRENT: 2.5 A

FEATURES

- ◇ Low cost
- ◇ Diffused junction
- ◇ Low leakage
- ◇ Low forward voltage drop
- ◇ High current capability
- ◇ Easily cleaned with Freon, Alcohol, Isopropanol and similar solvents
- ◇ The plastic material carries U/L recognition 94V-0

MECHANICAL DATA

- ◇ Case: JEDEC R-3, molded plastic
- ◇ Terminals: Axial lead, solderable per MIL-STD-202, Method 208
- ◇ Polarity: Color band denotes cathode end
- ◇ Weight: 0.021 ounces / 0.58 grams
- ◇ Mounting position: Any

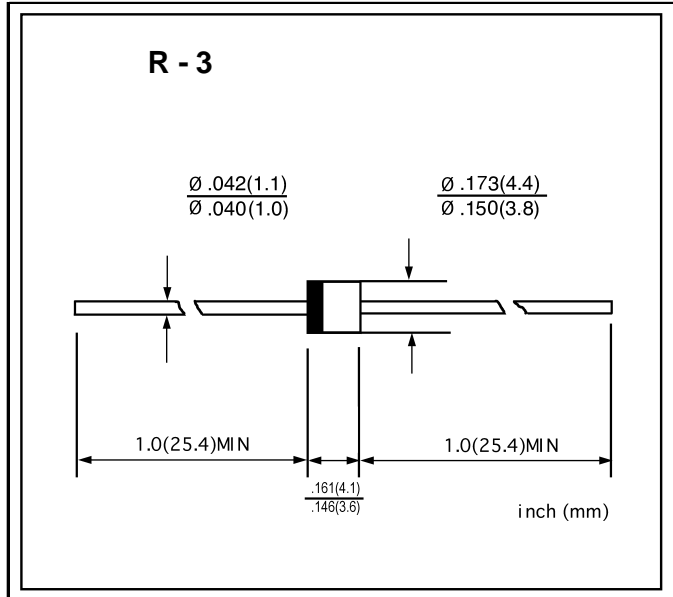

MAXIMUM RATINGS AND ELECTRICAL CHARACTERISTICS

Ratings at 25°C ambient temperature unless otherwise specified.

Single phase, half wave, 60 Hz, resistive or inductive load. For capacitive load, derate current by 20%.

		RL 251	RL 252	RL 253	RL 254	RL 255	RL 256	RL 257	UNITS
Maximum recurrent peak reverse voltage	V_{RRM}	50	100	200	400	600	800	1000	V
Maximum RMS voltage	V_{RMS}	35	70	140	280	420	560	700	V
Maximum DC blocking voltage	V_{DC}	50	100	200	400	600	800	1000	V
Maximum average forward rectified current 9.5mm lead length @ $T_A=75^\circ\text{C}$	$I_{F(AV)}$	2.5							A
Peak forward surge current 8.3ms single half-sine-wave superimposed on rated load @ $T_J=125^\circ\text{C}$	I_{FSM}	150.0							A
Maximum instantaneous forward voltage @ 2.5 A	V_F	1.1							V
Maximum reverse current @ $T_A=25^\circ\text{C}$ at rated DC blocking voltage @ $T_A=100^\circ\text{C}$	I_R	5.0 50.0							μA
Typical junction capacitance (Note1)	C_J	25							pF
Typical thermal resistance (Note2)	$R_{\theta JA}$	30							$^\circ\text{C/W}$
Operating junction temperature range	T_J	-55----+150							$^\circ\text{C}$
Storage temperature range	T_{STG}	-55----+150							$^\circ\text{C}$

NOTE: 1. Measured at 1.0MHz and applied reverse voltage of 4.0V DC.
2. Thermal resistance from junction to ambient.

www.galaxycn.com

FIG.1 – FORWARD DERATING CURVE

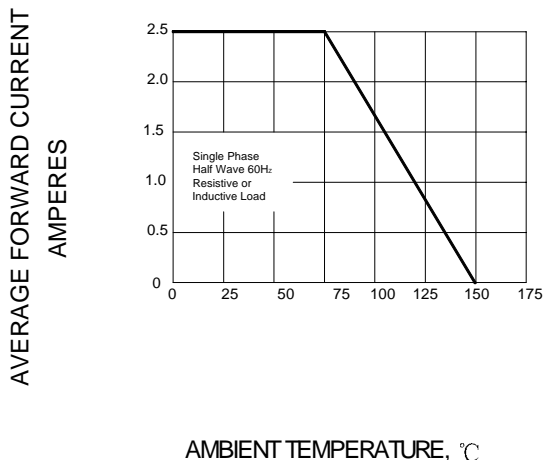

FIG.2 – TYPICAL FORWARD CHARACTERISTIC

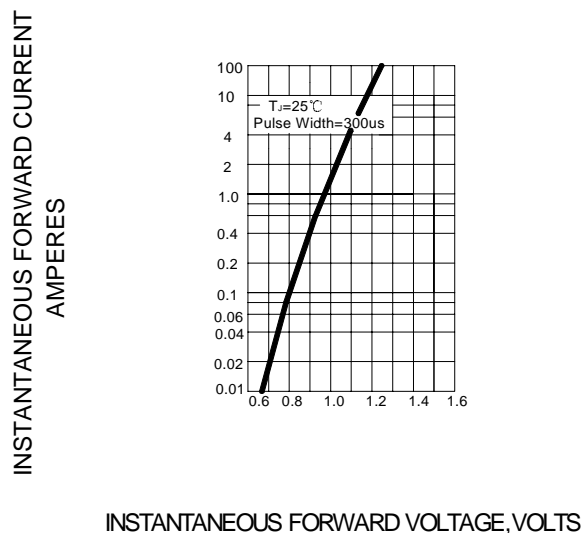

FIG.3 – PEAK FORWARD SURGE CURRENT

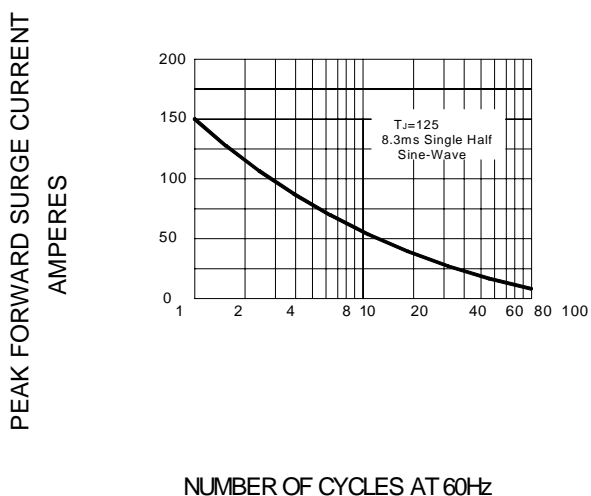

FIG.4 – TYPICAL JUNCTION CAPACITANCE

