

### KEY FEATURES

- LOW COST
- HIGH VOLTAGE – 200 VOLTS
- HIGH OUTPUT CURRENT – UP TO 30A
- 165 WATT DISSIPATION CAPABILITY
- 400 WATT OUTPUT CAPABILITY
- WIDE SUPPLY RANGE  $\pm 10V$  –  $\pm 100V$
- INTEGRATED HEAT SINK AND FAN
- TEMPERATURE REPORTING
- OVER-TEMPERATURE SHUTDOWN

### APPLICATIONS

- LINEAR MOTOR DRIVE
- INDUSTRIAL AUDIO
- SEMICONDUCTOR TESTING
- VIBRATION CANCELLATION
- MAGNETIC BEARINGS

### DESCRIPTION

The PAD119 high power operational amplifier is constructed with surface mount components to provide a cost effective solution for many industrial applications. With a footprint only 5.6 in<sup>2</sup> the PAD119 offers outstanding performance that rivals much more expensive hybrid component amplifiers or rack-mount amplifiers. User selectable external compensation tailors the amplifier's response to the application requirements. The PAD119 also features a substrate temperature reporting output and over-temp shutdown. The amplifier circuitry is built on a thermally conductive but electrically insulating substrate mounted to an integral heat sink and fan assembly. The resulting module is a small, high performance turn-key solution for many industrial applications.



PAD119 MOUNTED IN EVALUATION KIT

### A NEW CONCEPT

A critical task in any power amplifier application is cooling the amplifier. Until now component amplifier manufacturers often treated this task as an after-thought, left for the user to figure out. At **Power Amp Design** the best heat sink and fan combination is chosen at the start and becomes an integral part of the overall amplifier design. The result is the most compact and volumetric efficient design combination at the lowest cost. In addition, this integrated solution concept offers an achievable real-world power dissipation rating, not the ideal rating usually cited when the amplifier case is somehow kept at 25°C. The user no longer needs to specify, procure or assemble separate components.

## EQUIVALENT CIRCUIT

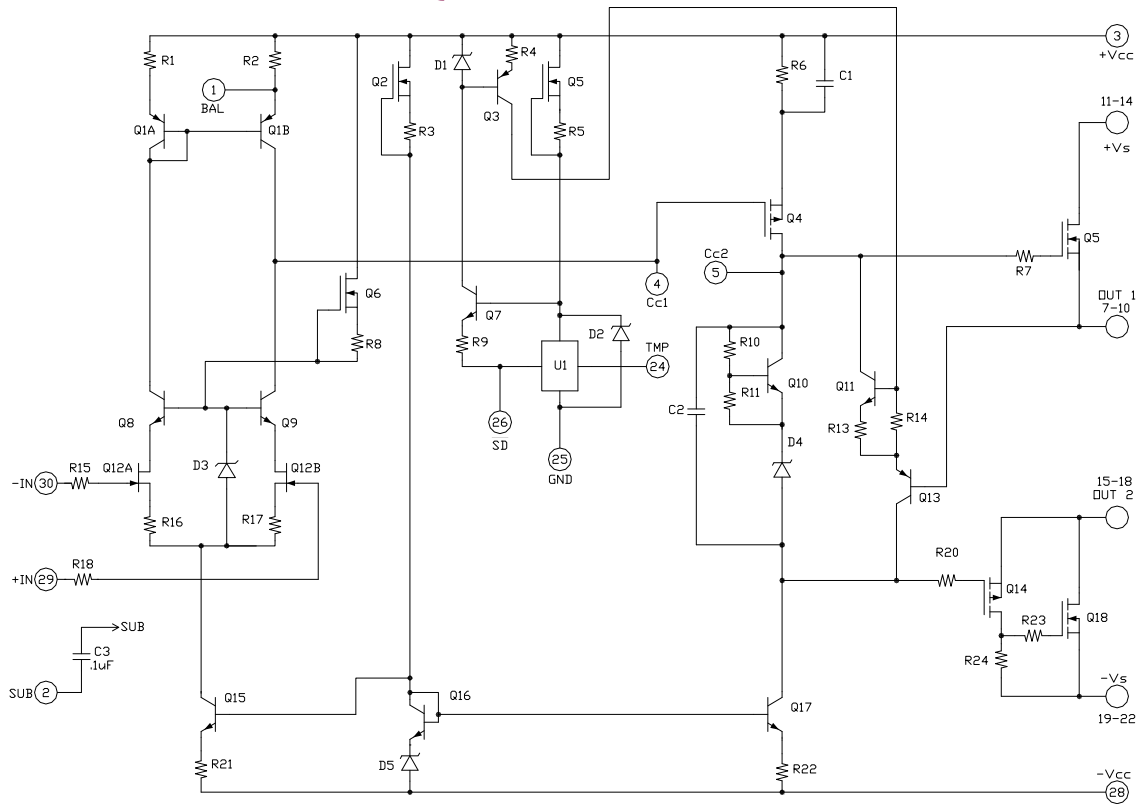

## AMPLIFIER PINOUT & CONNECTIONS

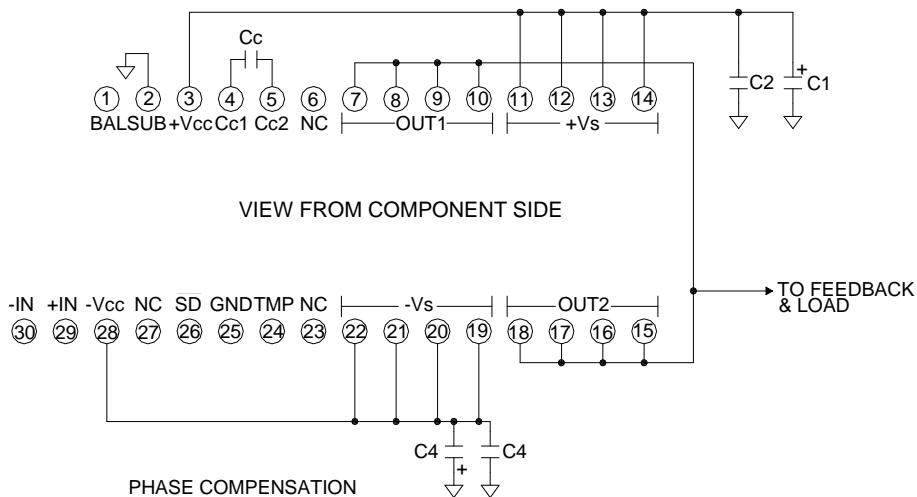

PHASE COMPENSATION		
GAIN	Cc	SLEW V/ $\mu$ S
1	470pF	3
$\geq 10$	100pF	8

\* SEE APPLICATION CIRCUITS FOR OTHER CONNECTIONS AND FUNCTIONS.

ABSOLUTE MAXIMUM RATINGS			
SUPPLY VOLTAGE, +V <sub>s</sub> to -V <sub>s</sub> <sup>7</sup>	200V	INPUT VOLTAGE	+V <sub>cc</sub> to -V <sub>cc</sub> <sup>7</sup>
SUPPLY VOLTAGE +V <sub>cc</sub> to -V <sub>cc</sub>	220V <sup>7</sup>	DIFFERENTIAL INPUT VOLTAGE	± 20V
OUTPUT CURRENT, peak	30A, within SOA	TEMPERATURE, pin solder, 10s	300°C
POWER DISSIPATION, internal, DC	165W	TEMPERATURE, junction <sup>2</sup>	150°C
TEMPERATURE RANGE, storage	-40 to 70°C <sup>5</sup>	OPERATING TEMPERATURE, heat sink	-40 to 105°C

PARAMETER	TEST CONDITIONS <sup>1</sup>	MIN	TYP	MAX	UNITS
<b>INPUT</b>					
OFFSET VOLTAGE			1	5	mV
OFFSET VOLTAGE vs. temperature	Full temperature range		20	50	μV/°C
OFFSET VOLTAGE vs. supply				20	μV/V
BIAS CURRENT, initial <sup>3</sup>				100	pA
BIAS CURRENT vs. supply				0.1	pA/V
OFFSET CURRENT, initial				50	pA
INPUT RESISTANCE, DC			100		G Ω
INPUT CAPACITANCE			4		pF
COMMON MODE VOLTAGE RANGE		± V <sub>cc</sub> ∓ 10			V
COMMON MODE REJECTION, DC		92			dB
NOISE	100kHz bandwidth, 1kΩ R <sub>s</sub>		10		μV RMS
<b>GAIN</b>					
OPEN LOOP	R <sub>L</sub> = 100Ω, C <sub>c</sub> =100pF	108			dB
GAIN BANDWIDTH PRODUCT @ 1MHz	C <sub>c</sub> =100pF		1		MHz
PHASE MARGIN	Full temperature range	60			degree
<b>OUTPUT</b>					
VOLTAGE SWING	I <sub>o</sub> = 20A	+V <sub>s</sub> -6.1			V
VOLTAGE SWING	I <sub>o</sub> = -20A	-V <sub>s</sub> +6.1			V
CURRENT, continuous, DC		20			A
CURRENT, peak within SOA				30	A
SLEW RATE, A <sub>v</sub> = -10	C <sub>c</sub> = 100pF	7	8.5		V/μS
SETTLING TIME, to 0.1%	2V Step		2		μS
RESISTANCE	No load, DC		3		Ω
<b>POWER SUPPLY</b>					
VOLTAGE <sup>7</sup>		± 15	± 75	± 100	V
CURRENT, quiescent			26	30	mA
<b>THERMAL</b>					
RESISTANCE, AC, junction to air <sup>4</sup>	Full temperature range, f ≥ 60Hz			.46	°C/W
RESISTANCE, DC, junction to air	Full temperature range			.76	°C/W
TEMPERATURE RANGE, heat sink		-40		105	°C
<b>FAN, 60mm dc brushless, ball bearing</b>					
OPERATING VOLTAGE			12		V
OPERATING CURRENT			150		mA
AIR FLOW			25		CFM
RPM			3800		RPM
NOISE			30		dB
L10, life expectancy, 50°C <sup>6</sup>			45		kHrs
L10, life expectancy, 25°C <sup>6</sup>			60		kHrs

### NOTES:

1. Unless otherwise noted: T<sub>c</sub>=25°C, compensation C<sub>c</sub>=470pF, DC input specifications are ± value given, power supply voltage is typical rating.
2. Derate internal power dissipation to achieve high MTBF.
3. Doubles for every 10°C of case temperature increase.
4. Rating applies if the output current alternates between both output transistors at a rate faster than 60Hz.
5. Limited by fan storage characteristics. During operation, even though the case may be at 85°C the fan will be at a lower temperature.
6. L10 refers to the time it takes for 10% of a population of fans to fail. MTBF (Mean Time Before Failure), on the other hand, refers to a 50% failure rate. The MTBF of fans used by Power Amp Design is 210 kHrs at 50C.
7. +V<sub>cc</sub> and -V<sub>cc</sub> must not be more than 20V greater than +V<sub>s</sub> and -V<sub>s</sub> respectively

### COOLING FAN

The PAD119 relies on its fan for proper cooling of the amplifier. Make sure that air flow to the fan and away from the heat sink remains unobstructed. The cooling method used is impingement cooling, which means that cool air is pushed into the heat sink and warm air is exhausted through the spaces between the heat sink fins.

### MOUNTING THE AMPLIFIER

The amplifier is supplied with four 4-40 M/F hex spacers at the four corner of the amplifier. Since the male threaded ends of the spacers extend beyond the amplifier pins the spacers provide a convenient alignment tool to guide the insertion of the amplifier pins into the circuit board. Once the amplifier is seated secure the module with the provided 4-40 nuts and torque to 4.7 in oz [3.8 N cm] max. See “**Dimensional Information**” for a detailed drawing.

### PHASE COMPENSATION

The PAD119 **must** be phase compensated to operate correctly. The compensation capacitor,  $C_C$ , is connected between pins 4 and 5. On page 6, Typical Performance Graphs, you will find plots for small signal response and phase response using compensation values of 100pF and 470pF. The compensation capacitor must be an NPO type capacitor rated for the full supply voltage (200V). On page 2, under Amplifier Pinout and Connections, you will find a table that gives recommended compensation capacitance value for various circuit gains and the resulting slew rate for each capacitor value. A compensation capacitor less than 100pF is not recommended.

### TEMPERATURE REPORTING

An analog output voltage is provided (pin 24, TMP) relative to ground and proportional to the temperature in degrees C. The slope is approximately  $-10.82\text{mV}/^\circ\text{C}$ . The output voltage follows the equation:

$$T = (2.127 - V) (92.42)$$

Where V is the TMP output voltage and T is the substrate temperature in degrees C.

This high impedance output circuit is susceptible to capacitive loading and pickup from the output of the amplifier. When monitoring TMP filter the voltage as shown in Figure 3. See **Applications Circuits**.

### THERMAL SHUTDOWN

The temperature monitoring circuit automatically turns off the output transistors when the substrate temperature reaches  $110^\circ\text{C}$ . When the substrate cools down  $10^\circ\text{C}$  the output is

enabled once again. The thermal shutdown feature is activated either by amplifier overloads or a failure of the fan circuit.

### EXTERNAL SHUTDOWN

When pin 26 ( $\overline{SD}$ ) is taken low (ground) the output stage is turned “off” and remains “off” as long as pin 26 is low. When pin 26 is monitored with a high impedance circuit it also functions as a flag, reporting when the amplifier is shut down. A “high” (+5V) on pin 26 indicates the temperature is in the normal range. A “low” (ground) indicates a shutdown condition. See **Application Circuits** for details on how to implement an external shutdown circuit and how to monitor the shutdown status.

### CURRENT LIMIT

The PAD119 does not have a current limiting circuit built in. However, a Current Limit Accessory Module, model PAD123, is available if the current limiting function is needed for the application. See the PAD123 data sheet and **Application Circuits** for a typical connection diagram.

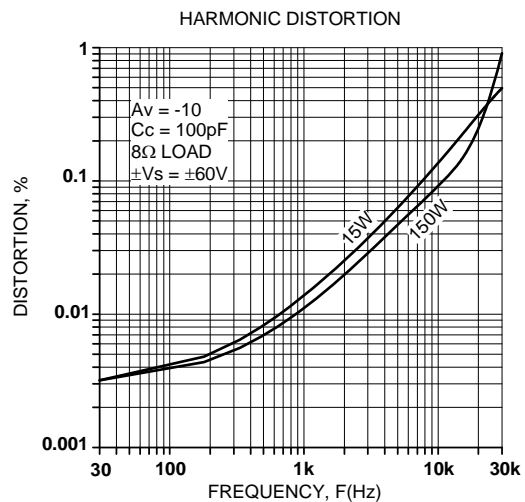
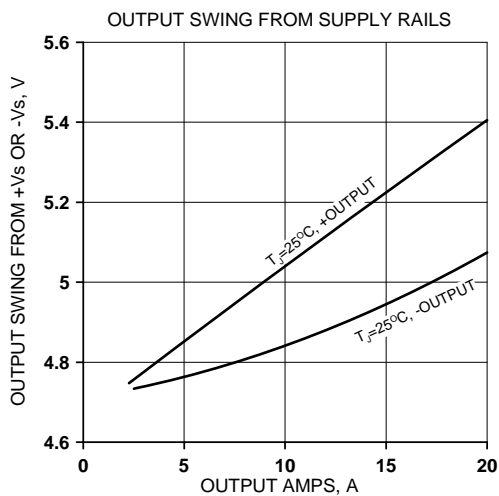
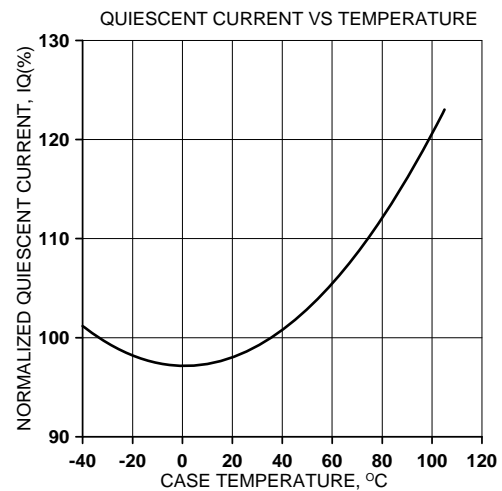
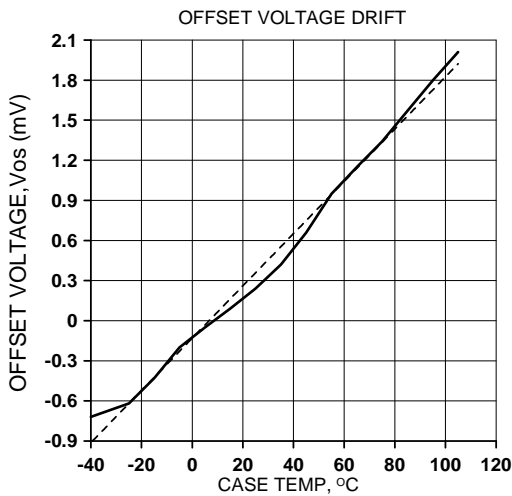
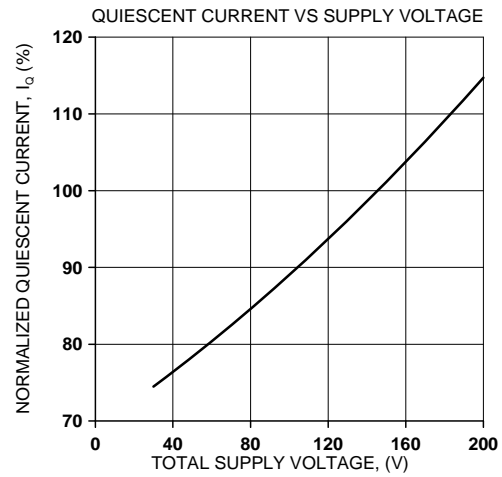
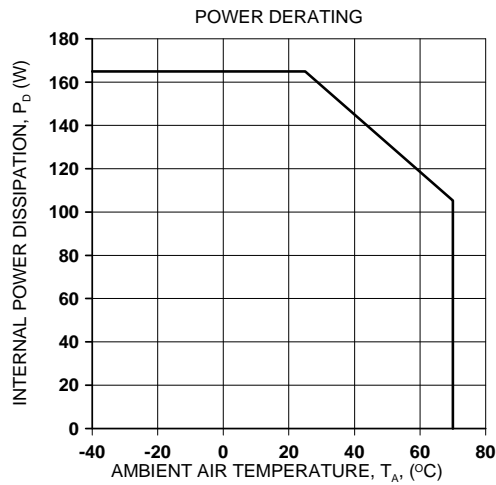

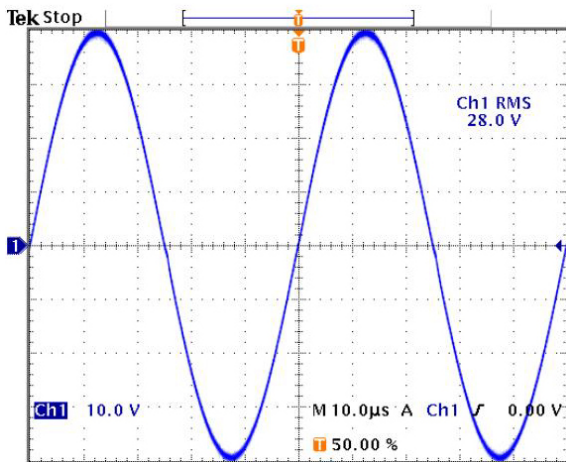
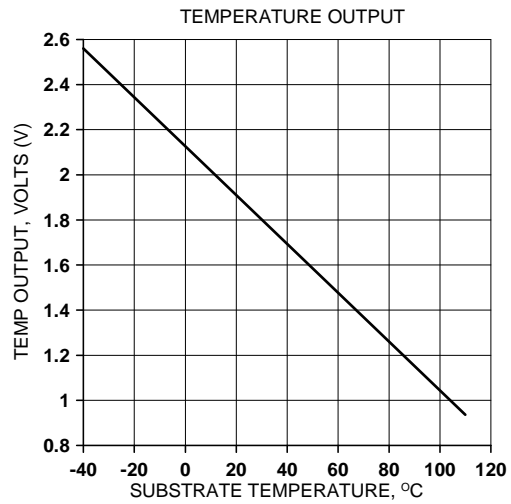
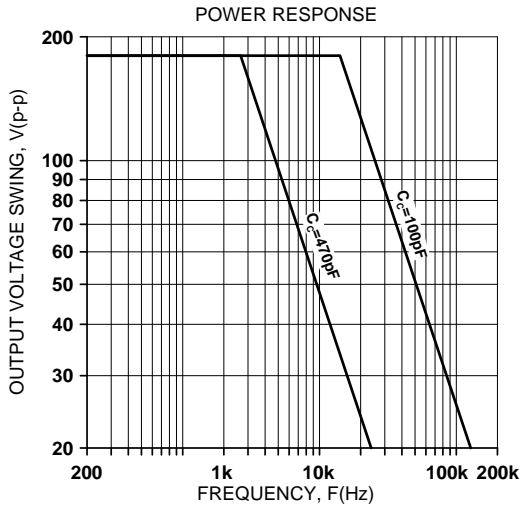
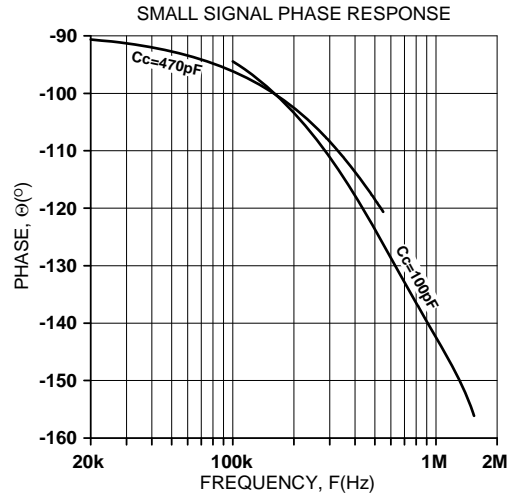
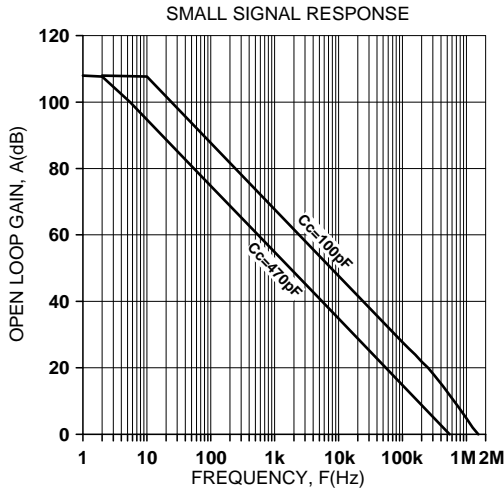

80V p-p 20kHz into 4 $\Omega$  load, G=-10, Cc=100pF

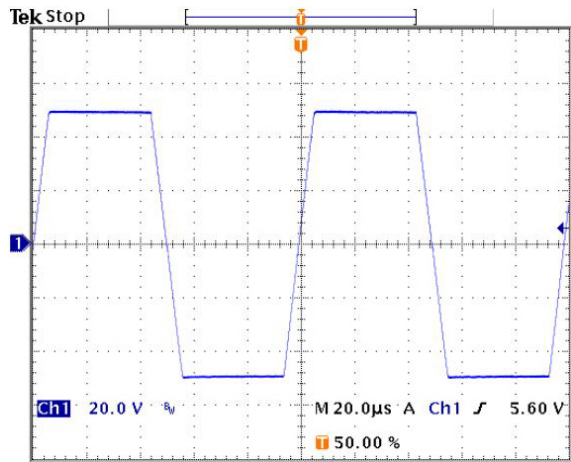

100Vp-p 10kHz Pulse into 8 $\Omega$  load, G=-10, Cc=100pF

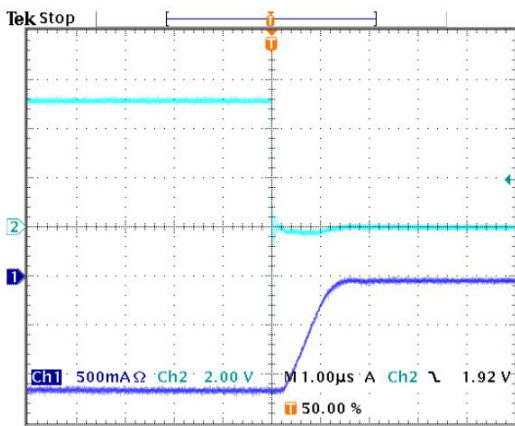

**SHUTDOWN RESPONSE, NEGATIVE OUTPUT TO ZERO TRANSITION**

The oscilloscope display at the left shows an expanded view of a 1kHz 1.2A p-p amplifier output signal being interrupted near the negative peak by a shutdown signal on Ch2. The Ch1 display shows the output *current* going to zero about 1.5µs after the shutdown signal goes low.

**SHUTDOWN RESPONSE, POSITIVE OUTPUT TO ZERO TRANSITION**

The oscilloscope display at the right shows an expanded view of a 1kHz 1.2A p-p amplifier output signal being interrupted near the positive peak by a shutdown signal on Ch2. The Ch1 display shows the output *current* going to zero about 2.5µs after the shutdown signal goes low.

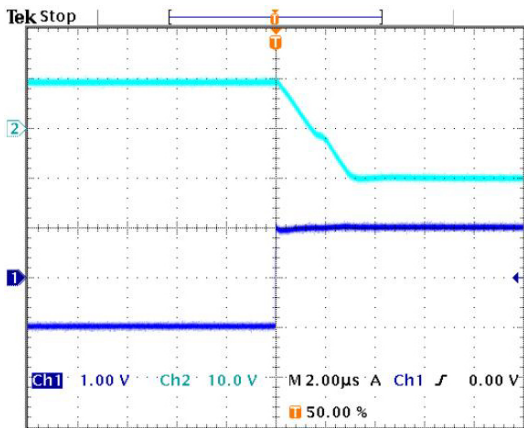
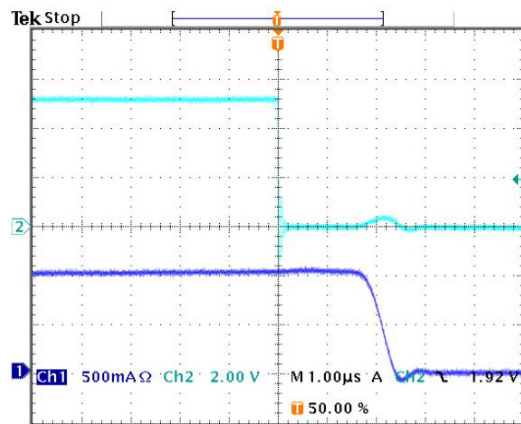

Pulse Response, Positive to Negative, 4Ω Load  
G=-10, Cc=100pF

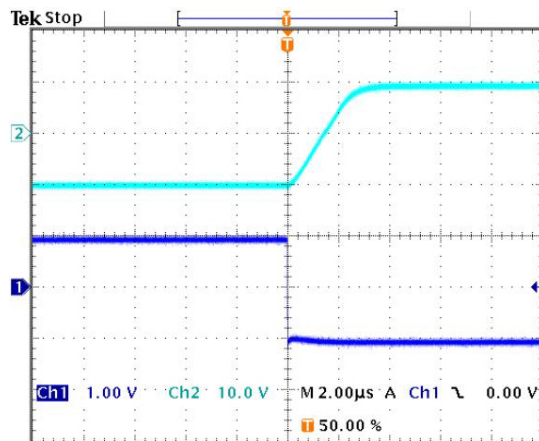

Pulse Response, Negative to Positive, 4Ω Load  
G=-10, Cc=100pF

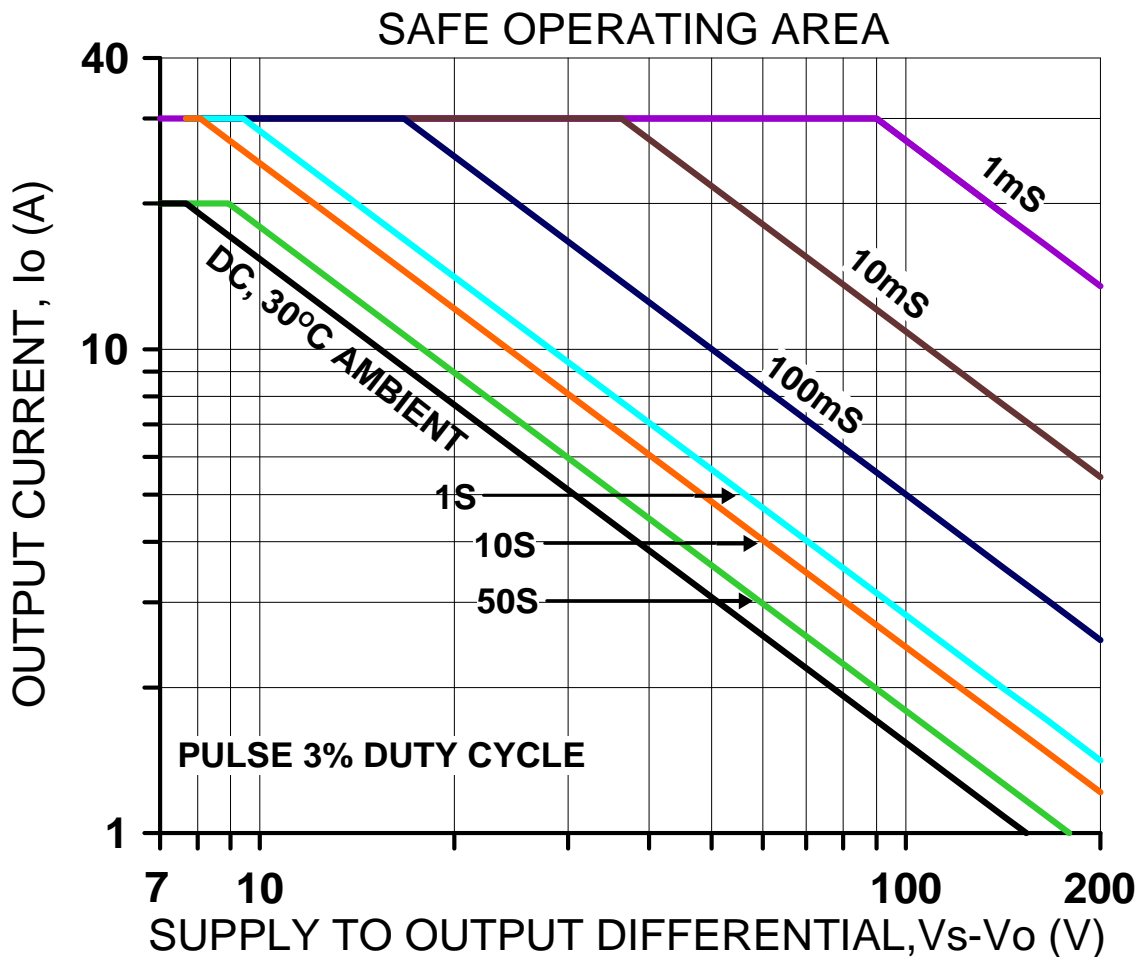

SAFE OPERATING AREA

The safe operating area (SOA) of a power amplifier is its single most important specification. The SOA graph presented above serves as a first approximation to help you decide if the PAD119 will meet the demands of your application. But a more accurate determination can be reached by making use of the **PAD Power**™ spreadsheet which can be found in the *Thaler* website. While the graph above adequately shows DC SOA and some pulse information it does not take into account ambient temperatures higher than 30°C, AC sine, phase or non-symmetric conditions that often appear in real-world applications. The **PAD Power**™ spreadsheet takes all of these effects into account.



# HIGH POWER OPERATIONAL AMPLIFIER

# PAD119

## DIMENSIONAL INFORMATION

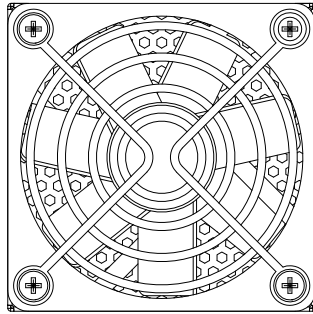

NOTES:

1. PINS .0025" SQUARE X30
2. RECOMMENDED HOLE FOR MOUNTING 0.129" X4
3. RECOMMENDED HOLE FOR PINS 0.052" D.
4. TOTAL ASSEMBLY WEIGHT APPROX 8.1 oz [230 g]
5. HEAT SINK WEIGHT APPROX 4.55 oz [129 g]

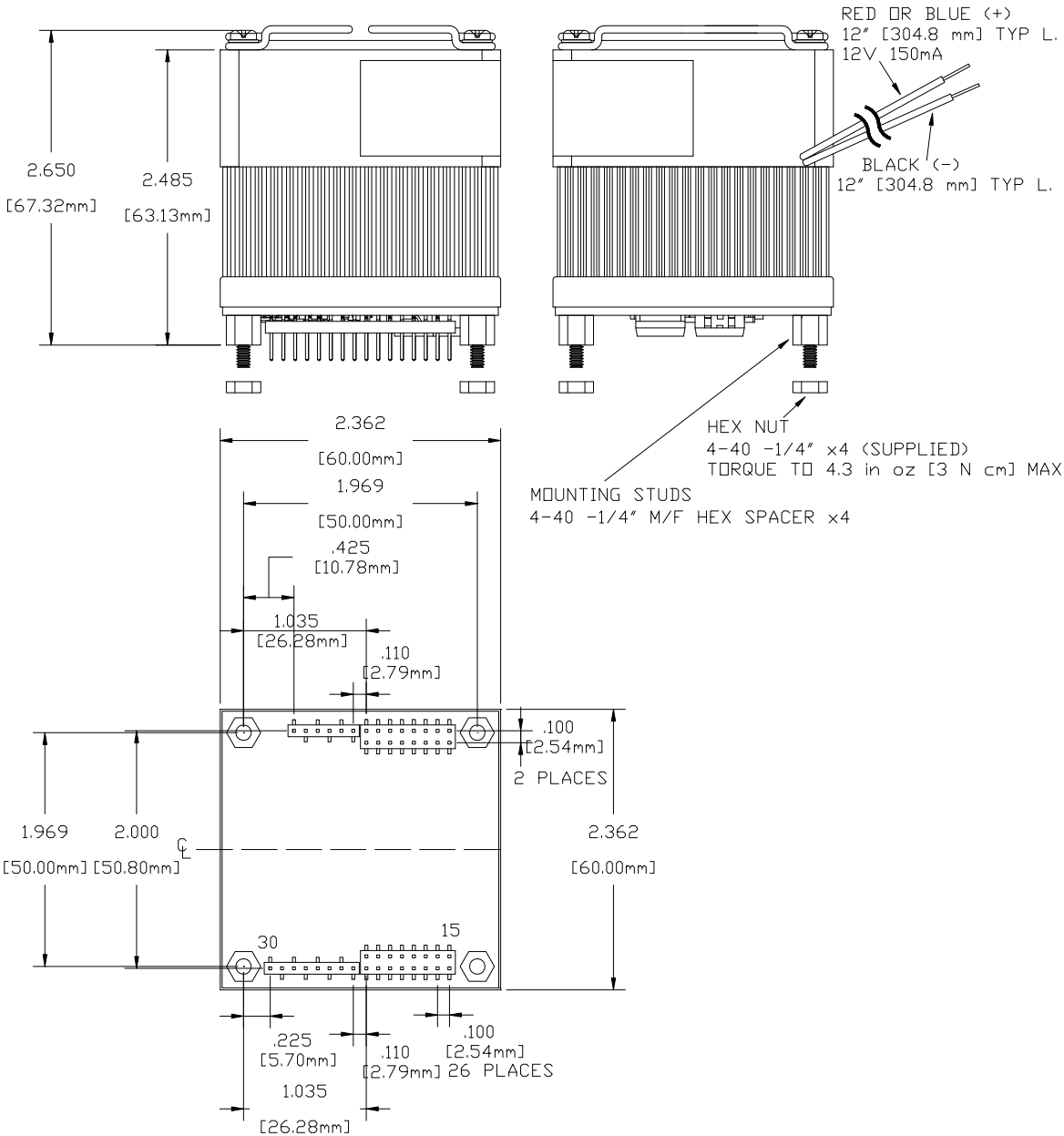

**Thaler** Corporation  
 • PAD119 • HIGH POWER OPERATIONAL AMPLIFIER

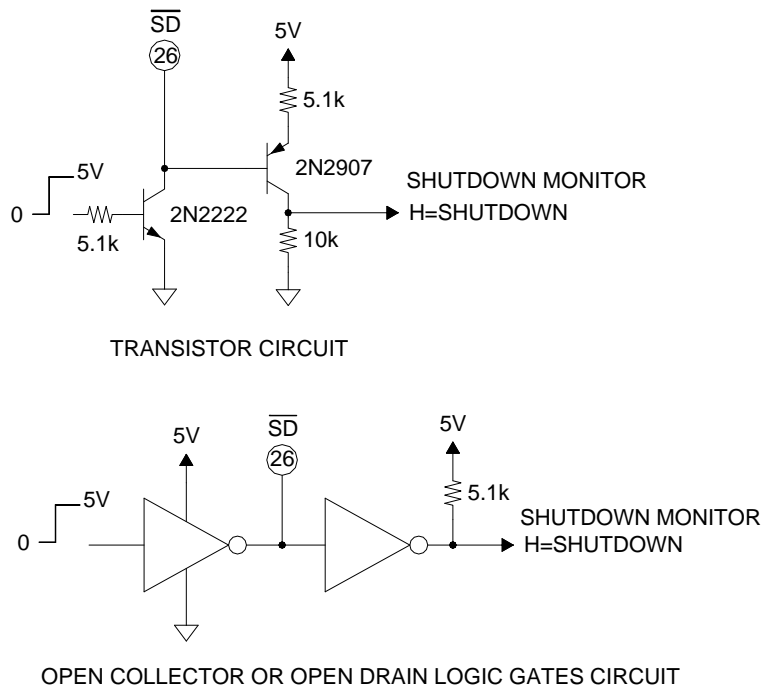

FIGURE 1.  
EXTERNAL SHUTDOWN WITH MONITOR

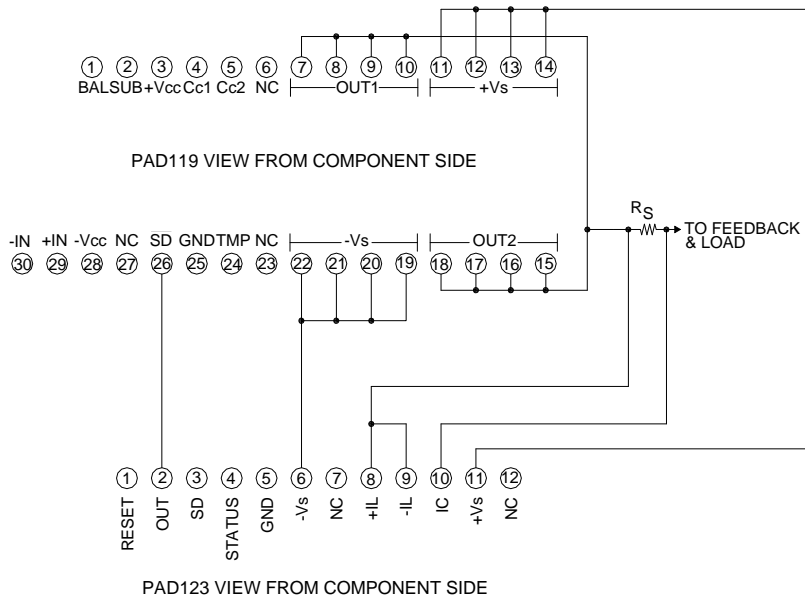

FIGURE 2.  
TYPICAL PAD119 CONNECTIONS TO PAD123 ACCESSORY MODULE

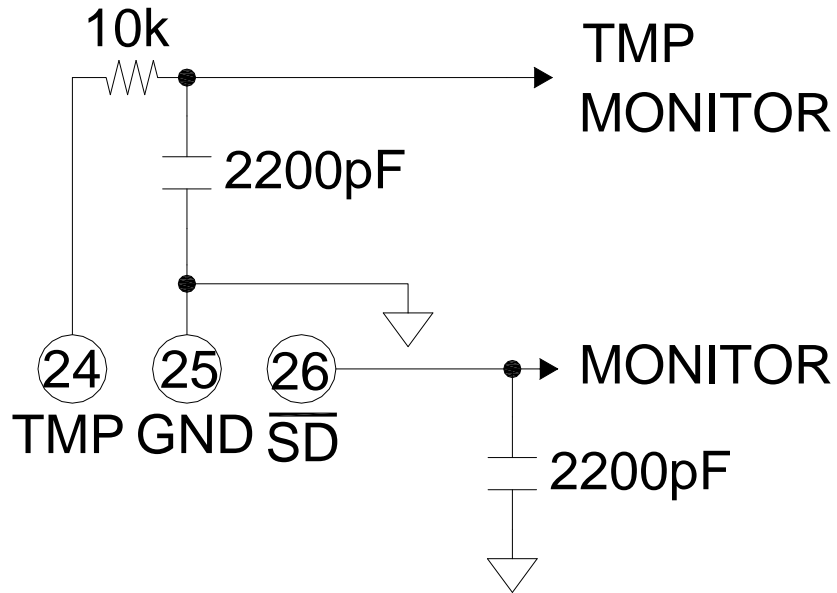

FIGURE 3.  
MONITORING TMP AND  $\overline{SD}$  OUTPUTS