

## Description

The single output DGP30 Series is designed to accept an extended 2:1 input voltage range for use in industrial and telecom applications. The output of the converter is electrically isolated, thereby allowing the output to be configured as a positive or negative output voltage. For additional system utility, output Trim and Remote On/Off are featured. Overcurrent protection, overtemperature protection, and output overvoltage transient protection allow safe, reliable operation.

## Features

- RoHS lead solder exemption compliant
- Remote On/Off and trim
- Low Off current
- Overcurrent and overtemperature protection
- Efficiencies to 86%
- Transient output overvoltage protection
- 1544 V isolation
- Five-sided, shielded case
- Extended range input (2:1)



Selection Chart				
Model	Input Range VDC		Output VDC	Output mA
	Min	Max		
DGP30E48S5	36	72	5	5000
DGP30E48S12	36	72	12	2500
DGP30E48S15	36	72	15	2000

Model numbers highlighted in yellow or shaded are not recommended for new designs.

General Specifications (1)				
All Models				Units
<b>ON/OFF Function (2)</b>				
ON Logic Level or Pin Open	MIN	8.0	VDC	
OFF Logic Level	MAX	2.0	VDC	
Input Resistance	TYP	100	Kohms	
Converter Idle Current ON/OFF Pin Low	TYP	<1	mA	
<b>Isolation (3)</b>				
Isolation Voltage 10µA Leakage Input-Output	MIN	1544	VDC	
Input to Output Capacitance	TYP	300	pF	
<b>Output Trim Function (4)</b>				
Input Resistance	TYP	20	Kohms	
Programming Range	MIN	±5	%	
<b>Environmental</b>				
Case Operating Range, Tc No Derating	MIN MAX	-40 +90	°C	
Storage Range	MIN MAX	-55 105	°C	
Thermal Impedance (5)	TYP	10	°C/Watt	
Thermal Shutdown Case Temperature	TYP	100	°C	
<b>General</b>				
MTBF (Calculated)	TYP	800,000	HRS	
Unit Weight	TYP	1.9 / 54	oz / gm	
Chassis Mounting Kit	CM2A1			

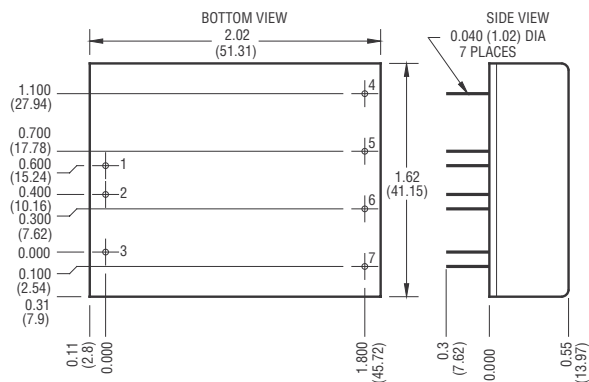

Mechanical tolerances unless otherwise noted:

X.XX dimensions: ±0.020 inches

X.XXX dimensions: ±0.005 inches

Pin	Function
1	+INPUT
2	-INPUT
3	ON/OFF
4	NO PIN
5	+OUT
6	-OUT
7	TRIM

## NOTES

- (1) All parameters measured at Tc = 25 °C, nominal input voltage and full rated load unless otherwise noted.
- (2) ON/OFF pin is referenced to pin 2, -Input. See DGP30 Series Application Notes for the specific requirements of this feature.
- (3) The Case is electrically connected to Pin 1, +Input.
- (4) Full output trim range may not be available at minimum input voltage and full load. Full trim is guaranteed from minimum input voltage, plus 5%, and full load.
- (5) The case thermal impedance is specified as the case temperature rise over ambient per package watt dissipated.

Input Parameters (1)					
Model		DGP30E48S5	DGP30E48S12	DGP30E48S15	Units
Voltage Range	MIN	36.0			VDC
	TYP	48.0			
	MAX	72.0			
Input Current	Full Load	630	730	730	mA
	No Load	4	4	4	
Efficiency	TYP	84	86	86	%
Switching Frequency	TYP	200			kHz
Maximum Input Overvoltage, 100ms No Damage	MAX	85			VDC
Turn-on Time	TYP	15			ms

Output Parameters (1)					
Model		DGP30E48S5	DGP30E48S12	DGP30E48S15	Units
Output Voltage		5	12	15	VDC
Rated Load (2)	MIN	1250	625	500	mA
	MAX	5000	2500	2000	
Voltage Range 100% Load	MIN	4.95	11.90	14.90	VDC
	TYP	5.00	12.00	15.00	
	MAX	5.05	12.10	15.10	
Load Regulation Min-Max Full Load	TYP	0.5	0.2	0.2	%
	MAX	1.0	1.0	1.0	
Line Regulation Vin = Min-Max VDC	TYP	0.2			%
	MAX	1.0			
Short Term Stability (3)	TYP	<0.02			%
Long Term Stability	TYP	<0.05			%/kHrs
Input Ripple Rejection (4)	TYP	60			dB
Noise, 0-20MHz bw (5)	TYP	75	100	100	mV <sub>PP</sub>
Temperature Coefficient	TYP	50			ppm/°C
	MAX	150			
Overvoltage Clamp	TYP	6.8	15	18	VDC
Short Circuit Protection to Common for all Outputs		Continuous Current Limiting and Overtemperature Shutdown			

## NOTES

- (1) All parameters measured at Tc=25 °C case temperature, nominal input voltage and full rated load unless otherwise noted.
- (2) Minimum load required for rated regulation only. Module will not be damaged if run at less than minimum load.
- (3) Short term stability is specified after a 30 minute warm-up at full load, and with constant line, load and ambient conditions.
- (4) The input ripple rejection is specified for DC to 120 Hz ripple with a modulation amplitude of 1% Vin.
- (5) Noise is measured per Technical Reference Section. Output noise is measured with a 1 μF tantalum capacitor connected 1" from the output pins.

**DGP30 SERIES APPLICATION NOTES:**

**External Capacitance Requirements**

No external capacitance is required for operation of the DGP30 Series. However, it is recommended that the DGP30 Series use a capacitor of sufficient ripple current capacity connected across the input pins if a capacitive input source is farther than 1" from the converter. To meet the reflected ripple requirements of the converter, an input impedance of less than 0.05 Ohms from DC to 200 kHz is required. External output capacitance is not required for operation, however it is recommended that 1  $\mu$ F to 10  $\mu$ F of tantalum and 0.001 to 0.1  $\mu$ F ceramic capacitance be selected for reduced system noise. Additional output capacitance may be added for increased filtering, but should not exceed 400  $\mu$ F.

**Negative Outputs**

A negative output voltage may be obtained by connecting the +OUT to circuit ground and connecting -OUT as the negative output.

**Remote ON/OFF Operation**

The remote ON/OFF pin may be left floating if this function is not used. It is recommended to drive this pin with an open collector arrangement or a relay contact. When the ON/OFF pin is pulled low with respect to the -INPUT, the converter is placed in a low power drain state. Since the ON/OFF pin is driven by a 9 volt internal source via a 100 kOhm resistor, the pin should not be driven by TTL logic. Attempts to drive this circuit with logic circuits may result in damage to user circuitry.

**Output TRIM**

The TRIM pin may be used to adjust the output  $\pm 5\%$  from the nominal setting. This function allows adjustment for voltage drops in the system wiring, as well 5.2 volt outputs for ECL applications. Figure 1 shows the proper connections to use this function. A trimpot value of 10 kOhm should be used for the 5 volt output. A trimpot value of 20 kOhm should be used for 12 and 15 volt outputs. If the TRIM function is not required, the pin may be left floating.

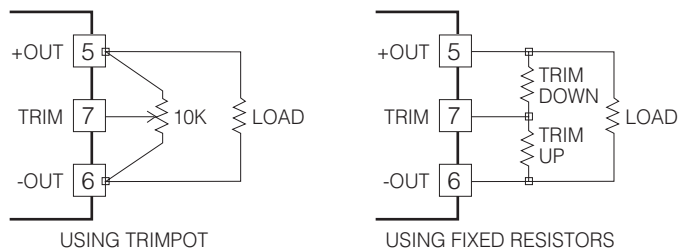
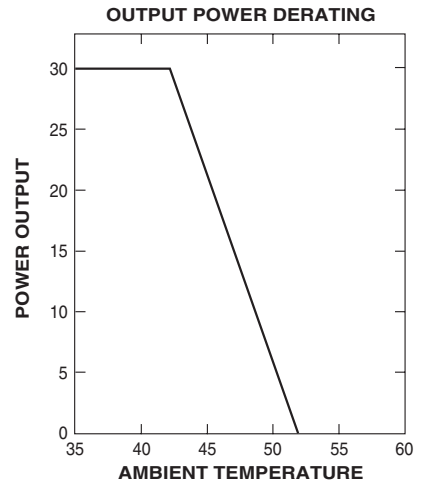
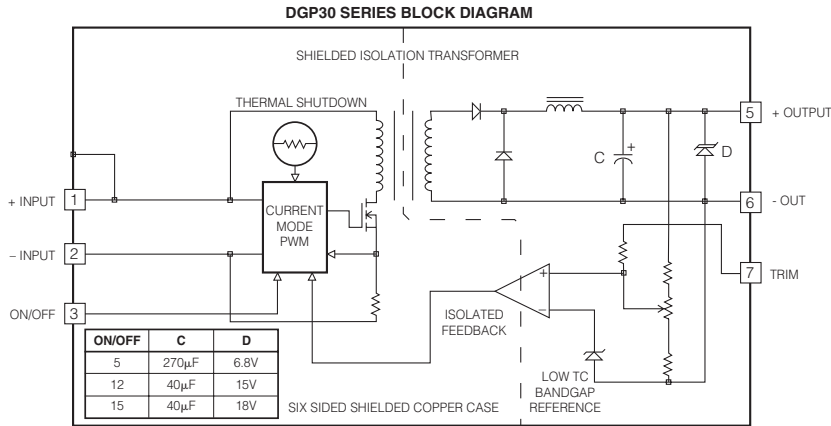
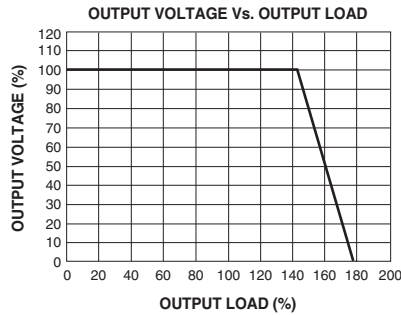
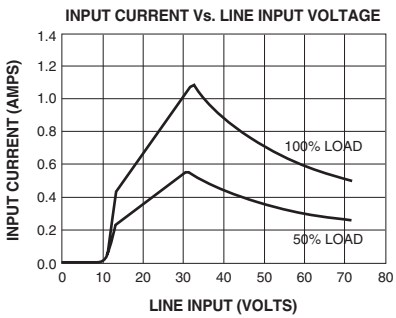
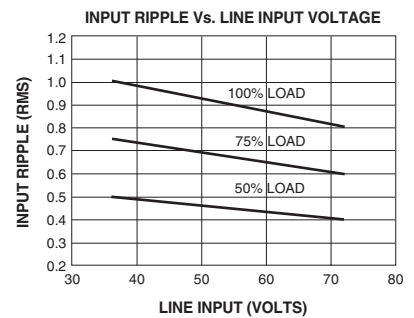
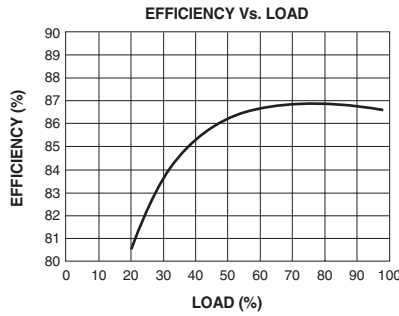
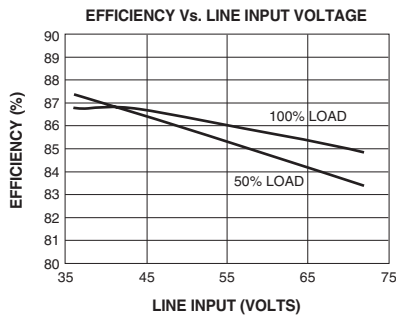

Figure 1.



Typical Performance: ( $T_c=25^\circ\text{C}$ ,  $V_{in}=\text{Nom VDC}$ , Rated Load)



**NUCLEAR AND MEDICAL APPLICATIONS** - Power-One products are not designed, intended for use in, or authorized for use as critical components in life support systems, equipment used in hazardous environments, or nuclear control systems without the express written consent of the respective divisional president of Power-One, Inc.

**TECHNICAL REVISIONS** - The appearance of products, including safety agency certifications pictured on labels, may change depending on the date manufactured. Specifications are subject to change without notice.