

#### FEATURES

- Plastic package has Underwriters Laboratory flammability Classification 94V-0.
- Glass passivated chip junction.
- High surge overload rating : 35A peak.
- Saves space on printed circuit boards.
- Recommended for non-automotive applications.

#### MAXIMUM RATING (Ta=25 °C)

CHARACTERISTIC	SYMBOL	RATING	UNIT
repetitive peak reverse voltage	$V_{RRM}$	600	V
RMS voltage	$V_{RMS}$	420	V
DC blocking voltage	$V_{DC}$	600	V
Average forward output rectified current (see Fig.1) On glass-epoxy P.C.B on aluminum substrate.	$I_{F(AV)}$	0.5 (Note1) 0.8 (Note2)	A
Peak forward surge current	$I_{FSM}$	35.0	A
Rating for fusing (t<8.3ms)	$I^2t$	5.0	A <sup>2</sup> sec
Operating Junction and Storage Temperature Range	$T_j, T_{stg}$	-55~150	°C

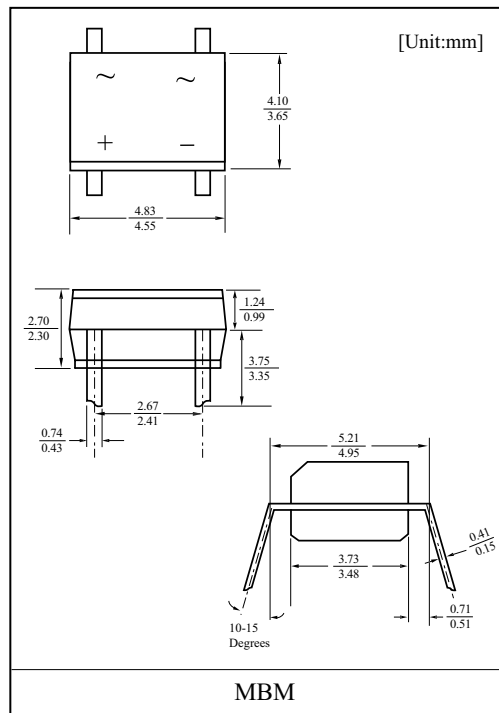

#### Marking

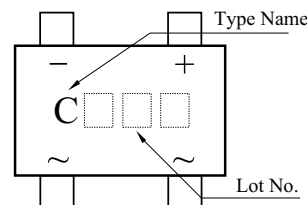

#### ELECTRICAL CHARACTERISTICS (Ta=25 °C)

CHARACTERISTIC	SYMBOL	CONDITION	MIN	TYP	MAX	UNIT
Forward voltage	$V_F$	$I_F=0.4A$	-	-	1.0	V
Leakage current	$I_R$	$V_R=600V$	-	-	5.0	$\mu A$
			-	-	100	
Junction capacitance	$C_j$	$V_R=4.0V, f=1.0MHz$	-	13	-	pF
Typical thermal resistance	$R_{th(A)}$ (Note 1)	Junction to ambient	-	-	85	$^{\circ}C/W$
	$R_{th(A)}$ (Note 2)		-	-	70	
	$R_{th(L)}$ (Note 1)	Junction to lead	-	-	20	

Note 1) on glass epoxy P.C.B mounted on 0.05 × 0.05" (1.3 × 1.3mm) Pads.

Note 2) on aluminum substrate P.C.B with an area of 0.8 × 0.8" (20 × 20mm) mounted on 0.05 × 0.05" (1.3 × 1.3mm) solder pad.

Fig.1 Derating Curve for Output Rectified Current

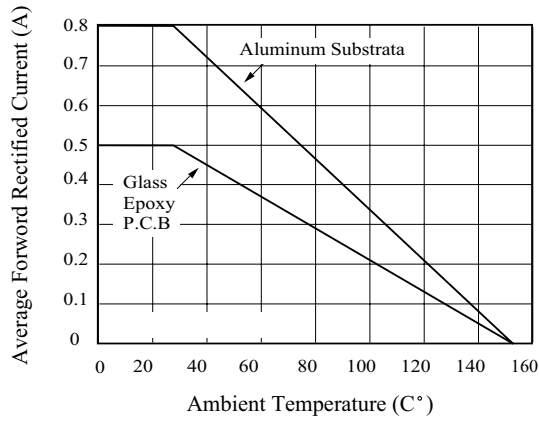

Fig.2 Maximum Non-Repetitive Peak Forward Surge Current Per Leg

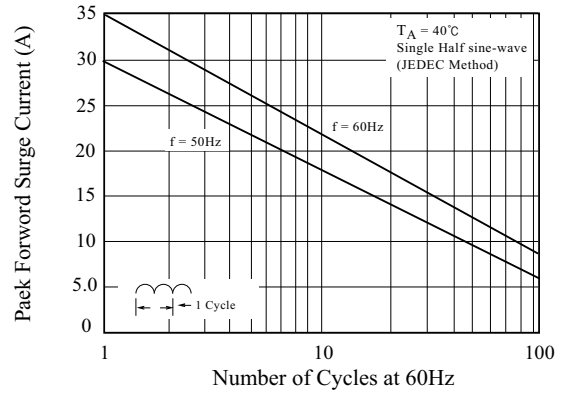

Fig.3 Typical Forward Characteristics Per Leg

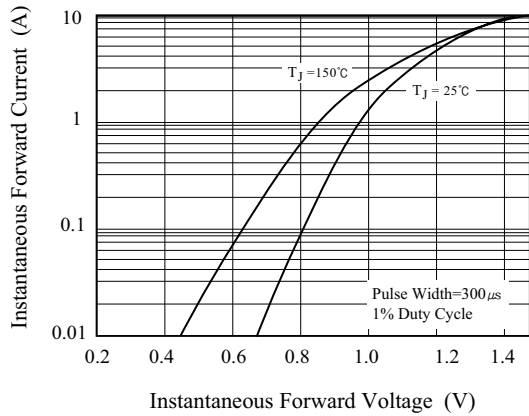

Fig.4 Typical Reverse Leakage Characteristics Per Leg

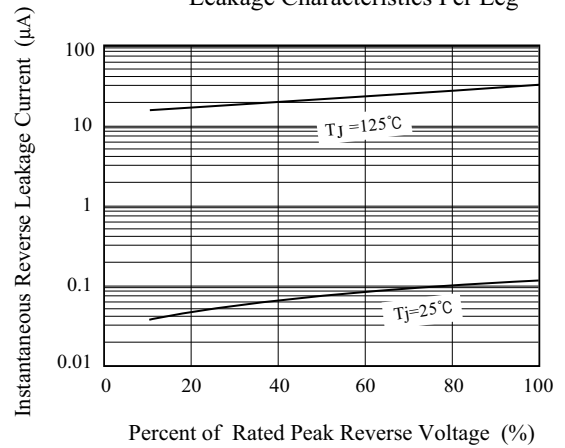

Fig.5 Typical Junction Capacitance Per Leg

