

LINEAR IC

FREQUENCY-TO-VOLTAGE
CONVERTER

MB4206

FREQUENCY-TO-VOLTAGE CONVERTER
WITH SINGLE POWER SUPPLY COMPARATOR

The Fujitsu MB4206 is a frequency-to-voltage converter with an on-chip comparator. The MB4206 uses a charge pump driven by a positive-edge Schmitt trigger/flip-flop input so stable operation is achieved against noise signal input. The output of the comparator is zener-clamped to a reference voltage; thus, a precise hysteresis output is obtained. The overall design makes the circuit fairly tolerant of imperfections in the input waveform.

- Conversion coefficient determined by RC pair:

$$V_{O(F)} = F_{IN} \cdot R_T \cdot C_T \cdot V_R$$
- Positive edge-triggered frequency input
- Equal internal reference high-level output and comparator high level output
- Package
 - 8-pin plastic SIP package (Suffix: -PS)

■ ABSOLUTE MAXIMUM RATINGS (see NOTE)

(Ta= 25°C)

Rating	Symbol	Value	Unit
Power Supply Voltage	VCC	24	V
Surge Voltage at VCC	VCC(S)	40 (t ≤ 50ms)	V
Zener Current	I _Z	20	mA
Power Dissipation	P _D	300 (Ta ≤ 85°C)	mW
Operating Temperature	T _{OP}	-30 to +85	°C
Storage Temperature	T _{STG}	-55 to +125	°C

NOTE: Permanent device damage may occur if the above **Absolute Maximum Ratings** are exceeded. Functional operation should be restricted to the conditions as detailed in the operational sections of this data sheet. Exposure to absolute maximum rating conditions for extended periods may affect device reliability.

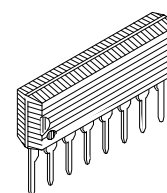

PLASTIC PACKAGE
(SIP-08P-M03)

PIN ASSIGNMENTS

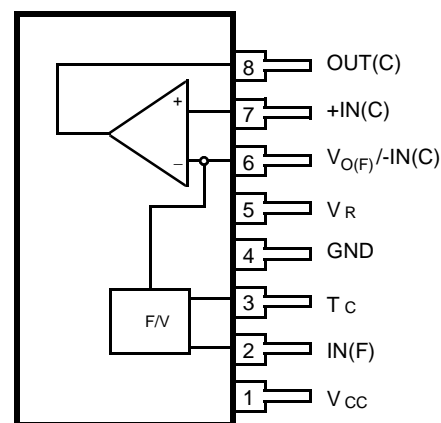

(Front View)

Fig. 1 — MB4206 BLOCK DIAGRAM

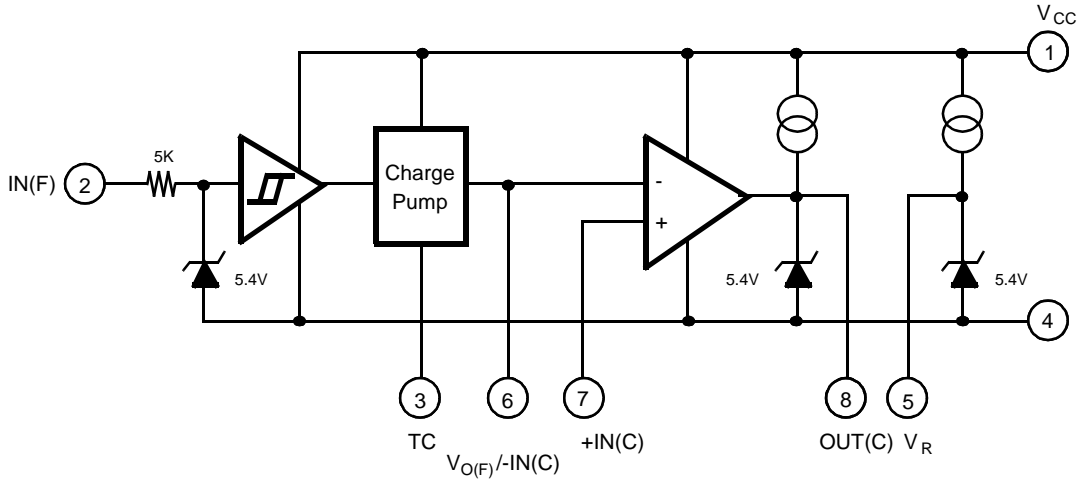
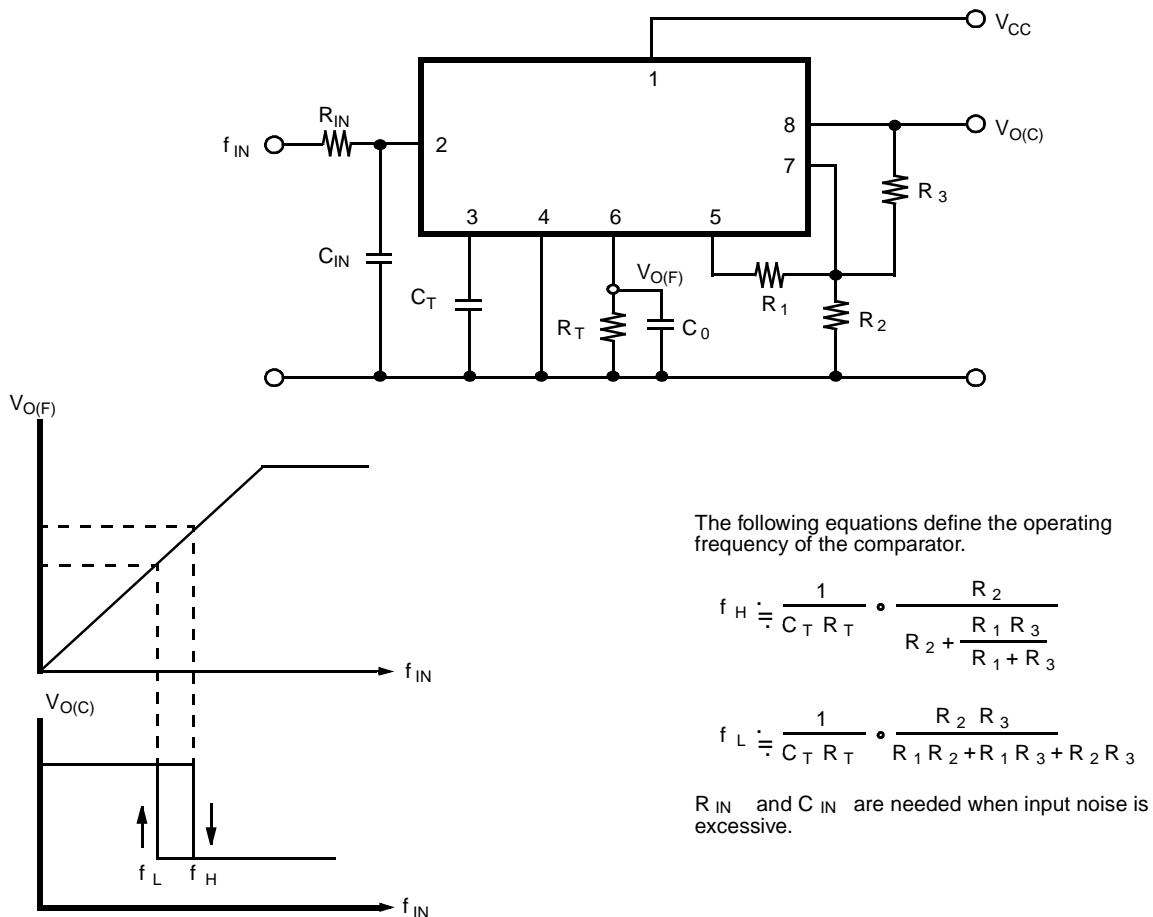

FIG. 2 — TYPICAL HOOKUP AND OPERATING PARAMETERS



■ ELECTRICAL CHARACTERISTICS

(Ta = 25°C, Vcc = 12V)

Parameter	Symbol	Condition	Value			Unit	
			Min	Typ	Max		
Power Supplies	Power Supply Current	I _{CC}	-	7.0	10.0	mA	
	Power Supply Voltage	V _{CC}	6.5	-	24	V	
	Reference Voltage	V _R	I _{L(R)} =1mA	5.0	5.4	5.8	V
	Reference Voltage Temperature Coefficient		I _{L(R)} =1mA	-	+1.4	-	mV/°C
F/V Converter	Input High Voltage	V _{IH}	2.4	-	24	V	
	Input Low Voltage	V _{IL}	0	-	1.2	V	
	Positive-edge		1	-	-	V/ms	
	Negative-edge		0.1	-	-	V/ms	
	Input Current	I _I	V _{IH(F)} =24V	-	4	8	mA
			V _{IL(F)} =1.2V	-	-	0.1	mA
	Output Current	I _O	V _{T(C)} =2.5V	0.26	0.4	0.58	mA
	F/V Coefficient ^{*1}	K	C _T =0.1μF, R _T =47kΩ, f=100Hz	0.9	1.0	1.1	-
Linearity ^{*2}		C _T =0.1μF, R _T =47kΩ	-	±0.3	-	%	
Comparator	Input Offset Voltage	V _{IO}	-	2.0	10	mV	
	Input Bias Current ^{*3}	I _I	-	0.5	3.0	μA	
	Common Mode Input Voltage ^{*4}	V _{ICM}		0	-	V _R	V
	Voltage Gain	A _V	R _L =10kΩ	-	100	-	dB
	Output Voltage	V _{OL}	I _{SINK} =3mA	-	0.1	0.2	V
		V _{OH}	I _L =0.5mA	5.0	5.4	5.8	V
	Sink Current	I _{SINK}	V _{OL} ≤ 1V	8	22	-	mA

Note: *1 $V_{O(F)} = K \cdot V_R \cdot C_T \cdot R_T \cdot f$

*2 With $f_{IN} = 100\text{Hz}$ as a reference, linearity is defined as the straight-line deviation over an input frequency range of 50- to - 150 Hz — see TYPICAL PERFORMANCE CHARACTERISTICS.

*3 The current flows from IC.

*4 If V_{CC} is lower than V_R, use (V_{CC}-2).

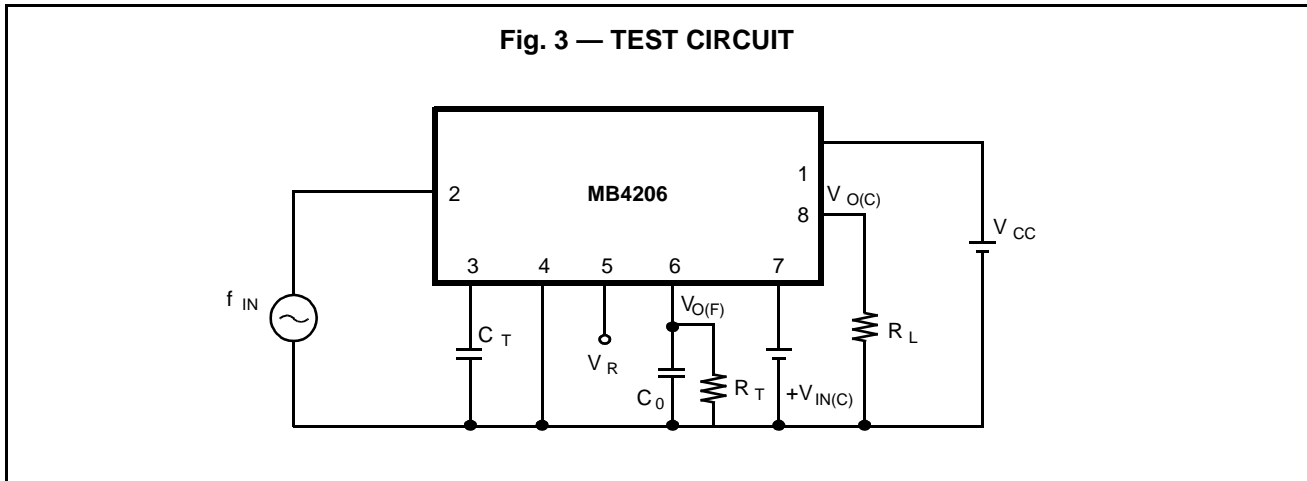

■ TYPICAL PERFORMANCE CHARACTERISTICS

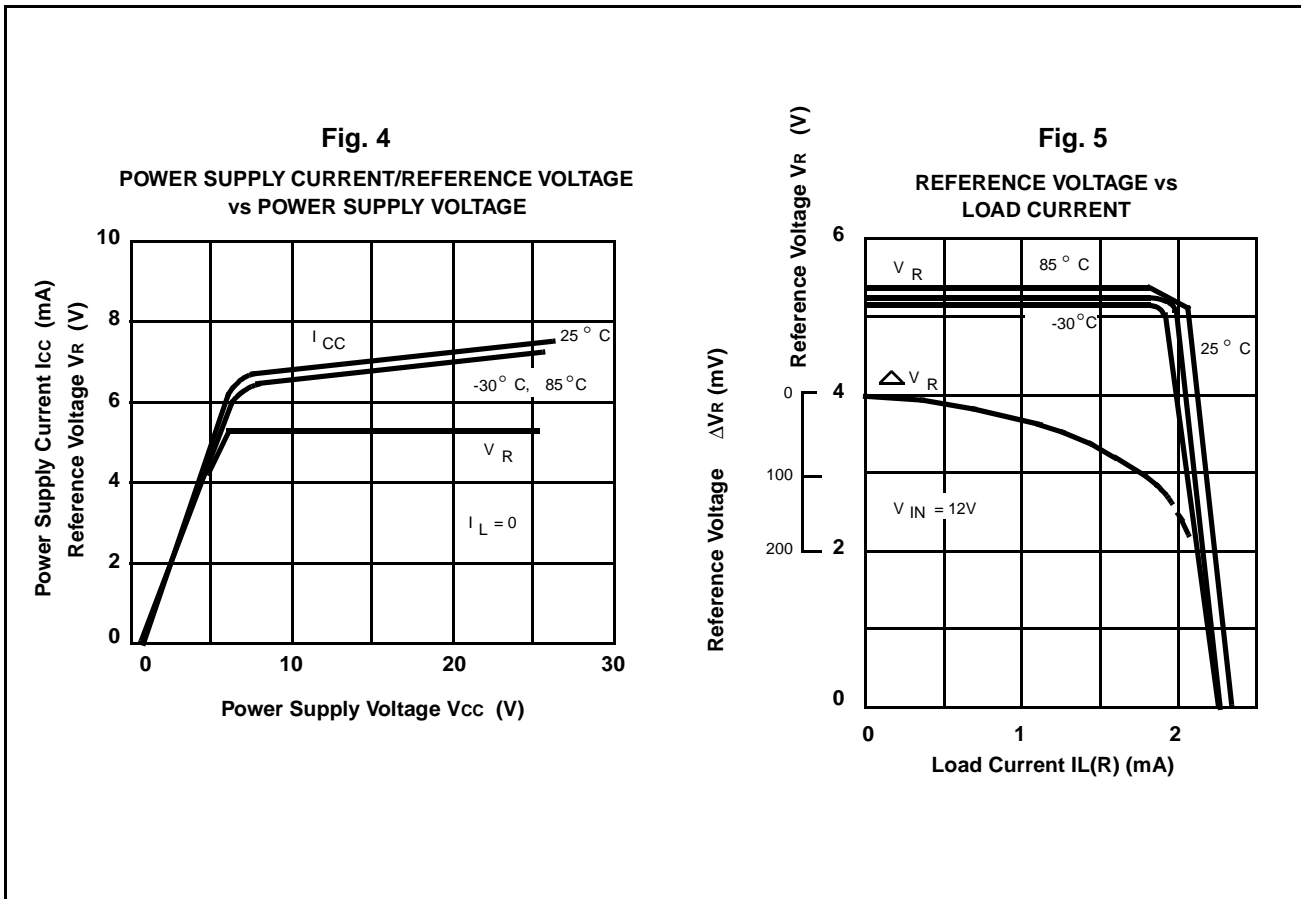

■ TYPICAL PERFORMANCE CHARACTERISTICS (Continued)

Fig. 6

OUTPUT CURRENT vs OPERATING TEMPERATURE

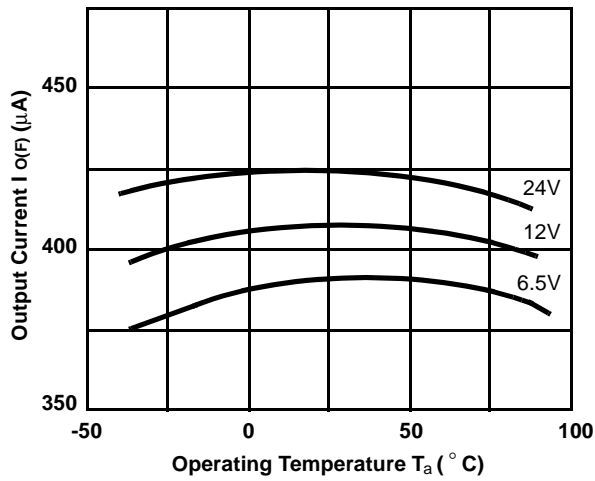

Fig. 7

OUTPUT LOW VOLTAGE vs SINK CURRENT

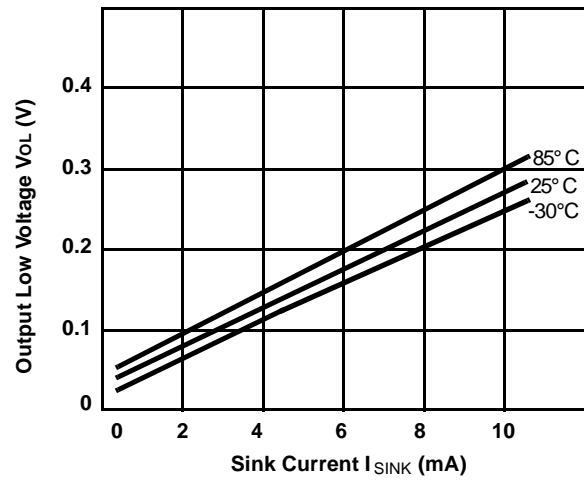

Fig. 8

F/V CONVERTER OUTPUT VOLTAGE vs INPUT FREQUENCY

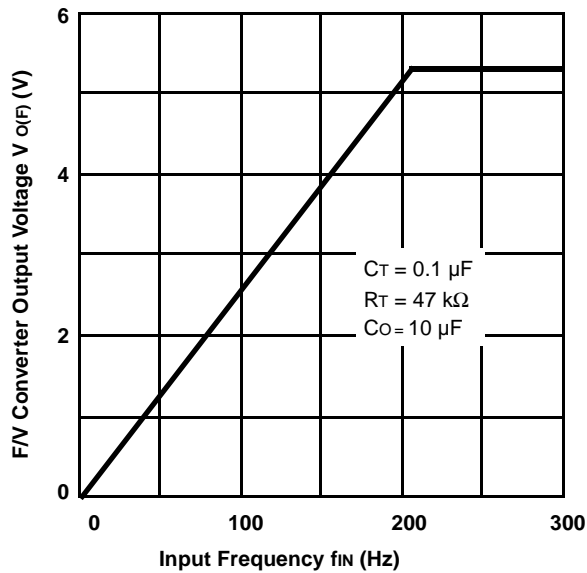
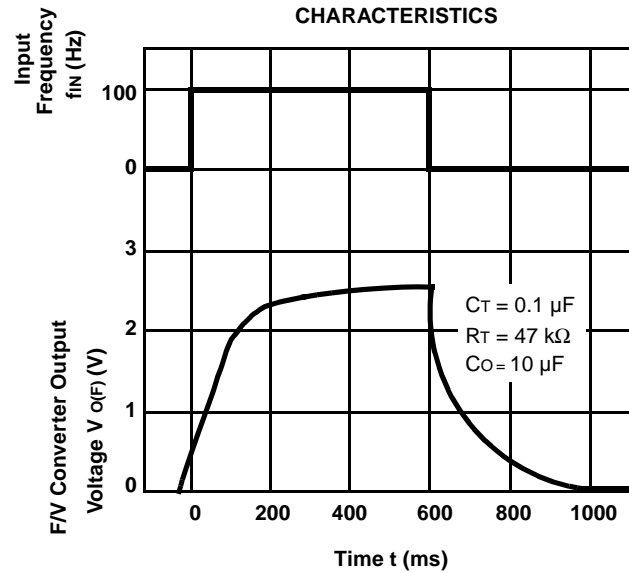

Fig. 9

F/V CONVERTER TRANSMISSION CHARACTERISTICS



FUJITSU LIMITED

For further information please contact:

Japan

FUJITSU LIMITED
Corporate Global Business Support Division
Electronic Devices
KAWASAKI PLANT, 1015, Kamikodanaka
Nakahara-ku, Kawasaki-shi
Kanagawa 211, Japan
Tel: (044) 754-3753
Fax: (044) 754-3329

North and South America

FUJITSU MICROELECTRONICS, INC.
Semiconductor Division
3545 North First Street
San Jose, CA 95134-1804, U.S.A.
Tel: (408) 922-9000
Fax: (408) 432-9044/9045

Europe

FUJITSU MIKROELEKTRONIK GmbH
Am Siebenstein 6-10
63303 Dreieich-Buchsschlag
Germany
Tel: (06103) 690-0
Fax: (06103) 690-122

Asia Pacific

FUJITSU MICROELECTRONICS ASIA PTE. LIMITED
No. 51 Bras Basah Road,
Plaza By The Park,
#06-04 to #06-07
Singapore 189554
Tel: 336-1600
Fax: 336-1609

F9601

© FUJITSU LIMITED Printed in Japan

All Rights Reserved.

Circuit diagrams utilizing Fujitsu products are included as a means of illustrating typical semiconductor applications. Complete information sufficient for construction purposes is not necessarily given.

The information contained in this document has been carefully checked and is believed to be reliable. However, Fujitsu assumes no responsibility for inaccuracies.

The information contained in this document does not convey any license under the copyrights, patent rights or trademarks claimed and owned by Fujitsu.

Fujitsu reserves the right to change products or specifications without notice.

No part of this publication may be copied or reproduced in any form or by any means, or transferred to any third party without prior written consent of Fujitsu.

The information contained in this document are not intended for use with equipments which require extremely high reliability such as aerospace equipments, undersea repeaters, nuclear control systems or medical equipments for life support.