



Micro Commercial Components

Micro Commercial Components
 20736 Marilla Street Chatsworth
 CA 91311
 Phone: (818) 701-4933
 Fax: (818) 701-4939

PB62F

Features

- Low Forward Voltage
- Any Mounting Position
- Silver Plated Copper Leads
- Surge Overload Rating Of 150 Amps

6 Amp Fast Recovery Bridge Rectifier 200 Volts

Maximum Ratings

- Operating Temperature: -55°C to +125°C
- Storage Temperature: -55°C to +150°C

Microsemi Catalog Number	Device Marking	Maximum Recurrent Peak Reverse Voltage	Maximum RMS Voltage	Maximum DC Blocking Voltage
PB62F	PB62F	200V	140V	200V

Electrical Characteristics @ 25°C Unless Otherwise Specified

Average Forward Current	$I_{F(AV)}$	6.0A	$T_J = 50^\circ\text{C}$
Peak Forward Surge Current	I_{FSM}	150A	8.3ms, half sine
Maximum Forward Voltage Drop Per Element	V_F	1.30V	$I_{FM} = 3.0A;$ $T_J = 25^\circ\text{C}^*$
Maximum DC Reverse Current At Rated DC Blocking Voltage	I_R	10µA 1 mA	$T_J = 25^\circ\text{C}$ $T_J = 100^\circ\text{C}$
Maximum Reverse Recovery Time PB62F	T_{rr}	200ns	$I_F=0.5A, I_R=1.0A,$ $I_{rr}=0.25A$

*Pulse test: Pulse width 300 µsec, Duty cycle 1%

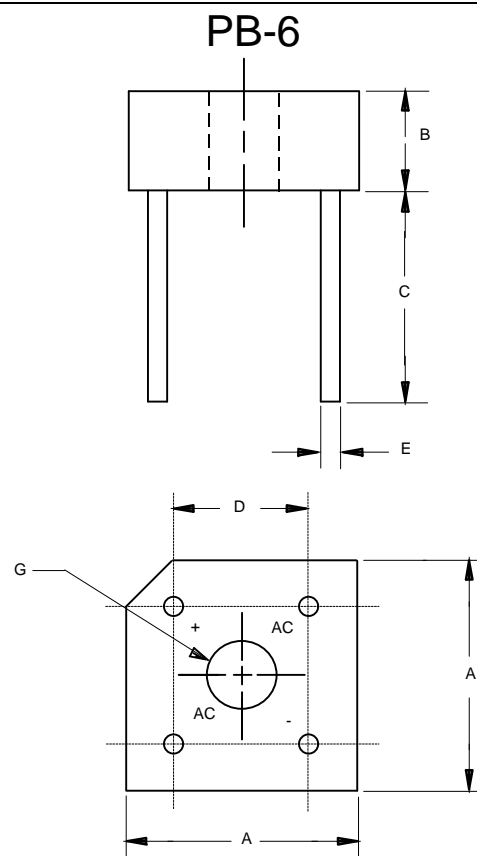

DIM	INCHES		MM		NOTE
	MIN	MAX	MIN	MAX	
A	.578	.618	14.69	15.71	2PL
B	.230	.270	5.84	6.86	
C	.750	---	19.10	---	
D	.405	.444	10.30	11.30	2PL
E	.038	.042	0.97	1.07	4PL/TYP
G	.145	---	3.70	---	∅

PB62F

Figure 1
Typical Forward Characteristics

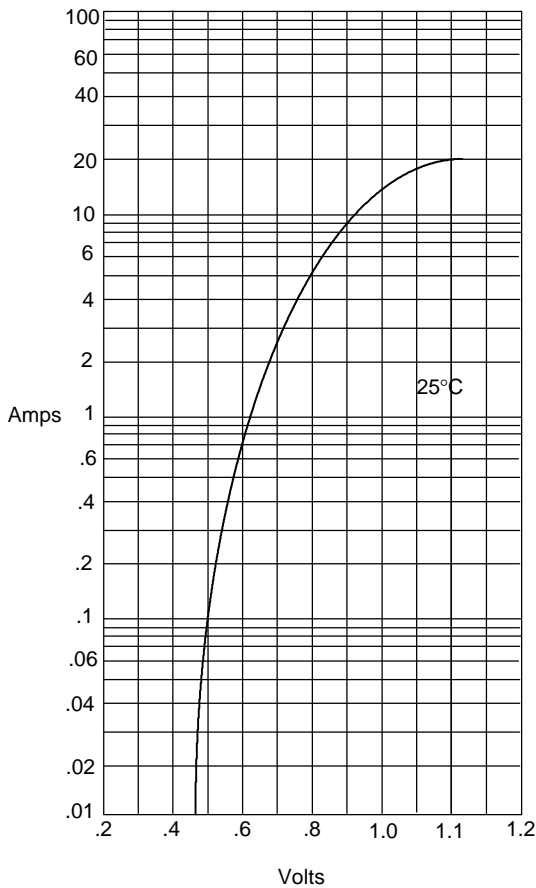

Instantaneous Forward Current - Amperes versus
Instantaneous Forward Voltage - Volts

Figure 2
Typical Reverse Characteristics

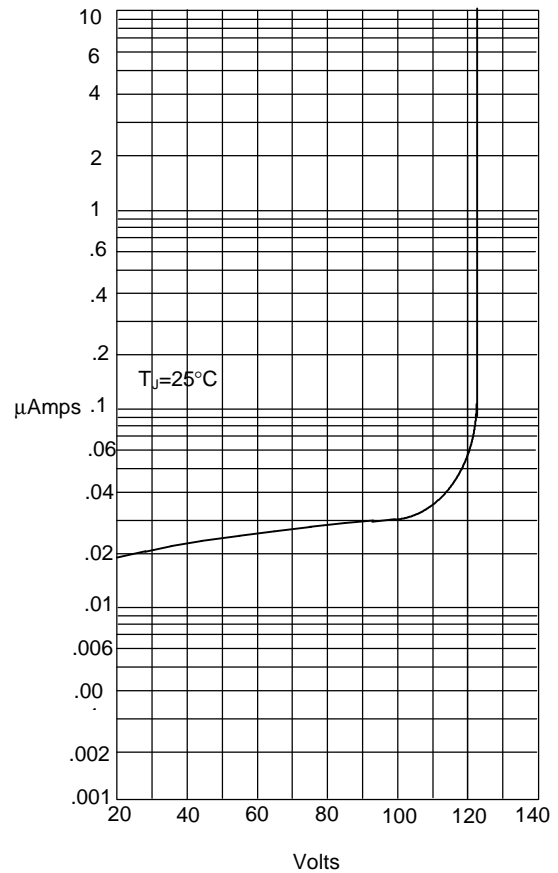

Instantaneous Reverse Leakage Current - MicroAmperes versus
Percent Of Rated Peak Reverse Voltage - Volts

Figure 3
Forward Derating Curve

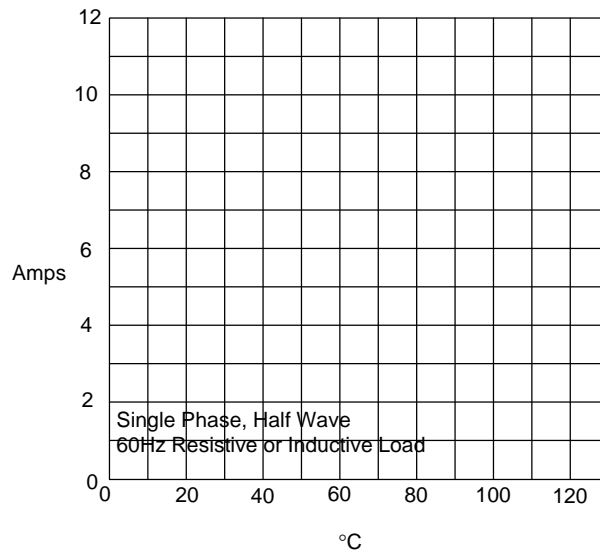

Average Forward Rectified Current - Amperes versus
Ambient Temperature - °C

Figure 4
Peak Forward Surge Current

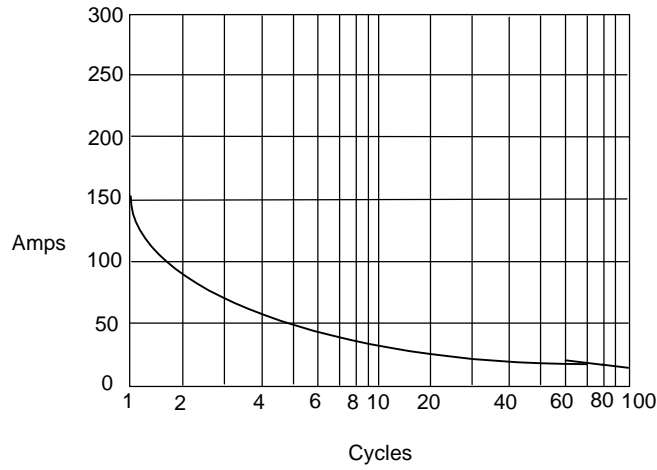

Peak Forward Surge Current - Amperes versus
Number Of Cycles At 60Hz - Cycles

Figure 5
Reverse Recovery Time Characteristic And Test Circuit Diagram

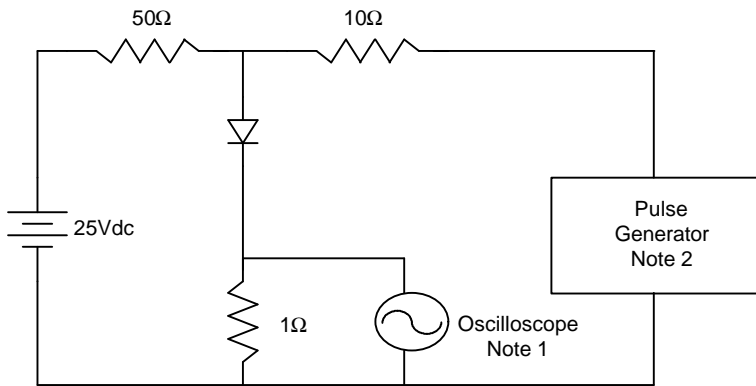

- Notes:
1. Rise Time = 7ns max.
Input impedance = 1 megohm, 22pF
 2. Rise Time = 10ns max.
Source impedance = 50 ohms
 3. Resistors are non-inductive

