

Termination-Insensitive Mixer, 0.5 - 9 GHz

MDC-164

Features

- Intermodulation Ratio Insensitive to IF Port Mismatches
- Conversion Loss: 6.5 dB Typical Midband
- Maximum Input Power: 350 mW Max @ 25°C, Derated 3.5 mW/°C
- LO Power: +24 dBm Max.
- MIL-STD-883 Screening Available

Description

The unique design of the termination insensitive mixer (TIM) enables it to apply high reverse voltage to diodes during their “off” phase, in the LO cycle. This allows for higher power level performance with minimum distortion. In addition the TIM has internal loads that provide a good match and also absorb mixer generated LO frequency terms. Combined, these features give the mixer its insensitivity to external mismatches, plus superior VSWR.

C-3

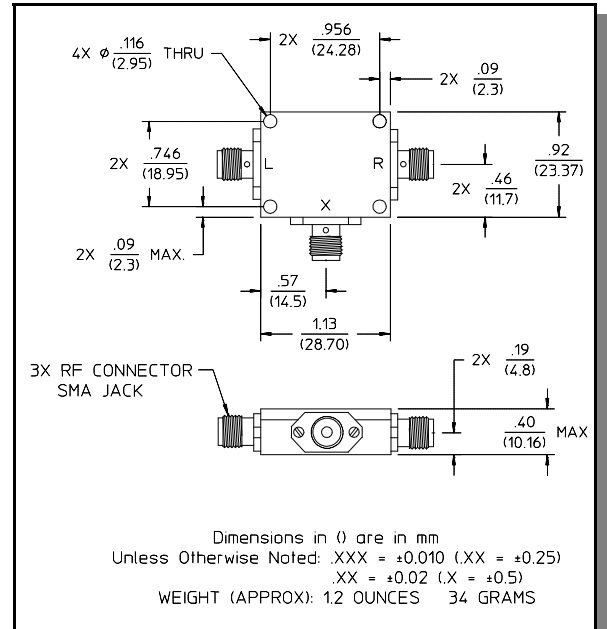

Electrical Specifications¹: T_A = -55°C to +85°C

Parameter	Test Conditions	Frequency	Units	Min	Typ	Max
Frequency Range	RF, LO Ports IF Port	0.5 - 9 10 - 2000	GHz MHz	— —	— —	— —
Conversion Loss ²		1 - 7 GHz 0.5 - 1 GHz 7 - 9 GHz	dB dB dB	— — —	— — —	8.5 10 11
Isolation	LO to RF	1.5 - 7 GHz 0.5 - 9 GHz	dB dB	17 13	— —	— —
	LO to IF	1.5 - 7 GHz 0.5 - 9 GHz	dB dB	20 17	— —	— —
	RF to IF	0.5 - 9 GHz	dB	17	—	—
RF Input	1 dB Compression 1 dB Desensitization	— —	dBm dBm	— —	+8 +6	— —
SSB Noise Figure	Within 1 dB of Conversion Loss Max	—	—	—	—	—
3rd Order Input Intercept		2.0 GHz 8.0 GHz	dBm dBm	— —	+15 +17	— —
3rd Order Intercept Degradation	@ IF Termination VSWR 3:1	—	dB	—	1.5	—

1. All specifications apply when operated at +13 dBm available LO power with 50 ohm source and load impedance.

2. For IF frequencies of 10 - 500 MHz and an RF to -10 dBm or lower.

3. Independent of sum frequency match.

This product contains elements protected by United States Patent Number 4,224,572.

Typical Performance Curves

Conversion Loss

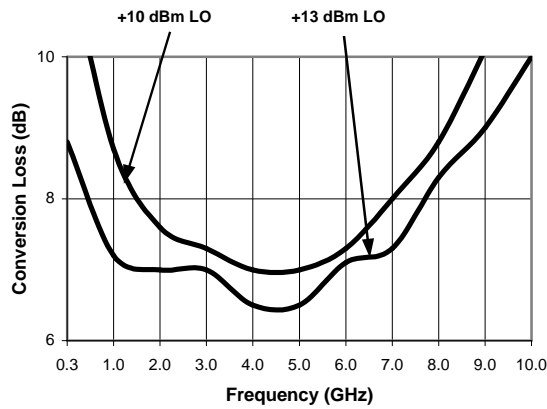

Conversion Loss vs. IF Port Termination³

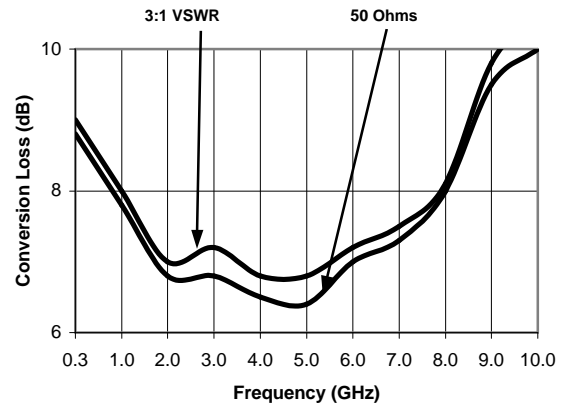

3rd Order Intercept

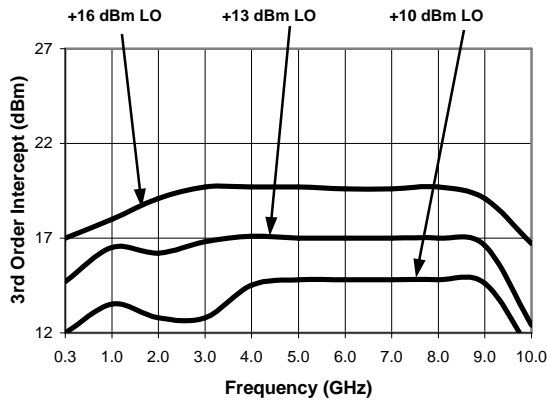

3rd Order Intercept vs. IF Port Termination³

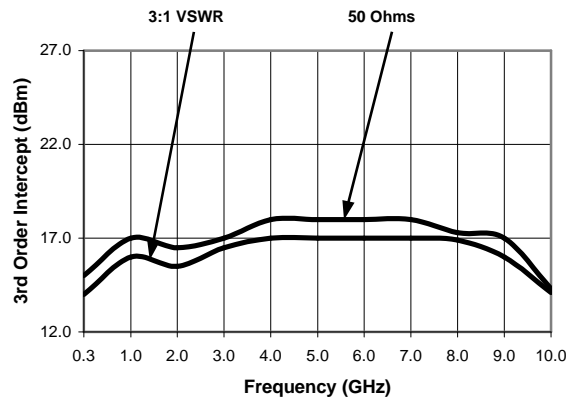

IF Port Response

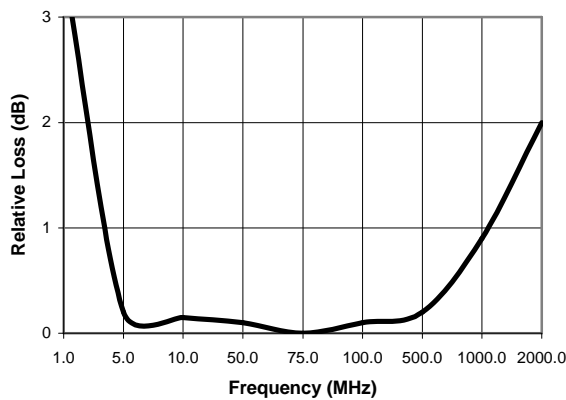

Isolation

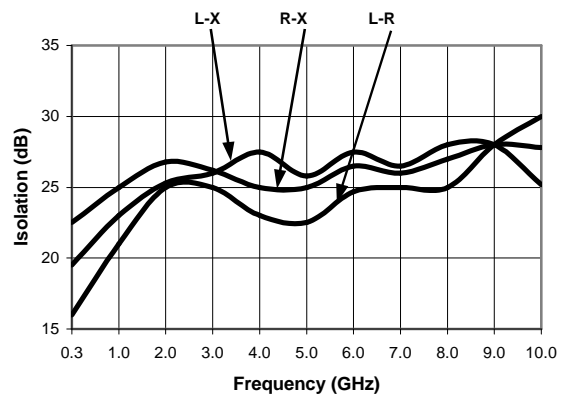

Specifications subject to change without notice.

- North America: Tel. (800) 366-2266
- Asia/Pacific: Tel.+81-44-844-8296, Fax +81-44-844-8298
- Europe: Tel. +44 (1344) 869 595, Fax+44 (1344) 300 020

Visit www.macom.com for additional data sheets and product information.



Ordering Information

Part Number	Package
MDC-164 SMA	C-3

Specifications subject to change without notice.

- **North America:** Tel. (800) 366-2266
- **Asia/Pacific:** Tel.+81-44-844-8296, Fax +81-44-844-8298
- **Europe:** Tel. +44 (1344) 869 595, Fax+44 (1344) 300 020

Visit www.macom.com for additional data sheets and product information.

tyco / Electronics

M/A-COM³