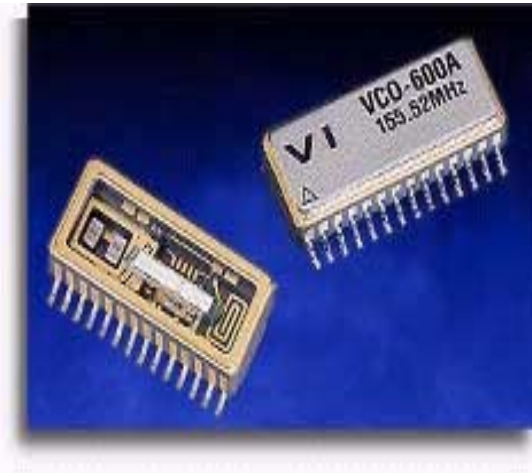


## **VCO-600A**

### **Voltage Controlled Saw Oscillator**



The VCO600A Voltage Controlled SAW Oscillator

### **Features**

- Output Frequency @ 155 MHz to 1 GHz
- Low jitter, 3pS rms for 622.080 MHz version and 6pS rms (typical) for 155 MHz version
- Ideal for clock smoothing, frequency translation, clock and data retiming applications
- 10K ECL, PECL logic levels with fast transition times
- Complementary outputs
- Low profile, surface mount package
- Output disable feature
- Low-frequency clock through feature
- Miniature hermetically sealed ceramic surface-mount package (SO-28, approx.0.7in. x 0.3in)

### **Applications**

- OC192/OC48/OC12 Clock Smoothing
- Frequency Translation

### **Description**

The VCO600A is a SAW stabilized, voltage controlled oscillator that operates at the fundamental frequency of the internal SAW filter. This filter is a high stability, high-Q quartz device that enables the circuit to achieve low phase jitter performance over a wide operating temperature range. The oscillator is housed in a hermetically sealed 28-lead surface mount package. It has a unique output disable and clock through feature to facilitate on-board testing.

# VCO-600A Voltage Controlled SAW Oscillator

## Pin Information

Pin	Symbol	Function	Top View of Package
2,12,27	V <sub>CC</sub>	Positive Supply	
4	CLKIN <sup>1</sup>	Test Clock In	
5,6,7,8	NC	No Connect	
10	V <sub>EE</sub>	Negative Supply	
17	V <sub>BW</sub> <sup>2</sup>	Modulation Bandwidth Adjust	
19	V <sub>C</sub>	Control Voltage	
21	OD <sup>3</sup>	Output Disable	
23	CLKOUT	ECL Output	
25	CLKOUT	Complementary ECL Output	
1,3,9,11,13,14,15,16,18,20,22,24,26,28	GND	Case and Circuit Ground	

1. By setting OD low, a test signal may be applied at CLKIN and fed through the VCO-600A to both the CLKOUT and CLKOUT to facilitate on board testing. The test signal input applied at CLKIN may be either an ECL or sinewave input (up to 1Vpp, AC coupled). CLKIN is biased internally to V<sub>BB</sub> (V<sub>cc</sub>-1.3V)

2. An optional capacitor to ground can be placed on VBW to reduce the modulation bandwidth for narrow bandwidth phase-lock loop applications. The modulation bandwidth will be approximately  $1/(12000 \cdot C)$  Hz, where C is equal to the capacitance in Farads. If the optional capacitor is not utilized, VBW becomes a no connect (NC) and the modulation bandwidth will be approximately equal to the nominal device frequency +1200.

3. By setting OD low, the outputs are disabled and CLKOUT is held Low while CLKOUT is held High. The threshold for OD is 1.4V above V<sub>EE</sub>. OD should not be driven above mid supply and during normal operation, should be left floating (use with an open collector or 3-State gate for interfacing with standard logic). If the OD feature is used during normal operation, then CLKIN should be tied through 10K $\Omega$  to GND to avoid any possibility of chatter on the CLKOUT outputs.

## Performance Characteristics

Parameter	Symbol	Minimum	Typical	Maximum	Units
Center Frequency, <i>see ordering information</i>	F <sub>N</sub>	155		1000	MHz
Operating Temperature	T <sub>OP</sub>	-40	25	+85	°C
Supply Current	I <sub>EE</sub>		55	70	mA
Supply Voltage <sup>1</sup>	V <sub>EE</sub>	-4.5	-5	-5.5	V
Absolute Pull Range (V <sub>c</sub> = -0.5 to -4.5)	APR	±50	-	-	ppm
Positive Gain Transfer (freq vs V <sub>c</sub> ) 155.520MHz	K <sub>V</sub>	175	350	700	ppm/V
Positive Gain Transfer (freq vs V <sub>c</sub> ) 622.080MHz	K <sub>V</sub>	60	135	290	ppm/V
Linearity	Lin		±3		%
Frequency Stability, -40 to 85 wrt 25°C	F <sub>STAB</sub>		±150		ppm
Output Level Low <sup>2</sup>	V <sub>OL</sub>	-1.95	-	-1.63	V
Output Level High <sup>2</sup>	V <sub>OH</sub>	-0.98	-	-0.75	V
Output Rise Time <sup>3</sup>	t <sub>R</sub>	100	250	400	pS
Output Fall Time <sup>3</sup>	t <sub>F</sub>	100	250	400	pS
Spurious Suppression		-50	-60		dB
Data Symmetry	SYM	45	49/51	55	%
Control Voltage Input Impedance	Z <sub>c</sub>	8	10	12	K $\Omega$
Control Voltage Modulation Bandwidth <sup>4</sup>	BW	-	500	-	kHz
Control Voltage Range	V <sub>C</sub>	V <sub>EE</sub>	-	V <sub>CC</sub>	V
Output Current	I <sub>OUT</sub>	-	-	20	mA
Storage Temperature	T <sub>S</sub>	-55	-	125	°C
Soldering Temp./Time	T <sub>LS</sub>	-	-	240/10	°C/S

1. The VCO-600A may be configured for PECL operation. All outputs and inputs including V<sub>C</sub> are referenced to V<sub>cc</sub>

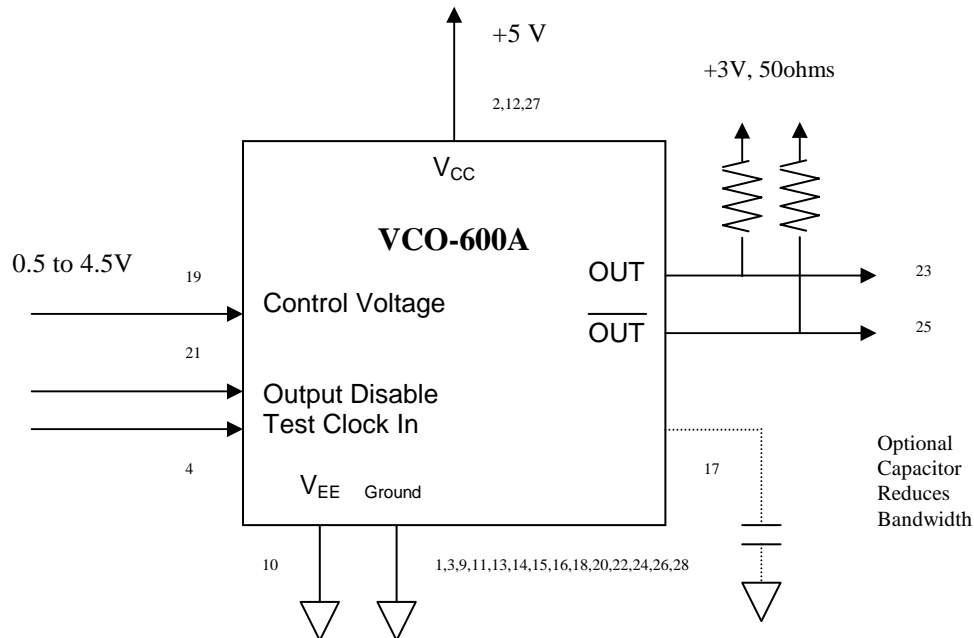
2. Output Levels are standard 10K ECL and are fully 100K ECL compatible.

3. Transition times are measured from 20% to 80% of a full 10K ECL level swing.

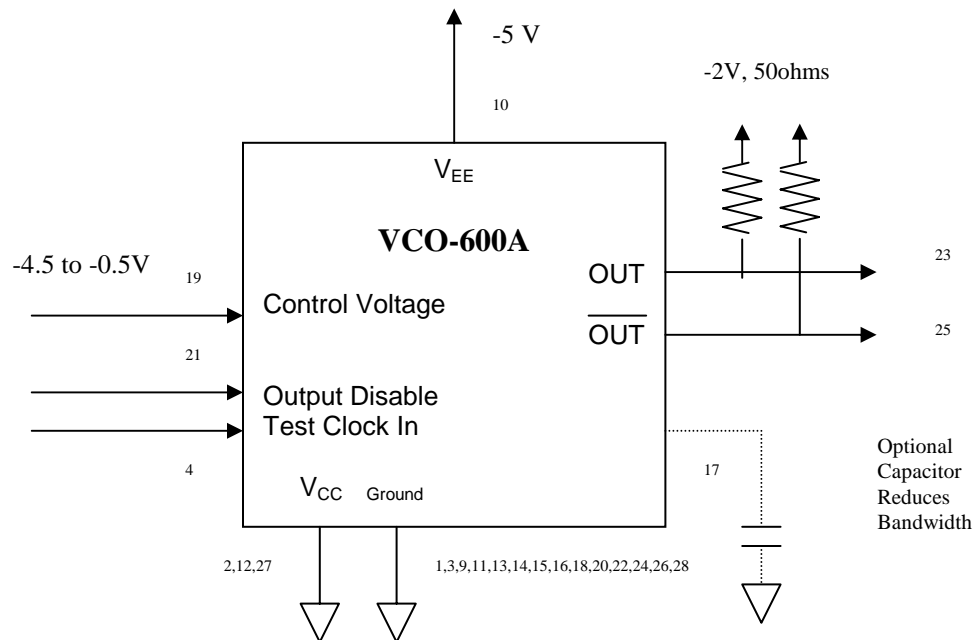
4. The modulation bandwidth is a function of nominal center frequency and may be adjusted down through the use of an external capacitor on pin 17. Please see Figure 1 and Figure 2 along with Notes 1, 2 and 3.

Offset from Carrier	100 Hz	1 kHz	10 kHz	100 kHz	1 MHz
VCO600A 622.080	-50	-80	-110	-130	-145

# VCO-600A Voltage Controlled SAW Oscillator



**Figure 1. PECL Operation**



**Figure 2. ECL Operation**

1. By setting OD low, a test signal may be applied at CLKIN and fed through the VCO-600A to both the CLKOUT and CLKOUT to facilitate on board testing. The test signal input applied at CLKIN may be either an ECL or sinewave input (up to 1Vpp, AC coupled). CLKIN is biased internally to VBB (Vcc-1.3V)
2. An optional bandwidth will be approximately  $1/(12000 \cdot C)$  Hz, where C is equal to the capacitance in Farads. If the optional capacitor is not utilized, VBW becomes a no connect (NC) and the modulation bandwidth will be approximately equal to the nominal device frequency  $\pm 1200$ .
3. By setting OD low, the outputs are disabled and CLKOUT is held Low while CLKOUT is held High. The threshold for OD is 1.4V above VEE. OD should not be driven above mid supply and during normal operation, should be left floating (use with an open collector or 3-State gate for interfacing with standard logic). If the OD feature is used during normal operation, then CLKIN should be tied through 10K $\Omega$  to GND to avoid any possibility of chatter on the CLKOUT outputs

## VCO-600A Voltage Controlled SAW Oscillator

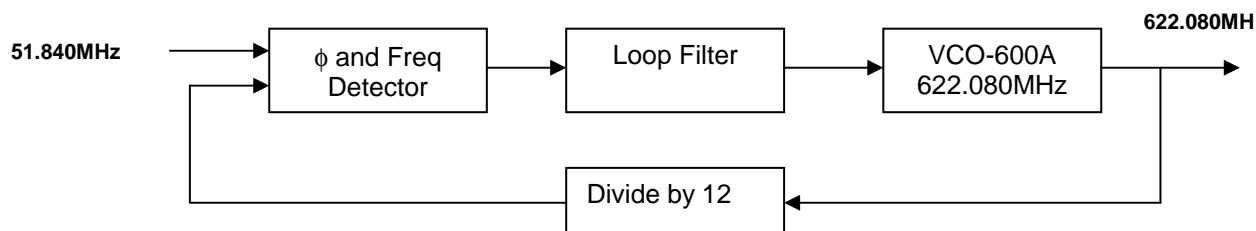


Figure 3. Typical Frequency Translation Diagram

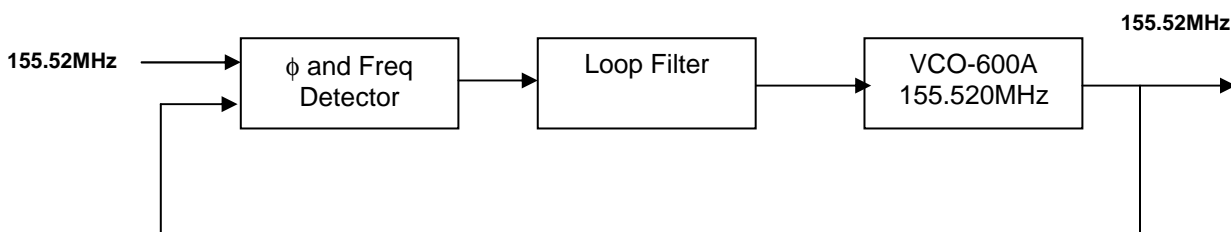


Figure 4. Typical Clock Smoothing Diagram

### Absolute Maximum Ratings

Stresses in excess of the absolute maximum ratings can permanently damage the device. Functional operation is not implied at these or any other conditions in excess of conditions represented in the operational sections of this data sheet. Exposure to absolute maximum ratings for extended periods may adversely affect device reliability.

Table 4. Absolute Maximum Ratings			
Parameter	Symbol	Ratings	Unit
Power Supply	$V_{EE}$	-8 to 0	V
Output Current <sup>1</sup>	I <sub>out</sub>	20	mA
Output Current <sup>2</sup>	I <sub>out</sub>	50	mA
Voltage Control Range <sup>1</sup>	$V_C$	$V_{EE}$ to $V_{CC}$	V
Voltage Control Range <sup>2</sup>	$V_C$	$V_{EE}-0.5$ to $V_{CC}+0.5$	V

1 Limits beyond which performance can not be guaranteed.

2 Limits beyond which device life may be impaired.

### Qualification Conformance

The VCO-600A family has undergone, and passed, the following Mil-Std qualification.

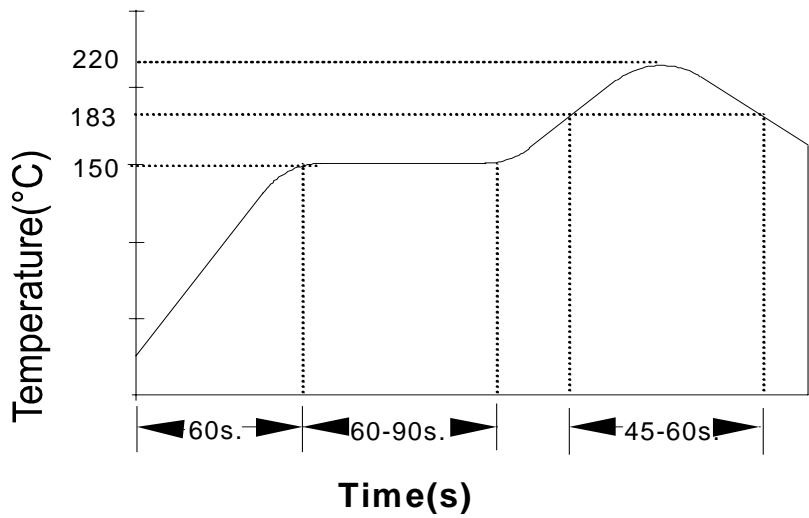
Table 5. Environmental Compliance	
Parameter	Conditions
Mechanical Shock	MIL-STD-883C 2002.3, TEST A
Mechanical Vibration	MIL-STD-883C 2007.1, TEST A
Solderability	MIL-STD-883C 2003.5,
Gross and Fine Leak	MIL-STD-883C, 1014.7, 100% Tested
Resistance to Solvents	MIL-STD-883C 2016

### Handling Precautions

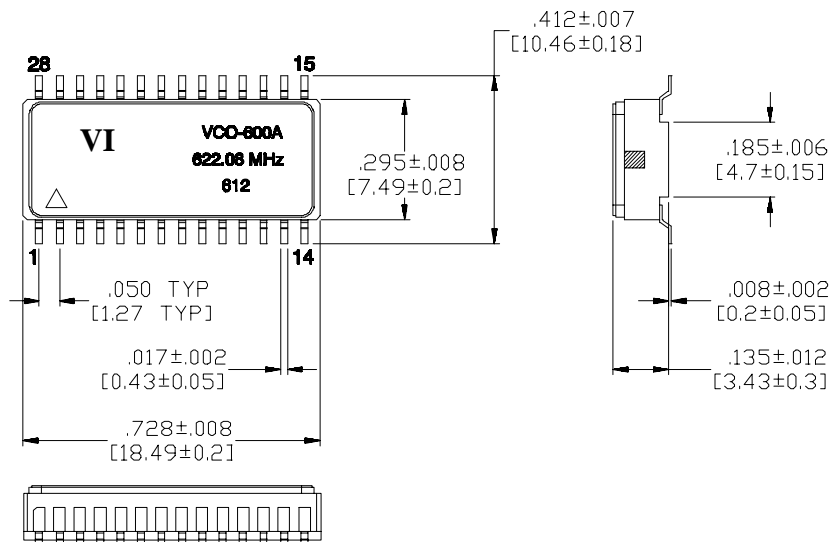
Although ESD protection circuitry has been designed into the the VCO-600A, proper precautions should be taken when handling and mounting. VI employs a human body model and a charged-device model (CDM) for ESD susceptibility testing and design protection evaluation. ESD thresholds are dependent on the circuit parameters used to define the model. Although no industry wide standard has been adopted for the CDM, a standard HBM of resistance=1.5Kohms and capacitance = 100pF is widely used and therefore can be used for comparison purposes.

Table 6. ESD Ratings	
Model	Minimum
Human Body Model	1000 V
Charged Device Model	1000 V

# VCO-600A Voltage Controlled SAW Oscillator

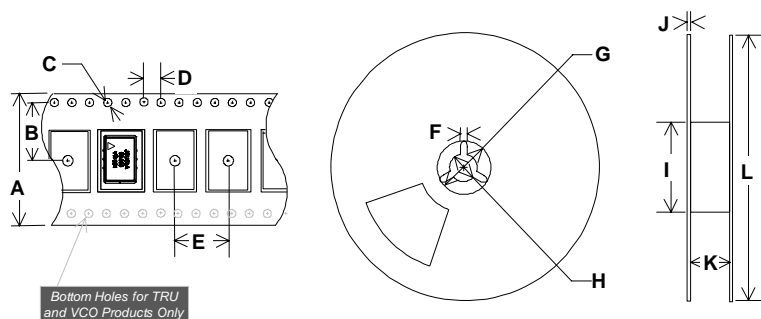


**Figure 5. Suggested IR profile**



**Figure 6. Outline Diagram**

# VCO-600A Voltage Controlled SAW Oscillator



**Figure 7. Tape Reel Drawing**

Table 7. Tape and Reel Dimensions (mm)													
Tape Dimensions						Reel Dimensions							# Per Reel
Product	A	B	C	D	E	F	G	H	I	J	K	L	Reel
VCO600A	32	14.2	1.5	4	16	1.78	21	13	100	5	33	330	200

## Ordering information

Table 8. Part number ordering information		
Part Number	Packaging	Comcode
VCO600A 155.52MHz	Tube	107040537
VCO600A 155.52MHz	Tape and Reel	407611896
VCO600A 278.528MHz	Tube	107316457
VCO600A 278.852MHz	Tape and Reel	
VCO600A 311.040MHz	Tube	107012551
VCO600A 311.040MHz	Tape and Reel	
VCO600A 368.640MHz	Tube	107237539
VCO600A 368.640MHz	Tape and Reel	407875244
VCO600A 622.080MHz	Tube	107012569
VCO600A 622.080MHz	Tape and Reel	407961762
VCO600A 666.5143MHz	Tube	330016544
VCO600A 666.5143MHz	Tape and Reel	330018383

## For Additional Information, Please Contact:



USA: Vectron International, 267 Lowell Rd, Hudson, NH 03051 . . . . Tel: 1-88-VECTRON-1

Fax: 1-888-FAX-VECTRON

EUROPE: . . . . . Tel: +49 (0) 3328-4784-17

Fax: +49 (0) 3328-4784-30

ASIA: . . . . . Tel: +86-21-28909740

Fax: +86-21-28909240

Vectron International reserves the right to make changes to the product(s) and/or information contained herein without notice. No liability is assumed as a result of their use or application. No rights under any patent accompany the sale of any such product(s) or information.

VCO600A.DOC (REVISION DATE: 11/23/04)

Vectron International 267 Lowell Rd, Hudson NH 03051-4916 Tel:1-88-VECTRON-1 e-mail vectron@vectron.com