

# Three Phase Rectifier Bridge

$I_{dAV} = 70 \text{ A}$   
 $V_{RRM} = 800-1600 \text{ V}$

Preliminary data

$V_{RSM}$	$V_{RRM}$	Type
$V_{DSM}$	$V_{DRM}$	
V	V	
800	800	xxx 70-08io7
1200	1200	xxx 70-12io7
1400	1400	xxx 70-14io7
1600	1600	xxx 70-16io7

xxx = type

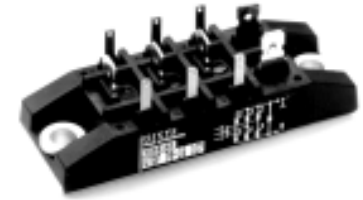
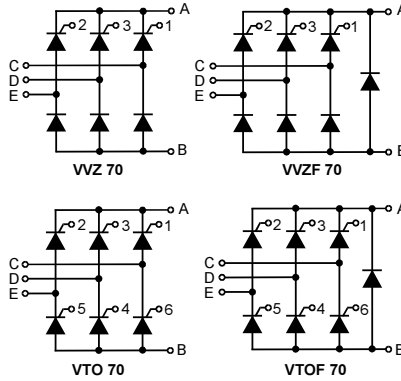

Symbol	Test Conditions	Maximum Ratings	
$I_{dAV}$ *	$T_K = 85^\circ\text{C}$ , module	70	A
$I_{dAVM}$ *	module	70	A
$I_{FRMS}$ , $I_{TRMS}$	per leg	36	A
$I_{FSM}$ , $I_{TSM}$	$T_{VJ} = 45^\circ\text{C}$ ; $V_R = 0 \text{ V}$	$t = 10 \text{ ms}$ (50 Hz), sine	550 A
		$t = 8.3 \text{ ms}$ (60 Hz), sine	600 A
$I^2t$	$T_{VJ} = T_{VJM}$ ; $V_R = 0 \text{ V}$	$t = 10 \text{ ms}$ (50 Hz), sine	500 A
		$t = 8.3 \text{ ms}$ (60 Hz), sine	550 A
$(di/dt)_{cr}$	$T_{VJ} = 125^\circ\text{C}$ ; $f = 50 \text{ Hz}$ , $t_p = 200 \mu\text{s}$ ; $V_D = 2/3 V_{DRM}$ ; $I_G = 0.3 \text{ A}$ ; $di_G/dt = 0.3 \text{ A}/\mu\text{s}$	repetitive, $I_T = 50 \text{ A}$	150 A/ $\mu\text{s}$
		non repetitive, $I_T = 1/2 \cdot I_{dAV}$	500 A/ $\mu\text{s}$
$(dv/dt)_{cr}$	$T_{VJ} = T_{VJM}$ ; $V_{DR} = 2/3 V_{DRM}$ ; $R_{GK} = \infty$ ; method 1 (linear voltage rise)		1000 V/ $\mu\text{s}$
$V_{RGM}$		10	V
$P_{GM}$	$T_{VJ} = T_{VJM}$ ; $I_T = I_{TAVM}$	$t_p = 30 \mu\text{s}$	$\leq 10 \text{ W}$
		$t_p = 500 \mu\text{s}$	$\leq 5 \text{ W}$
		$t_p = 10 \text{ ms}$	$\leq 1 \text{ W}$
$P_{GAVM}$		0.5	W
$T_{VJ}$		-40...+125	$^\circ\text{C}$
$T_{VJM}$		125	$^\circ\text{C}$
$T_{stg}$		-40...+125	$^\circ\text{C}$
$V_{ISOL}$	50/60 Hz, RMS	$t = 1 \text{ min}$	2500 V~
	$I_{ISOL} \leq 1 \text{ mA}$	$t = 1 \text{ s}$	3000 V~
$M_d$	Mounting torque (M5) (10-32 UNF)		$5 \pm 15 \%$ Nm
			$44 \pm 15 \%$ lb.in.
Weight		50	g

### Features

- Package with copper base plate
- Isolation voltage 3000 V~
- Planar passivated chips
- Low forward voltage drop
- 1/4" fast-on power terminals

### Applications

- Supplies for DC power equipment
- Input rectifiers for PWM inverter
- Battery DC power supplies
- Field supply for DC motors

### Advantages

- Easy to mount with two screws
- Space and weight savings
- Improved temperature and power cycling capability
- Small and light weight

### Dimensions in mm (1 mm = 0.0394")

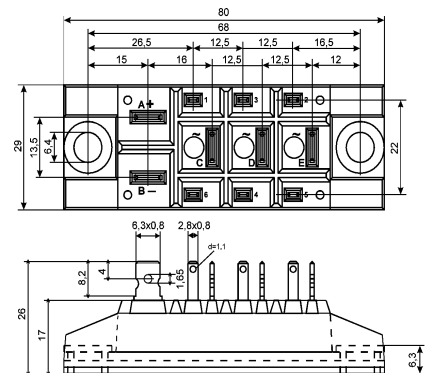

Data according to IEC 60747 refer to a single diode/thyristor unless otherwise stated

\* for resistive load at bridge output. IXYS reserves the right to change limits, test conditions and dimensions.

© 1999 IXYS All rights reserved

F2 - 51

**F2**

Symbol	Test Conditions	Characteristic Values
$I_D, I_R$	$T_{VJ} = T_{VJM}; V_R = V_{RRM}; V_D = V_{DRM}$	$\leq 5$ mA
$V_T$	$I_T = 80$ A; $T_{VJ} = 25^\circ\text{C}$	$\leq 1.64$ V
$V_{T0}$	For power-loss calculations only	0.85 V
$r_T$		11 m $\Omega$
$V_{GT}$	$V_D = 6$ V; $T_{VJ} = 25^\circ\text{C}$	$\leq 1.5$ V
	$T_{VJ} = -40^\circ\text{C}$	$\leq 1.6$ V
$I_{GT}$	$V_D = 6$ V; $T_{VJ} = 25^\circ\text{C}$	$\leq 100$ mA
	$T_{VJ} = -40^\circ\text{C}$	$\leq 200$ mA
$V_{GD}$	$T_{VJ} = T_{VJM}; V_D = 2/3 V_{DRM}$	$\leq 0.2$ V
$I_{GD}$		$\leq 5$ mA
$I_L$	$T_{VJ} = 25^\circ\text{C}; t_p = 10$ $\mu\text{s}$ $I_G = 0.45$ A; $di_G/dt = 0.45$ A/ $\mu\text{s}$	$\leq 450$ mA
$I_H$	$T_{VJ} = 25^\circ\text{C}; V_D = 6$ V; $R_{GK} = \infty$	$\leq 200$ mA
$t_{gd}$	$T_{VJ} = 25^\circ\text{C}; V_D = 1/2 V_{DRM}$ $I_G = 0.45$ A; $di_G/dt = 0.45$ A/ $\mu\text{s}$	$\leq 2$ $\mu\text{s}$
$t_q$	$T_{VJ} = T_{VJM}; I_T = 20$ A, $t_p = 200$ $\mu\text{s}$ ; $di/dt = -10$ A/ $\mu\text{s}$ typ. $V_R = 100$ V; $dv/dt = 15$ V/ $\mu\text{s}$ ; $V_D = 2/3 V_{DRM}$	250 $\mu\text{s}$
$R_{thJC}$	per thyristor / Diode; DC	0.9 K/W
	per module	0.15 K/W
$R_{thJH}$	per thyristor / Diode; DC	1.1 K/W
	per module	0.157 K/W
$d_s$	Creeping distance on surface	16.1 mm
$d_A$	Creepage distance in air	7.5 mm
$a$	Max. allowable acceleration	50 m/s <sup>2</sup>