

Powerex, Inc., 200 Hillis Street, Youngwood, Pennsylvania 15697-1800 (724) 925 7272

Rectifier Diode 1800 Amperes/Up to 3200 Volts

Description:

Powerex General Purpose Rectifiers are designed with high blocking voltage capability with low forward on-state voltage to minimize conduction losses. These are all-diffused, hermetic Pow-R-Disc devices which can be mounted using commercially available clamps and heatsinks..

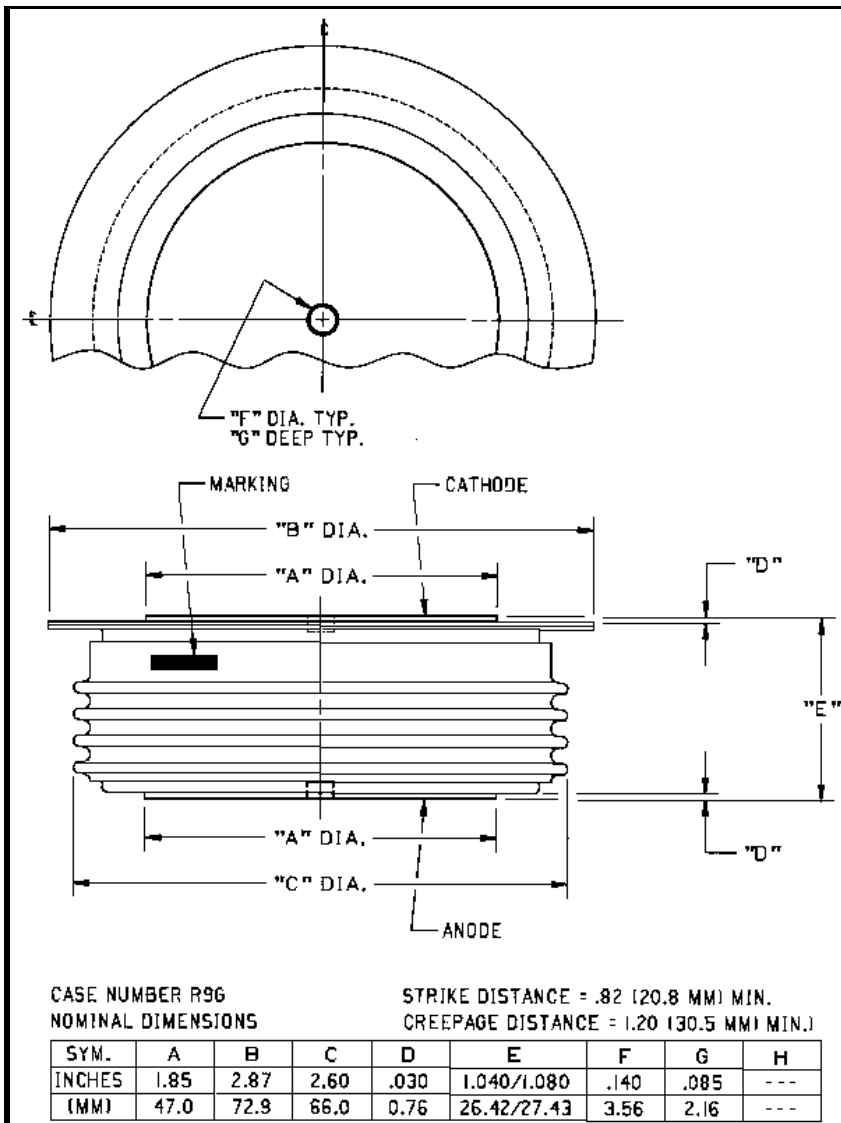

Features:

- Low On-State Voltage
- Low Thermal Impedance
- Hermetic Packaging
- Excellent Surge and I^2t Ratings

Applications:

- Power Supplies
- Motor Control
- Free Wheeling Diode

Ordering Information

Select the complete 10 digit device part number from the table below.

Type	Voltage V_{RRM}	Current $I_{T(av)}$	Recovery Time t_{rr}
R9G0	12	16	XX
	through		
	32		
	1200 V	1600 A	25 μ s
	through		typical
	3200 V		

Powerex, Inc., Hillis Street, Youngwood, Pennsylvania 15697-1800 (724) 925 7272

R9G0
Rectifier Diode

1800 Amperes / Up to 3200 Volts

Absolute Maximum Ratings

	Conditions	Symbol		Units
Repetitive Peak Reverse Blocking Voltage		V_{RRM}	up to 3200	V
Non-Repetitive Peak Reverse Blocking Voltage		V_{RSM}	$V_{RRM} + 100$	V
RMS Forward Current		$I_{F(RMS)}$	2825	A
Average Forward Current	180° Conduction, $T_C=110^{\circ}C$	$I_{F(AV)}$	1800	A
Peak Half Cycle Non-Repetitive Surge Current	$t = 8.3mS$, 100% V_{RRM} reapplied	I_{FSM}	21,500	A
Peak Half Cycle Non-Repetitive Surge Current	$t = 10mS$, 100% V_{RRM} reapplied	I_{FSM}	19,600	A
I^2t for Fusing for One Cycle		I^2t	1.925×10^6	A ² -sec
I^2t of Package	$t = 8.3mS$	I^2t	90×10^6	A ² -sec
Operating Junction Temperature		T_J	-40 to +175	°C
Storage Temperature		T_{stg}	-40 to +190	°C
Mounting Force	--	--	5000 to 6000	lb.
			2270 to 2700	kg
Module Weight, Typical	--	--	454	g
			1.0	lbs

Powerex, Inc., Hillis Street, Youngwood, Pennsylvania 15697-1800 (724) 925 7272

R9G0
Rectifier Diode

1800 Amperes / Up to 3200 Volts

Electrical and Thermal Characteristics, $T_J=25^\circ\text{C}$ unless otherwise specified

Characteristics	Symbol	Test Conditions	Min.	Typ.	Max	Units
Peak Reverse Leakage Current	I_{RRM}	$T_J=175^\circ\text{C}$, Rated V_{RRM}			150	mA
Peak On-State Voltage	V_{FM}	$T_J=25^\circ\text{C}$, $I_{FM}=1500\text{A}$			1.20	V
Threshold Voltage, Low-level	$V_{(TO)1}$	$T_J = 175^\circ\text{C}$, $I = 15\%I_{F(AV)}$ to $\rho I_{F(AV)}$.814	V
Slope Resistance, Low-level	r_{T1}				.224	m Ω
Threshold Voltage, High-level	$V_{(TO)2}$	$T_J = 175^\circ\text{C}$, $I = \rho I_{F(AV)}$ to I_{FSM}			1.03	V
Slope Resistance, High-level	r_{T2}				.198	m Ω
V_{FM} Coefficients, Full Range		$T_J = 175^\circ\text{C}$, $I = 15\%I_{F(AV)}$ to I_{FSM}		A = 2.06 B = -0.232 C = 0.000130 D = 0.0179		
		$V_{FM}=A + B \ln(I_{FM})+ C I_{FM}+ D \sqrt{I_{FM}}$				
Maximum Reverse Recovery Current	$I_{R(Rec)}$	$T_J = 175^\circ\text{C}$, $di/dt = -1 \text{ A}/\mu\text{s}$			70	A
		$T_J = 175^\circ\text{C}$, $di/dt = -10\text{A}/\mu\text{s}$			250	A
Typical Reverse Recovery Time	t_{rr}	$T_C = 25^\circ\text{C}$, $I_{FM} = 1500 \text{ A}$			25	μsec
		$di_R/dt = 25 \text{ A}/\mu\text{sec}$, $t_p = 190 \mu\text{sec}$				

Thermal Characteristics

Characteristics	Symbol	Min.	Typ.	Max.	Units
Thermal Resistance, Junction to Case	R_{TJC}	-----	-----	0.02	$^\circ\text{C}/\text{W}$
Thermal Resistance, Case to Sink Lubricated	R_{TCS}	-----	-----	0.0075	$^\circ\text{C}/\text{W}$

Maximum Transient Thermal Impedance

(Junction to Case)

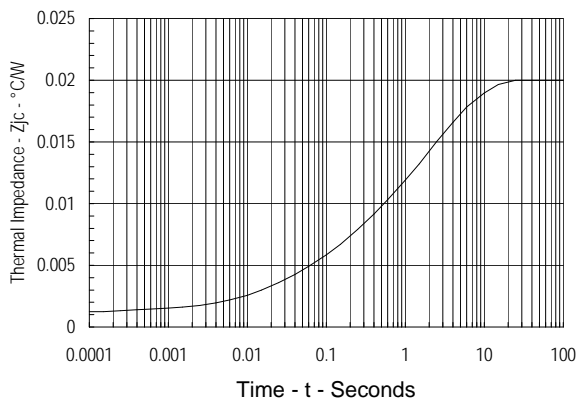
Maximum On-State Forward Voltage Drop

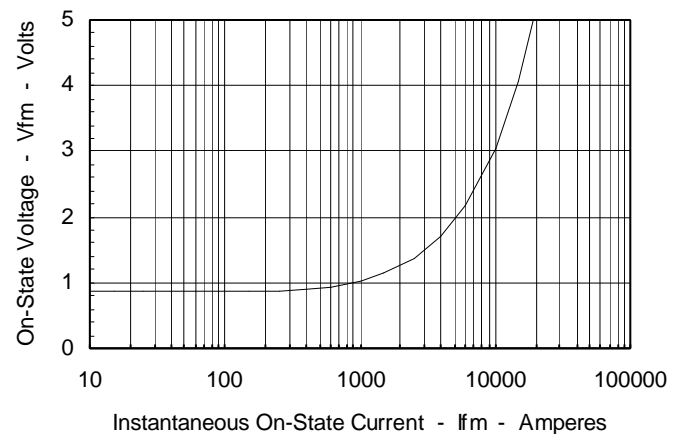
 ($T_J = 175^\circ\text{C}$)

Maximum On-State Power Dissipation

(Sinusoidal Waveform)

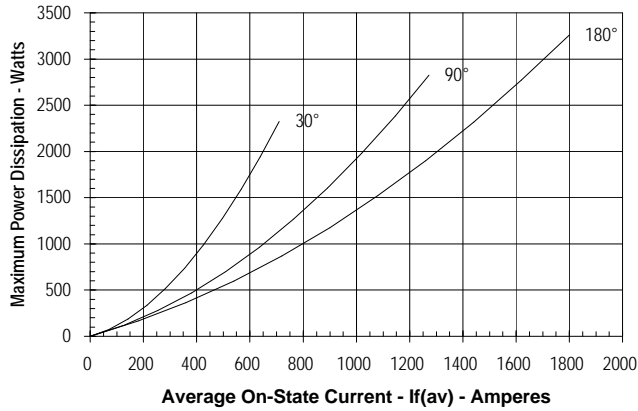

Maximum Allowable Case Temperature

(Sinusoidal Waveform)

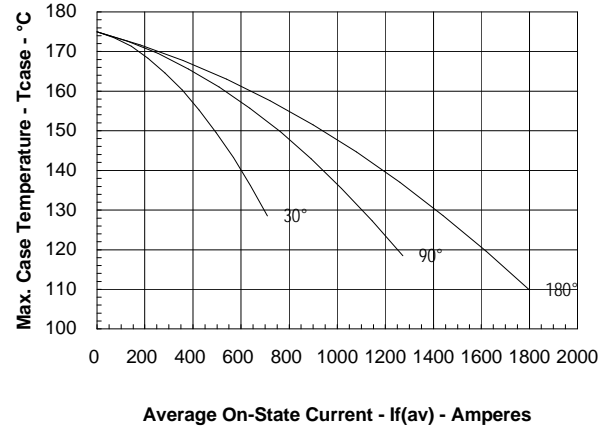

Maximum On-State Power Dissipation

(Rectangular Waveform)

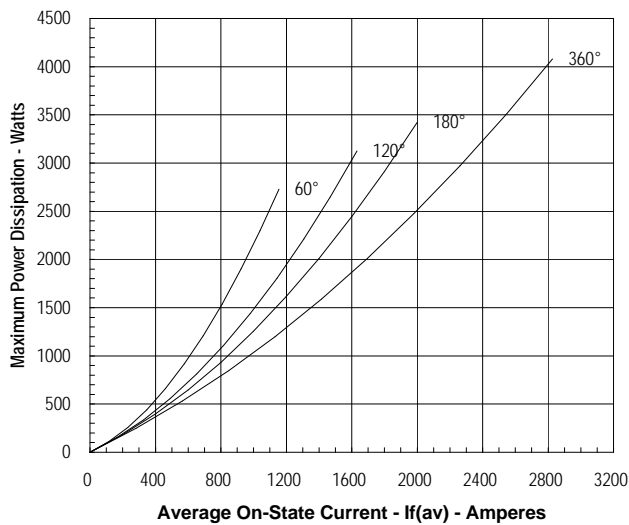

Maximum Allowable Case Temperature

(Rectangular Waveform)

