

PART NUMBER: VSD-500

DESCRIPTION: dc-dc converter

Features

- Protections: Short circuit/Over load/
Over voltage/ Over temperature
- 2000VAC I/O isolation
- Forced air cooling by built-in DC fan with speed control
- 100% full load burn-in test
- Built-in remote On-Off control
- Built-in remote sense function
- Output OK signal
- VSD-500L type input voltage design refers to LVD
- 3 year warranty



Model ^{1,3}	Input Voltage	Output Voltage	Output Current	Ripple ² & Noise	Regulation		Efficiency
					Load	Line	
VSD-500L-12	19~72V DC	12V DC	40 A	150mV	±0.5%	±0.5%	85%
VSD-500L-24	19~72V DC	24V DC	21 A	150mV	±0.5%	±0.5%	88%
VSD-500L-48	19~72V DC	48V DC	10.5 A	150mV	±0.5%	±0.5%	89%
VSD-500H-12	72~144V DC	12V DC	40 A	150mV	±0.5%	±0.5%	86%
VSD-500H-24	72~144V DC	24V DC	21 A	150mV	±0.5%	±0.5%	89%
VSD-500H-48	72~144V DC	48V DC	10.5 A	150mV	±0.5%	±0.5%	90%

Notes:

- 1 All parameters Not specifically mentioned are measured at 48VDC and 96VDC input, rated load and 25°C ambient temp.
- 2 Ripple & noise are measured at 20MHz of bandwidth by using a 12" twisted pair-wire terminated with a 0.1uF & 47uF parallel capacitor.
- 3 The power supply is considered a component which will be installed into final equipment. The final equipment must be re-confirmed that it still meets EMC directives.



PART NUMBER: VSD-500

DESCRIPTION: dc-dc converter

Input Voltage

Parameter	Conditions/Description	Min	Nom	Max	Units
Input voltage	L	19	48	72	DC
	H	72	120	144	DC

Output

Parameter	Conditions/Description	Min	Nom	Max	Units
DC Voltage adj.		11	12	15	VDC
		23	24	30	VDC
		46	48	60	VDC
Over Voltage Protection	12V	16		19	VDC
	24V	30.8		35.2	VDC
	48V	62		68	VDC
DC output power	12V		480		Watts
	24V		504		Watts
	48V		504		Watts
Voltage Tolerance	includes set up tolerance, line and load regulation.		±1%		
Hold up time			50		mS
Set up			500		mS

Protection Circuit

Parameter	Conditions/Description			
Input Fuse	Built-in ac fuse. A blown fuse usually indicates permanent damage to the power supply serviceable by factory only.			
Over temp.	Power supply shuts down when temperature is in excess of		90	°C
Overload	For all models. Type-shut down o/p voltage, re-power on to recover	105~125%		

PART NUMBER: VSD-500

DESCRIPTION: dc-dc converter

General and Safety

Parameter	Conditions/Description	Min	Nom	Max	Units
Operating temp.	(refer to output derating curve)	-20		60	°C
Storage temp.		-40		85	°C
Operating humid.	Non-condensing	20%		90%	RH
Storage humid.	Non-condensing	10%		95%	RH
Temperature coefficient		±0.02% / °C (0~50°C)			
EMI	EN55022(CISPR22) CLASS B				
Safety (EMC)	En61000-4-2, 3, 4, 6, 8, ENV50204 light industry level, criteria A. IEC60950-1 CB approved by TUV				
Vibration	2G 10min/i cycle, 60 min on X, Y and Z Axis	10		500	Hz
Withstand Voltage	I/P-O/P	2000			VDC
	I/P-FG	1500			VDC
	O/P-FG	500			VDC
Isolation Resistance	I/P-O/P, I/P-FG, O/P-FG	100mΩ min. / 500VDC			
Remote On/Off	Refer to Function manual				
Output OK Signal	Open collector signal low when PSU turns on, Max sink current: 10mA				
MTBF	196K hrs min., MIL-HDBK-217F(25°C)				

Mechanical

Parameter	Conditions/Description	Min	Nom	Max	Units
Weight				1150	grams
Enclosure	215(L) x 115(W) x 50(H) mm				

PART NUMBER: VSD-500

DESCRIPTION: dc-dc converter

Function Description of CN3

Pin No.	Function	Description
1	+S	Positive sensing. The +S signal should be connected to the positive terminal of the load. The +S and -S leads should be twisted in pair to minimize noise pick-up effect. The maximum line drop compensation is 0.5V.
2	-S	Negative sensing. The -S signal should be connected to the negative terminal of the load. The -S and +S leads should be twisted in pair to minimize noise pick-up effect. The maximum line drop compensation is 0.5V.
3	O/P OK	Open collector signal, referenced to pin4(GND). Low when PSU turns on. The maximum sink current is 10mA and the maximum external voltage is 13V.
4	GND	These pins connect to the negative terminal (-V).
5	RC	Remote ON/OFF
6	RCG	Remote ON/OFF ground

Function Manual
1.Remote ON/OFF

- (1) Remote ON/OFF control becomes available by applying voltage in CN3
- (2) Table 1.1 shows the specification of Remote ON/OFF function
- (3) Fig.1.2 shows the example to connect Remote ON/OFF control function

Table 1.1 Specification of Remote ON/OFF

Connection Method	Fig. 1.2(A)	Fig. 1.2(B)
Output on	SW Open	V=0~0.5Vdc
Output off	SW Close	V=2.5~5.5Vdc

Fig.1.2 Examples of connecting remote ON/OFF

(A) Using external voltage source

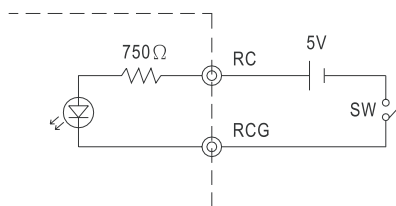

(B) Using external voltage source

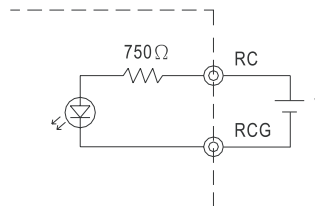
2.Output OK signal

"Output OK" is an open collector signal.

It indicates the output status of the PSU. It can operate in two ways : One is sinking current from external signal ; the other is sending out a voltage signal.

2-1 Sink current :

The maximum sink current is 10mA and the maximum external voltage is 13V.

2-2 Voltage signal :

Between O/P OK(pin3) and GND(pin4)	Output Status
0 ~ 0.5V	ON
12 ~ 13V	OFF

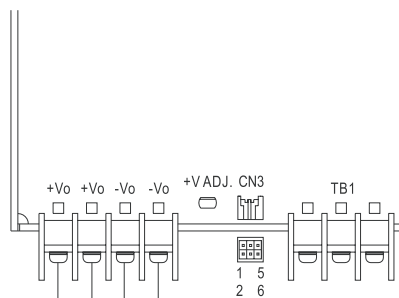

1	CN3	5
+S	O/P OK	RC
-S	GND	RCG
2		6

PART NUMBER: VSD-500

DESCRIPTION: dc-dc converter

3.Remote Sense

The remote sensing compensates voltage drop on the load wiring up to 0.5V.

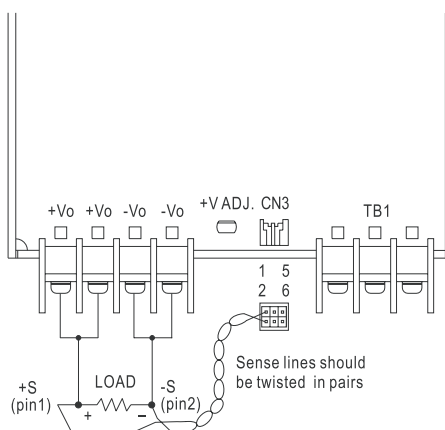

1	CN3	5
+S	O/POK	RC
-S	GND	RCG
2		6

PART NUMBER: VSD-500

DESCRIPTION: dc-dc converter

Mechanical Specification

Case No. 912A Unit:mm

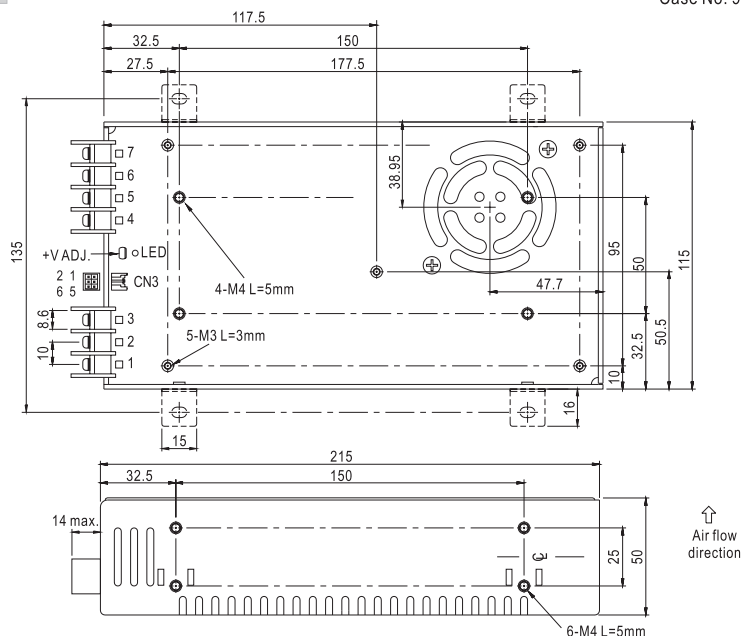

DC Input Terminal Pin No. Assignment

Pin No.	Assignment	Pin No.	Assignment
1	DC INPUT V+	4,5	-V
2	DC INPUT V-	6,7	+V
3	FG		

Control Pin No. Assignment (CN3) : JST B6B-PHDS or equivalent

Pin No.	Assignment	Pin No.	Assignment	Mating Housing	Terminal
1	+S	4	GND	JST PHDR-06VS or equivalent	JST SPHD-002T-P0.5 or equivalent
2	-S	5	RC		
3	OUTPUT OK	6	RCG		

Block Diagram

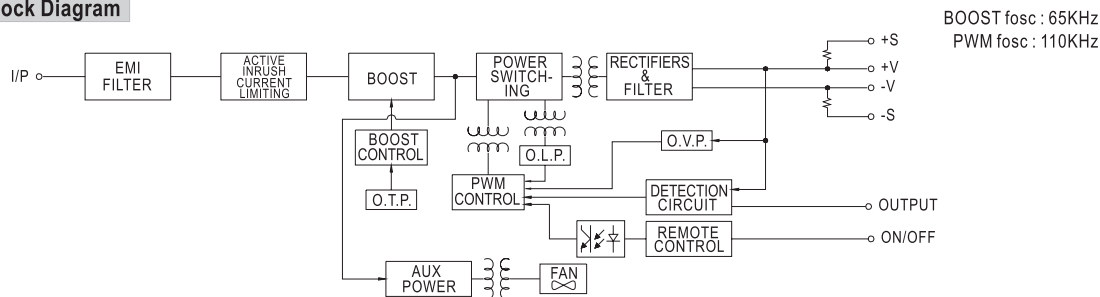

Derating Curve

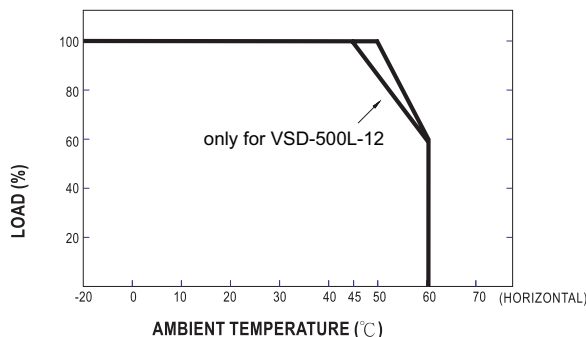

Static Characteristics

