

FSAV430

Low Voltage 1.1GHz 4 Channel 2:1 Video Switch

General Description

The FSAV430 is a high performance Quad SPDT (2-to-1 multiplexer/demultiplexer) video switch designed specifically for switching high definition YPbPr and computer RGB (up to UXGA) signals. The bandwidth of this device is 1.1GHz (Typ) which allows signals to pass with minimal edge and phase distortion. Image integrity is maintained with low crosstalk, high OFF-Isolation and low differential gain and phase. The low On Resistance (4.5Ω typical) minimizes signal insertion loss. Low voltage operation (3V), low power consumption (1uA maximum) and small scale packaging (including leadless DQFN) make this device ideal for a broad range of applications.

Features

- -40dB OFF Isolation at 30MHz
- -60dB non-adjacent channel crosstalk at 30MHz
- 4.5Ω typical On Resistance (R_{ON})
- -3dB bandwidth: 1.1GHz
- Low power consumption (1uA max)
- Control input: TTL compatible
- Bidirectional operation

Applications

- RGB Video Switch in LCD, plasma and projection displays
- DVD-RW

Ordering Code:

Order Number	Package Number	Package Description
FSAV430BQX (Note 1)	MLP016E	Pb-Free 16-Terminal Depopulated Quad Very-Thin Flat Pack No Leads (DQFN), JEDEC MO-241, 2.5 x 3.5mm
FSAV430QSC	MQA16A	16-Lead Quarter Size Small Outline Package (QSOP), JEDEC MO-137, 0.150" Wide
FSAV430MTC	MTC16	16-Lead Thin Shrink Small Outline Package (TSSOP), JEDEC MO-153, 4.4mm Wide

Devices also available in Tape and Reel. Specify by appending suffix letter "X" to the ordering code.
Pb-Free package per JEDEC J-STD-020B.

Note 1: DQFN package available in Tape and Reel only.

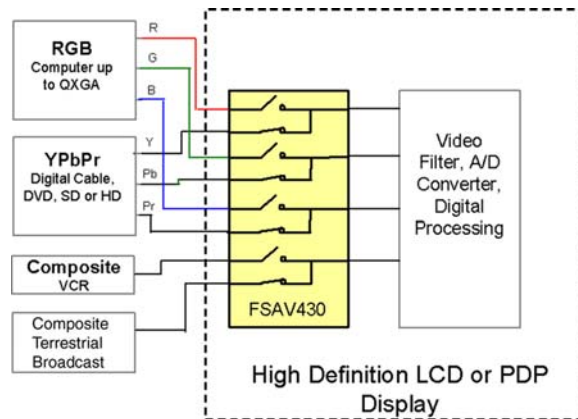

Analog Symbol

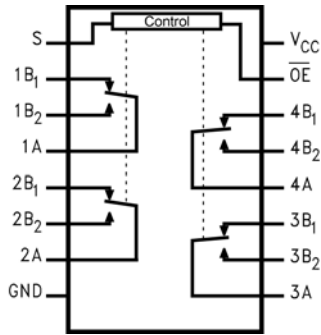

Connection Diagrams

Pin Assignments for QSOP and TSSOP

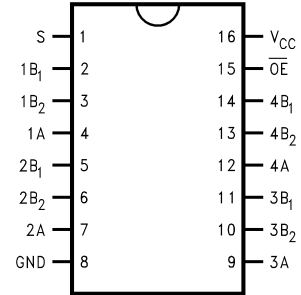

Pad Assignments for DQFN

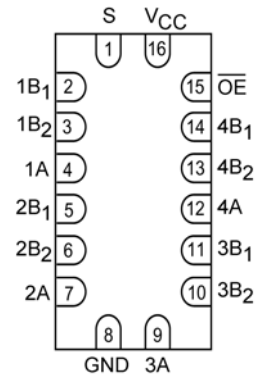

Pin Descriptions

Pin Name	Description
\overline{OE}	Bus Switch Enable
S	Select Input
A	Bus A
B ₁ -B ₂	Bus B

Truth Table

S	\overline{OE}	Function
X	H	Disconnect
L	L	A = B ₁
H	L	A = B ₂

Absolute Maximum Ratings (Note 2)

Supply Voltage (V_{CC})	-0.5V to +4.6V
DC Switch Voltage (V_S)	-0.5V to $V_{CC} + 0.05V$
DC Input Voltage (V_{IN}) (Note 3)	-0.5V to +4.6V
DC Input Diode Current (I_{IK}) $V_{IN} < 0V$	-50 mA
DC Output (I_{OUT}) Sink Current	128 mA
DC V_{CC}/GND Current (I_{CC}/I_{GND})	± 100 mA
Storage Temperature Range (T_{STG})	-65°C to +150 °C
ESD	
Human Body Model	4kV

Recommended Operating Conditions

(Note 4)

Power Supply Operating (V_{CC})	3.0V to 3.6V
Input Voltage (V_{IN})	0V to V_{CC}
Output Voltage (V_{OUT})	0V to V_{CC}
Input Rise and Fall Time (t_r, t_f)	
Switch Control Input	0 ns/V to 5 ns/V
Switch I/O	0 ns/V to DC
Free Air Operating Temperature (T_A)	-40 °C to +85 °C

Note 2: The Absolute Maximum Ratings are those values beyond which the safety of the device cannot be guaranteed. The device should not be operated at these limits. The parametric values defined in the Electrical Characteristics tables are not guaranteed at the absolute maximum rating. The Recommended Operating Conditions tables will define the conditions for actual device operation.

Note 3: The input and output negative voltage ratings may be exceeded if the input and output diode current ratings are observed.

Note 4: Unused control inputs must be held HIGH or LOW. They may not float.

DC Electrical Characteristics

Symbol	Parameter	V_{CC} (V)	$T_A = -40\text{ °C to }+85\text{ °C}$			Units	Conditions
			Min	Typ (Note 5)	Max		
	Analog Signal Range		0		2.0	V	
V_{IK}	Clamp Diode Voltage	3.0			-1.2	V	$I_{IN} = -18\text{ mA}$
V_{IH}	HIGH Level Input Voltage	3.0 - 3.6	2.0			V	
V_{IL}	LOW Level Input Voltage	3.0 - 3.6			0.8	V	
I_I	Input Leakage Current	3.6			± 1.0	μA	$0 \leq V_{IN} \leq 3.6V$
I_{OFF}	OFF-STATE Leakage Current	3.6			± 1.0	μA	$0 \leq A, B \leq V_{CC}$
R_{ON}	Switch On Resistance (Note 6)	3.0		5.0	7.0	Ω	$V_{IN} = 1.0V$ $R_I = 75\ \Omega, I_{ON} = 13\text{ mA}$
		3.0		4.5	6.0	Ω	$V_{IN} = 2.0V$ $R_I = 75\ \Omega, I_{ON} = 26\text{ mA}$
$R_{FLAT(ON)}$	On Resistance Flatness (Note 7)	3.0		1.0		Ω	$I_{OUT} = 13\text{ mA}, V_{IN} = 0\text{ to }V_{CC}$
I_{CC}	Quiescent Supply Current	3.6			1.0	μA	$V_{IN} = V_{CC}\text{ or }GND, I_{OUT} = 0$
ΔI_{CC}	Increase in I_{CC} per Input	3.6			30.0	μA	One Input at 3.0V Other Inputs at V_{CC} or GND

Note 5: Typical values are at $T_A = +25\text{ °C}$

Note 6: Measured by the voltage drop between A and B pins at the indicated current through the switch. On Resistance is determined by the lower of the voltages on the two (A or B) pins.

Note 7: Flatness is defined as the difference between the maximum and minimum value On Resistance over the specified range of conditions.

AC Electrical Characteristics

Symbol	Parameter	V _{CC} (V)	T _A = -40°C to +85°C			Units	Conditions	Figure Number
			Min	Typ (Note)	Max			
t _{ON}	Turn ON Time S-to-Bus A	3.0 to 3.6		4.8	7.0	ns	B _n = 2.0V	Figures 8, 9
	Output Enable Time OE-to-A	3.0 to 3.6		4.5	6.8			
t _{OFF}	Turn OFF Time S-to-Bus A	3.0 to 3.6		2.2	4.0	ns	B _n = 2.0V	Figures 8, 9
	Output Disable Time OE-to-A	3.0 to 3.6		2.2	4.0			
DG	Differential Gain	3.0 to 3.6		0.2		%	R _L = 75Ω, f = 3.58MHz	Figures 2, 3
DP	Differential Phase	3.0 to 3.6		0.1		Degree	R _L = 75Ω, f = 3.58MHz	Figures 2, 3
O _{IRR}	Non-Adjacent OFF-Isolation	3.0 to 3.6		-40.0		dB	f = 30MHz, R _L = 75Ω	Figures 4, 10
X _{TALK}	Non-Adjacent Channel Crosstalk	3.0 to 3.6		-60.0		dB	R _L = 75Ω, f = 30MHz	Figures 5, 11
BW	-3dB Bandwidth	3.0 to 3.6		1.1		GHz	R _L = 50Ω (DQFN)	Figures 1, 12
		3.0 to 3.6		800			R _L = 50Ω (QSOP and TSSOP)	
		3.0 to 3.6		650		MHz	R _L = 75Ω (DQFN)	
		3.0 to 3.6		600			R _L = 75Ω (QSOP and TSSOP)	

Note 8: Typical values are at V_{CC} = 3.3V and T_A = +25°C

Capacitance

Symbol	Parameter	T _A = -40°C to +85°C		Units	Conditions
		Typ (Note)			
C _{IN}	Control Pin Input Capacitance	2.5		pF	V _{CC} = 0V
C _{ON}	A/B ON Capacitance	12.0		pF	V _{CC} = 3.3V, OE = 0V
C _{OFF}	Port B OFF Capacitance	4.0		pF	V _{CC} and OE = 3.3V

Note 9: Typical values are at V_{CC} = 3.3V and T_A = +25°C

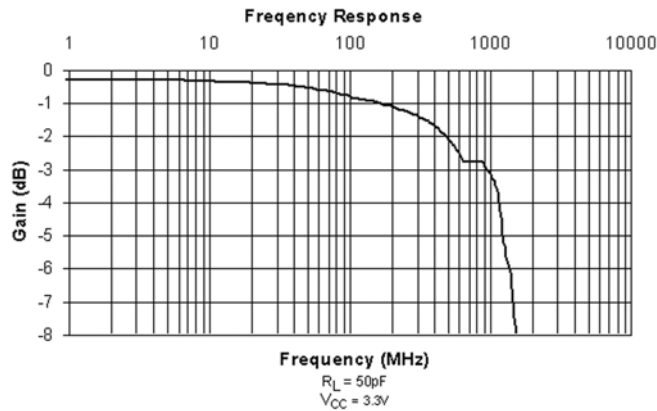

FIGURE 1. Gain vs. Frequency

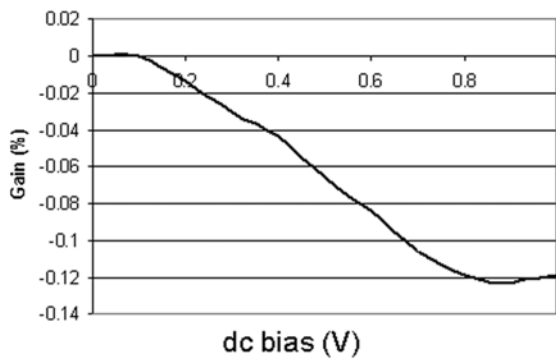

FIGURE 2. Differential Gain vs. dc bias

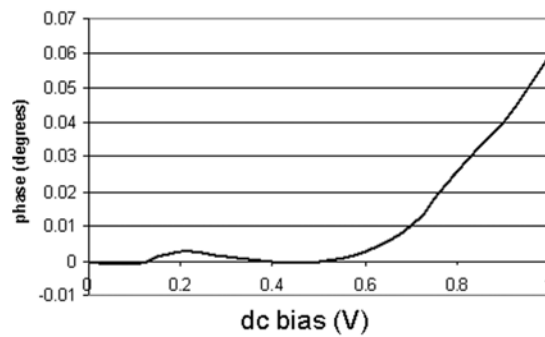

FIGURE 3. Differential Phase vs. dc bias

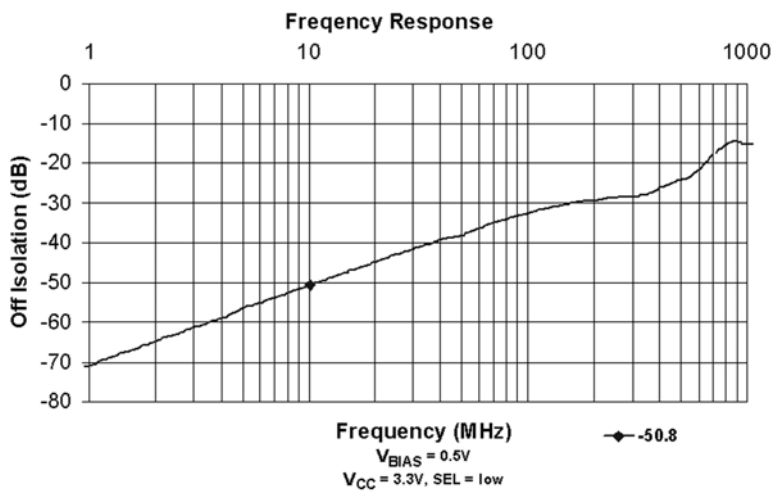

FIGURE 4. OFF Isolation

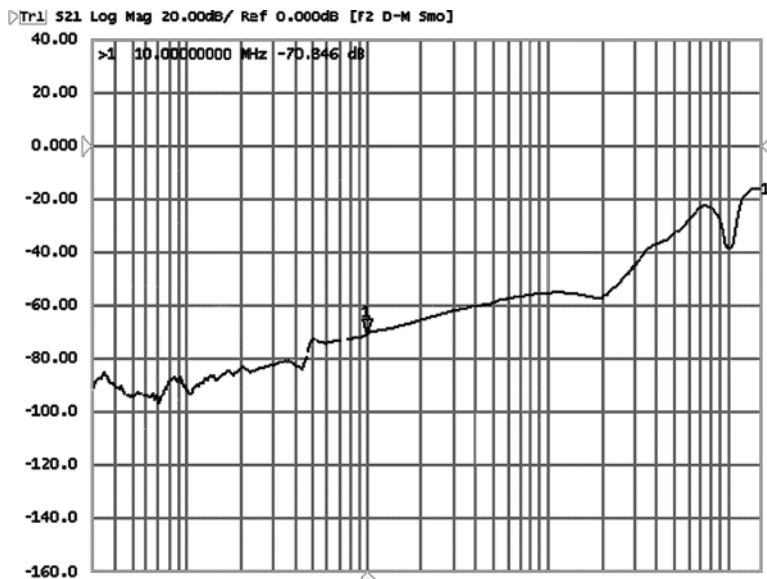

FIGURE 5. OFF Crosstalk vs. Frequency

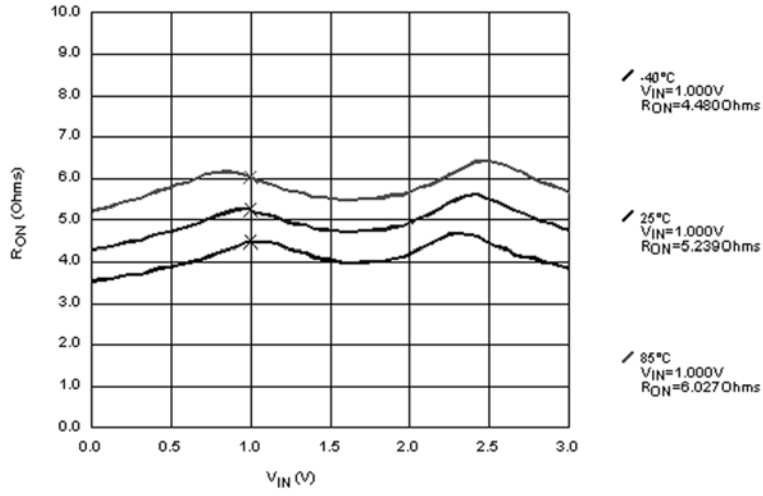

FIGURE 6. R_{ON} Switch On Resistance, I_{ON} = 13mA, V_{CC} = 3.0V

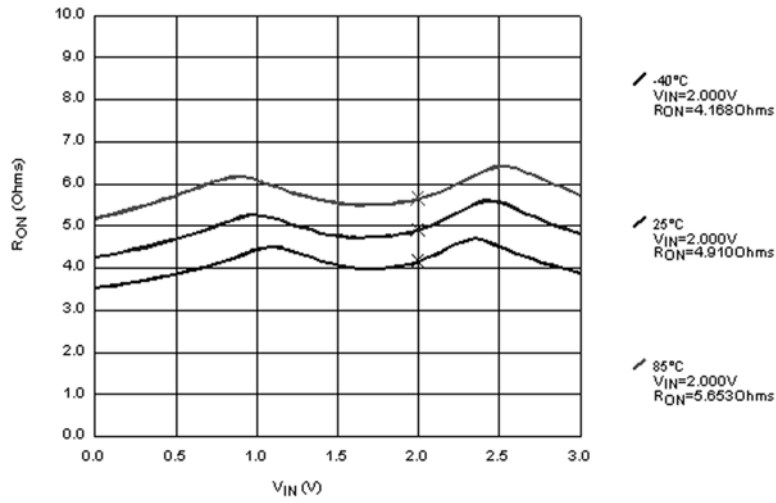
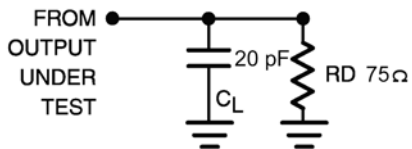

FIGURE 7. R_{ON} Switch On Resistance, I_{ON} = 26mA, V_{CC} = 3.0V

AC Loading and Waveforms



Note: Input driven by 50 Ω source terminated in 50 Ω

Note: C_L includes load and stray capacitance

Note: Input PRR = 1.0 MHz, $t_{IV} = 500$ ns

FIGURE 8. AC Test Circuit

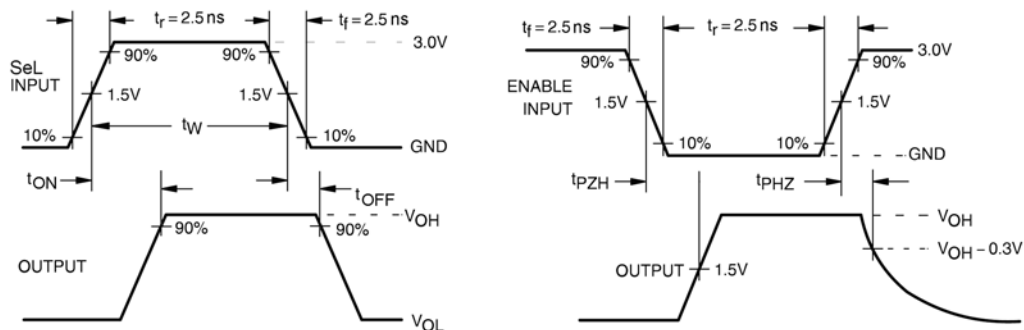

FIGURE 9. AC Waveforms

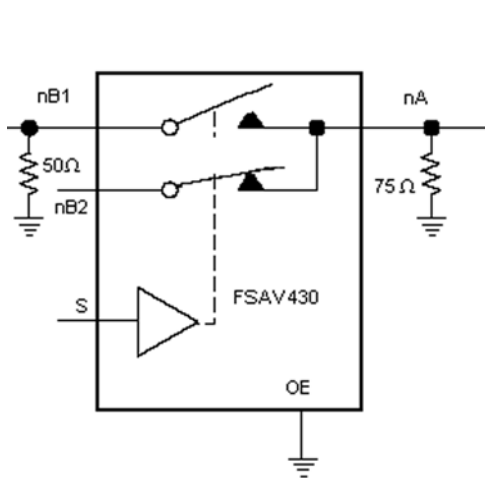

FIGURE 10. OFF Isolation Test

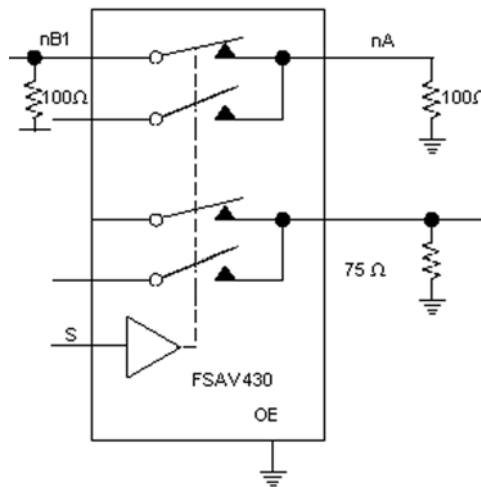

FIGURE 11. Crosstalk Test

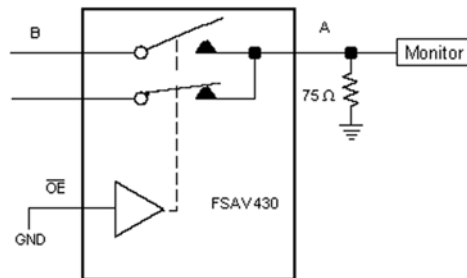

FIGURE 12. Bandwidth Test

Tape and Reel Specification

Tape Format for DQFN

Package Designator	Tape Section	Number Cavities	Cavity Status	Cover Tape Status
BQX	Leader (Start End)	125 (typ)	Empty	Sealed
	Carrier	2500/3000	Filled	Sealed
	Trailer (Hub End)	75 (typ)	Empty	Sealed

TAPE DIMENSIONS inches (millimeters)

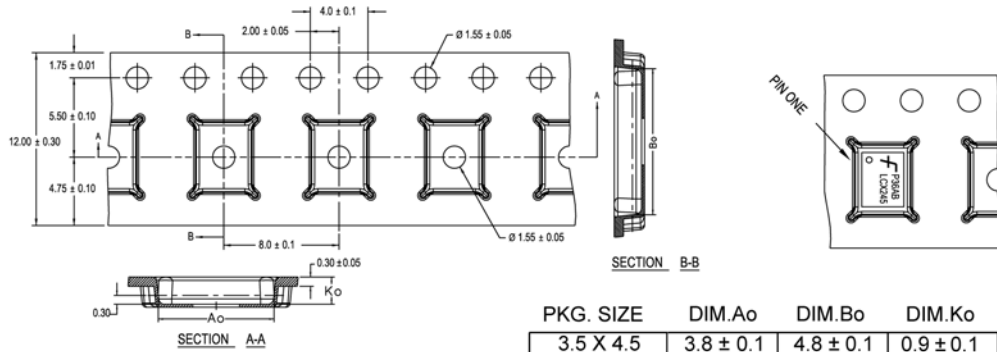

PKG. SIZE	DIM.Ao	DIM.Bo	DIM.Ko
3.5 X 4.5	3.8 ± 0.1	4.8 ± 0.1	0.9 ± 0.1
3.0 X 3.0	3.3 ± 0.1	3.3 ± 0.1	0.9 ± 0.1
2.5 X 4.5	2.8 ± 0.1	4.8 ± 0.1	0.9 ± 0.1
2.5 X 3.5	2.8 ± 0.1	3.8 ± 0.1	0.9 ± 0.1
2.5 X 3.0	2.8 ± 0.1	3.3 ± 0.1	0.9 ± 0.1
2.5 X 2.5	2.8 ± 0.1	2.8 ± 0.1	0.9 ± 0.1

DIMENSIONS ARE IN MILLIMETERS

NOTES: unless otherwise specified

1. Cumulative pitch for feeding holes and cavities (chip pockets) not to exceed 0.008[0.20] over 10 pitch span.
2. Smallest allowable bending radius.
3. Thru hole inside cavity is centered within cavity.
4. Tolerance is ±0.002[0.05] for these dimensions on all 12mm tapes.
5. Ao and Bo measured on a plane 0.120[0.30] above the bottom of the pocket.
6. Ko measured from a plane on the inside bottom of the pocket to the top surface of the carrier.
7. Pocket position relative to sprocket hole measured as true position of pocket. Not pocket hole.
8. Controlling dimension is millimeter. Dimension in inches rounded.

REEL DIMENSIONS inches (millimeters)

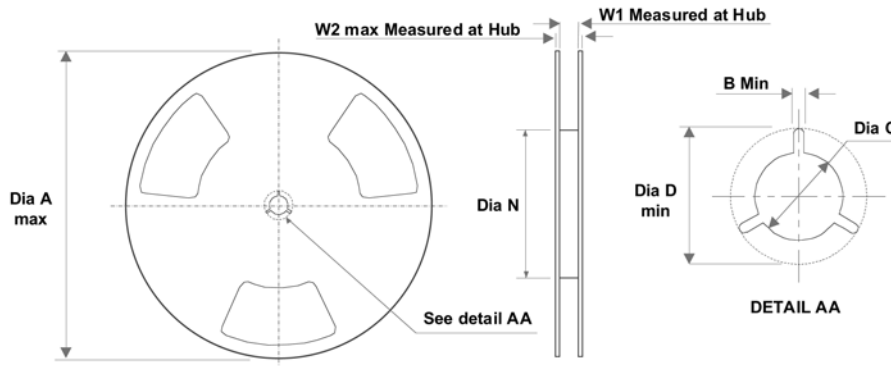

Tape Size	A	B	C	D	N	W1	W2
12 mm	13.0 (330)	0.059 (1.50)	0.512 (13.00)	0.795 (20.20)	7.008 (178)	0.488 (12.4)	0.724 (18.4)

Physical Dimensions inches (millimeters) unless otherwise noted

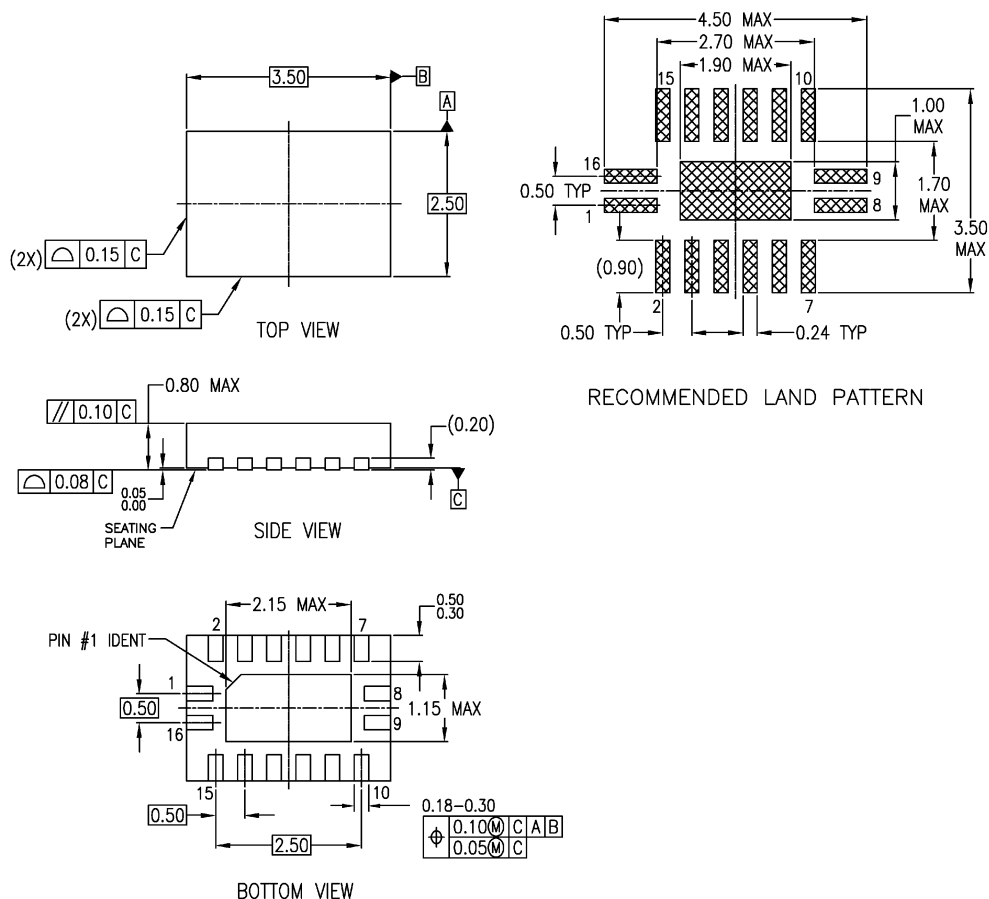

NOTES:

- A. CONFORMS TO JEDEC REGISTRATION MO-241, VARIATION AB
- B. DIMENSIONS ARE IN MILLIMETERS.
- C. DIMENSIONS AND TOLERANCES PER ASME Y14.5M, 1994

MLP016ErevA

Pb-Free 16-Terminal Depopulated Quad Very-Thin Flat Pack No Leads (DQFN), JEDEC MO-241, 2.5 x 3.5mm Package Number MLP016E

Physical Dimensions inches (millimeters) unless otherwise noted (Continued)

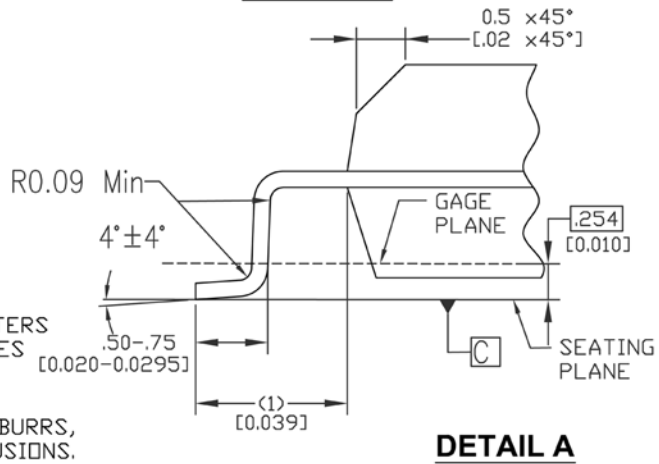
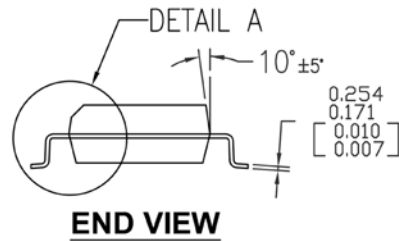
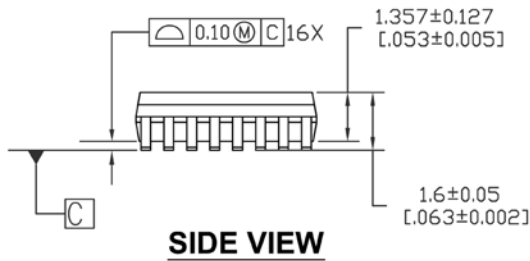
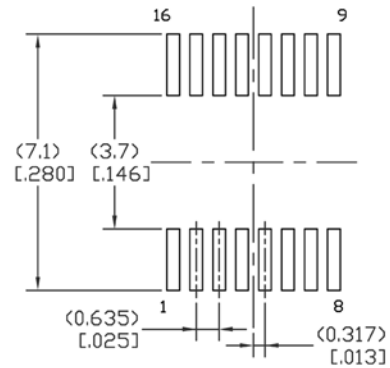
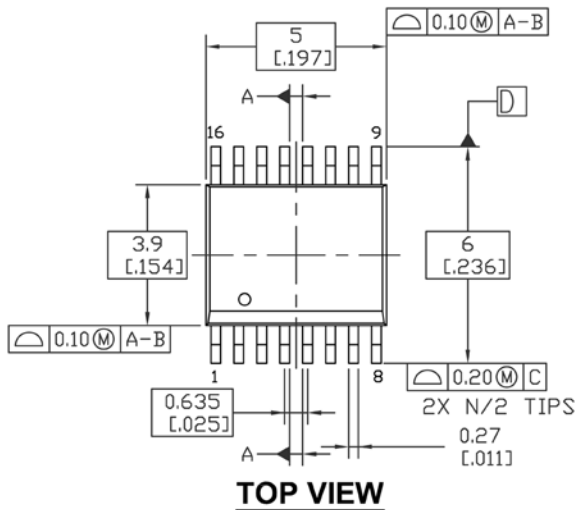

NOTES :

- A. THIS PACKAGE CONFORMS TO JEDEC MO-137 VARIATION AB
- B. PRIMARY DIMENSIONS IN MILLIMETERS
REFERENCE DIMENSIONS IN INCHES
- C. DRAWING CONFORMS TO ASME Y14.5M-1994
- D. DIMENSIONS ARE EXCLUSIVE OF BURRS, MOLD FLASH, AND TIE BAR EXTRUSIONS.

MQA16AREVB

**16-Lead Quarter Size Small Outline Package (QSOP), JEDEC MO-137, 0.150" Wide
Package Number MQA16A**

Physical Dimensions inches (millimeters) unless otherwise noted (Continued)

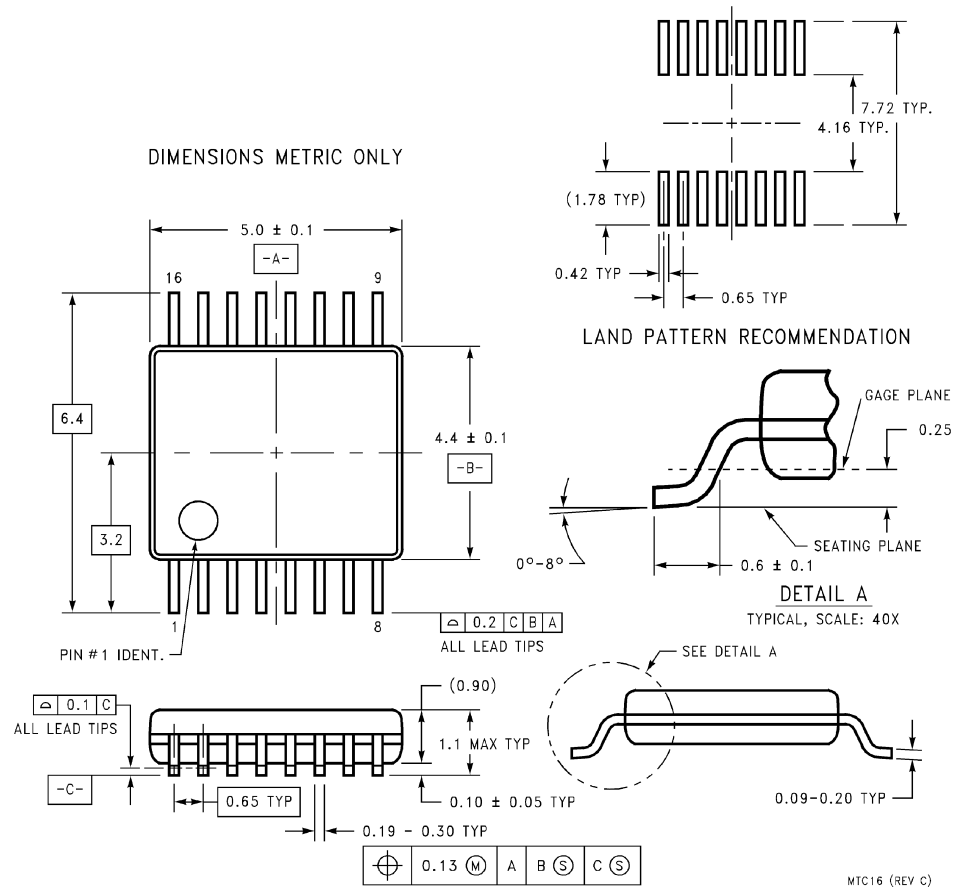

**16-Lead Thin Shrink Small Outline Package (TSSOP), JEDEC MO-153, 4.4mm Wide
Package Number MTC16**

Technology Description

The Fairchild Switch family derives from and embodies Fairchild's proven switch technology used for several years in its 74LVX3L384 (FST3384) bus switch product.

DISCLAIMER

FAIRCHILD SEMICONDUCTOR RESERVES THE RIGHT TO MAKE CHANGES WITHOUT FURTHER NOTICE TO ANY PRODUCTS HEREIN TO IMPROVE RELIABILITY, FUNCTION OR DESIGN. FAIRCHILD DOES NOT ASSUME ANY LIABILITY ARISING OUT OF THE APPLICATION OR USE OF ANY PRODUCT OR CIRCUIT DESCRIBED HEREIN; NEITHER DOES IT CONVEY ANY LICENSE UNDER ITS PATENT RIGHTS, NOR THE RIGHTS OF OTHERS.

LIFE SUPPORT POLICY

FAIRCHILD'S PRODUCTS ARE NOT AUTHORIZED FOR USE AS CRITICAL COMPONENTS IN LIFE SUPPORT DEVICES OR SYSTEMS WITHOUT THE EXPRESS WRITTEN APPROVAL OF FAIRCHILD SEMICONDUCTOR CORPORATION

As used herein:

1. Life support devices or systems are devices or systems which, (a) are intended for surgical implant into the body, or (b) support or sustain life, or (c) whose failure to perform when properly used in accordance with instructions for use

provided in the labeling, can be reasonably expected to result in significant injury to the user.

2. A critical component is any component of a life support device or system whose failure to perform can be reasonably expected to cause the failure of the life support device or system, or to affect its safety or effectiveness.

PRODUCT STATUS DEFINITIONS

Definition of terms

Datasheet Identification	Product Status	Definition
Advance Information	Formative or In Design	This datasheet contains the design specifications for product development. Specifications may change in any manner without notice.
Preliminary	First Production	This datasheet contains preliminary data, and supplementary data will be published at a later date. Fairchild Semiconductor reserves the right to make changes at any time without notice in order to improve design.
No Identification Needed	Full Production	This datasheet contains final specifications. Fairchild Semiconductor reserves the right to make changes at any time without notice in order to improve design.
Obsolete	Not In Production	This datasheet contains specifications on a product that has been discontinued by Fairchild Semiconductor. The datasheet is printed for reference information only.